

IP68 Fans from ebmpapst

Highest protection against harsh environments.

ebmpapst

The engineer's choice



About ebm-papst North America



Headquarters - Farmington, CT

- 250,000 square feet
- 275 employees
- Contract manufacturing
- Acoustic testing chamber
- Complete air testing lab on site
- ISO 9001 and ISO 14001 certifications
- Distribution centers in Farmington, CT and Toronto, Canada

ebm-papst is an innovator and market leader in fans, blowers, and motors with core competencies in motor technology, aerodynamics, and electronics. With over 15,000 products, we provide solutions to a wide range of markets including Air-conditioning and Ventilation, Appliance, Commercial Refrigeration, Heating, Industrial, Lighting, IT / Telecom, Medical, Transportation and more.

Support when and where you need it

Knowledgeable field sales professionals are close by for face-to-face meetings. Dedicated inside sales associates fulfill all of your ordering needs. To assist you with order management, our Customer Relations department provides automated services such as shipment notifications, reorder notifications, and invoicing.

Design and manufacturing

Beginning with the initial product concept, our application engineers work in tandem with customers to select the best air moving solution to suit specific goals and requirements. Once the prototype has been established, it can then be tested in our state-of-the-art airflow testing chambers to optimize performance. Each chamber has been designed to meet AMCA 210 and ISO 5801 requirements. In addition to our airflow testing capabilities, ebm-papst can conduct comparative sound, temperature, and velocity tests. The electrical engineering team can design everything from simple fan controllers for monitoring fan speed to complex controllers and power supplies, filtering, and specific communication protocols.

Logistics and inventory management programs

Our facilities feature over 90,000 square feet of climate-controlled warehousing, and utilize bar coding for real-time inventory management. Supply chain management programs such as Kanban, demand/pull, safety stock, consignment, and local warehousing can be customized to your needs.



Sustainability is the center of our GreenTech philosophy

Eco-friendliness and sustainability have always been at the core of our thoughts and actions. For decades, we have worked according to the simple but strict creed of our co-founder Gerhard Sturm: "Each new product we develop has to be better than the last one in terms of economy and ecology." GreenTech is the ultimate expression of our corporate philosophy.

The symbol of our commitment

Our company philosophy encompasses much more than designing new and more efficient fans and blowers; we put it into practice daily - in our offices and factories around the world! GreenTech symbolizes our continuous commitment, achievements, and passion to provide customers with the highest quality products using modern development and production methods, responsible business practices and initiatives that benefit the user as well as the environment.

GreenTech is eco-friendly production

Our GreenTech philosophy drives our product development, upholding the most stringent energy efficiency and environmental standards. Our production processes incorporate GreenTech practices including intelligent use of industrial waste heat and groundwater cooling, photovoltaics and our own cooling and ventilation technology. Our most modern plant consumes 91% less energy than required. From their origin to their recyclable packaging, our products contribute to the protection of the environment.

GreenTech is pro-active development

Even in the design phase, the materials and processes we use maximize the greatest possible eco-friendliness, energy balance and – wherever possible – recyclability. We work to continually improve the material components and performance of our products, as well as enhancing the airflow, decreasing noise characteristics and significantly reducing energy consumption.

Our customers profit from this every day

The heart of GreenTech is our EC technology. At the core of our energy-saving motors and fans, EC technology provides up to 90% efficiency, significantly extends service life and makes our products maintenance-free. These values pay off for the environment as well as offer cost-savings for the user! All ebm-papst products feature the greatest possible connection of economy and ecology.



IP68 Defined

Ingress Protection (IP) is a standard protection rating on electrical enclosures that defines the degree of protection provided against intrusion by solids (fingers, dust, etc.) and liquids. The importance of an IP68 rating on ebm-papst products is to ensure the highest level of protection of the electronics inside the enclosure against foreign objects and water, while also protecting the user against potentially harmful contact.

Ingress Protection at a glance

Ingress protection is the level of protection against the intrusion of solid objects, liquids, dust, and accidental contact with electrical enclosures inside a mechanical casing. This rating gives users a more detailed understanding of general terms such as waterproof or water-resistant.

The numerical digits represent conformity with the conditions outlined in the table below. For example, an electrical enclosure rated IP68 is completely protected against dust and can not be damaged or become unsafe during permanent immersion in water (to a depth greater than IPX7 which is to be defined between ebm-papst and the end user).

Applications and target markets

Environmentally protected cooling solutions are highly beneficial to applications within the Alternative Energy, Appliance, Commercial Refrigeration, Heating, IT/Telecom, LED/Lighting and Transportation markets.

IP68 protection may be available beyond what is listed in this brochure. Please contact our application engineers for more information at sales@us.ebmpapst.com

IPXX Defined

IP:	Ingress Protection
First Digit:	Rating of protection against solid objects
Second Digit:	Rating of protection against liquids



*IP20 protection - for indoor (clean/dry) applications where no additional protection for motor (electronics or windings) is required.



*IP68 protection - the motor (electronics and windings) are completely encapsulated

IP68 Defined

IP (Ingress Protection) Rating - Code Definition

Rating	Solid Protection (first digit)	Rating	Liquid Protection (second digit)
0	No protection	0	No protection
1	Protection against objects > 50mm (hands)	1	Protection against dripping water or condensation
2	Protection against objects > 12mm (fingers)	2	Protection against water spray 15° from vertical
3	Protection against objects > 2.5mm (tools/wires)	3	Protection against water spray 60° from vertical
4	Protection against objects > 1mm (small tools)	4	Protection against water spray from all directions.
5	Protection against dust, limited ingress	5	Protection against low pressure jets of water
6	Complete protection against dust	6	Protection against high pressure water jets and heavy seas
		7	Protection against the effects of immersion (6in- 3.3ft)
		8	Protection against permanent immersion

*Enlarged view of IP68 encapsulation area.

IP68
RATING

КВАДРАТ

DC axial fans

Series 600 NU 60 x 60 x 25 mm

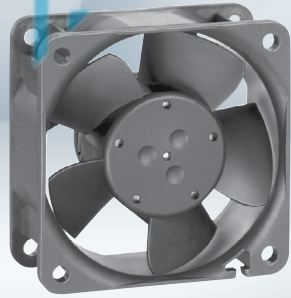

Highlights:

- Motor protection against reverse polarity and locking.
- Air exhaust over struts
- Connection via 310 mm strands AWG 22, TR 64, bared and tin-plated
- Ingress protection rating of IP68

Material: Housing: Fiberglass-reinforced PBT composite
Impeller: Fiberglass-reinforced PA composite

Direction of rotation: Clockwise, seen on rotor

IP68
RATING

КВАДРАТ

DC axial fans

Series 630 U 60 x 60 x 25 mm

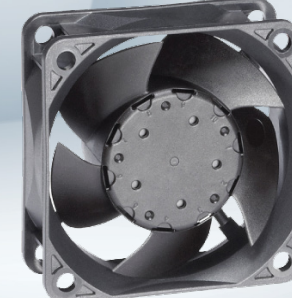

Highlights:

- Motor protection against reverse polarity and locking.
- Air exhaust over struts
- Connection via 310 mm strands AWG 22, TR 64, bared and tin-plated
- Ingress protection rating of IP68

Material: Housing: Fiberglass-reinforced PBT composite
Impeller: Fiberglass-reinforced PA composite

Direction of rotation: Clockwise, seen on rotor

Nominal Data

Type	Air flow CFM	Nominal voltage VDC	Voltage range VDC	Sound pressure level dB(A)	Sound power level Bel(A)	Ball bearings	Power input Watts	Speed RPM	Temperature range °C	Mass g	Ingress Protection Rating	UL Approval	Curves
612 NHU-181	25.3	12	8...15	37	5.3	Yes	1.8	5600	-20...70	66	IP68	Yes	1
614 NHU	25.3	24	18...26	37	5.3	Yes	2.1	5600	-20...70	66	IP68	Yes	1
614 NHHU-286	33.0	24	18...26	41	5.7	Yes	2.9	6850	-20...70	66	IP68	Yes	2

Nominal Data

Type	Air flow CFM	Nominal voltage VDC	Voltage range VDC	Sound pressure level dB(A)	Sound power level Bel(A)	Ball bearings	Power input Watts	Speed RPM	Temperature range °C	Mass g	Ingress Protection Rating	UL Approval	Curves
632 NU	23.5	12	6...15	34	5.1	Yes	1.8	5900	-20...70	70	IP68	Yes	1
634 NU-004*	23.5	24	12...30	34	5.1	Yes	1.6	5900	-20...70	70	IP68	Yes	1
632/2HPU	25.9	12	11...13	35	5.4	Yes	1.5	6300	-20...70	70	IP68	Yes	2
634 HHU	34.1	24	18...28	44	6.1	Yes	3.2	8500	-20...70	70	IP68	Yes	3
634/2HHPU	34.1	24	18...28	44	6.1	Yes	3.2	8500	-20...70	70	IP68	Yes	3

Curves

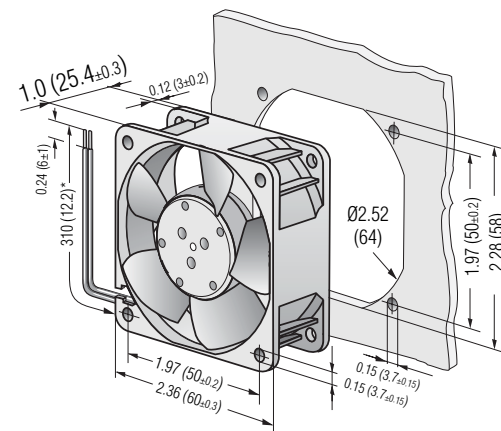
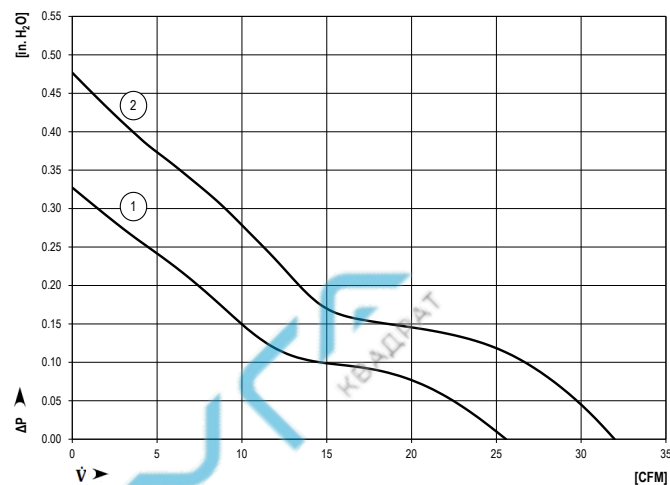

Curves

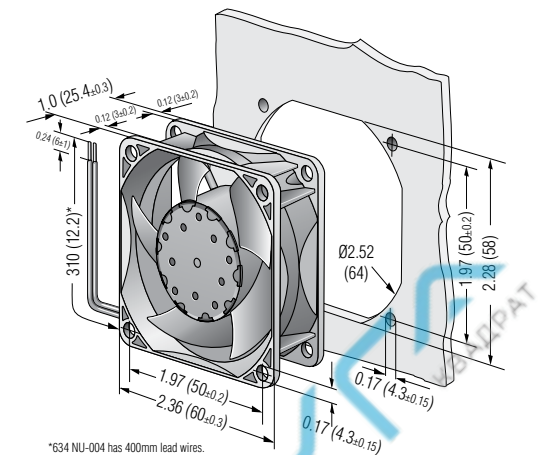
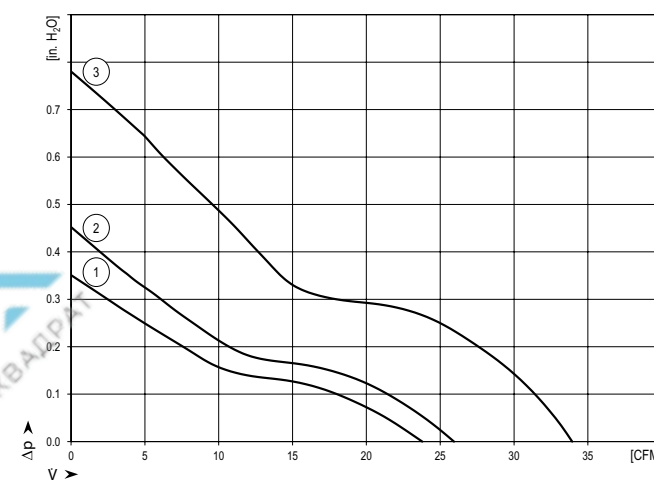

*634 NU-004 has 400mm lead wires.

IP68
RATING

КВАДРАТ

DC axial fans

Series 8400 NU 80 x 80 x 25 mm

Highlights:

- Motor protection against reverse polarity and locking.
- Air exhaust over struts
- Connection via 310 mm strands AWG 24, TR 64, bared and tin-plated
- Ingress protection rating of IP68

Material: Housing: Fiberglass-reinforced PBT composite
Impeller: Fiberglass-reinforced PA composite

Direction of rotation: Counterclockwise, seen on rotor



IP68
RATING

КВАДРАТ

DC axial fans

Series 8300 U 80 x 80 x 32 mm

Highlights:

- Motor protection against reverse polarity and locking.
- Air exhaust over struts
- Connection via 310 mm strands AWG 22, TR 64, bared and tin-plated
- Ingress protection rating of IP68

Material: Housing: Fiberglass-reinforced PBT composite
Impeller: Fiberglass-reinforced PA composite

Direction of rotation: Clockwise, seen on rotor

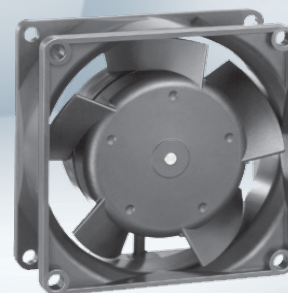

Nominal Data

Type	Air flow CFM	Nominal voltage VDC	Voltage range VDC	Sound pressure level dB(A)	Sound power level Bel(A)	Ball bearings	Power input Watts	Speed RPM	Temperature range °C	Mass g	Ingress Protection Rating	UL Approval	Curves
8414 NLU	19.4	24	18...28	17	3.7	Yes	0.8	1500	-20...70	95	IP68	Yes	1
8414 NMU	34.1	24	18...28	27	4.4	Yes	1.4	2600	-20...70	95	IP68	Yes	2
8412 NU	40.6	12	8...15	32	4.7	Yes	1.7	3100	-20...70	95	IP68	Yes	3
8414 NHU	46.5	24	18...26	37	5.0	Yes	2.4	3600	-20...65	95	IP68	Yes	4

Nominal Data

Type	Air flow CFM	Nominal voltage VDC	Voltage range VDC	Sound pressure level dB(A)	Sound power level Bel(A)	Ball bearings	Power input Watts	Speed RPM	Temperature range °C	Mass g	Ingress Protection Rating	UL Approval	Curves
8314 U	31.8	24	12...31.5	36	5.2	Yes	2.7	3300	-20...75	210	IP68	Yes	1
8312 HLU	39.4	12	6...15	43	5.8	Yes	4.0	4200	-20...75	210	IP68	Yes	2
8314 HU	47.1	24	12...28	48	6.2	Yes	6.2	5000	-20...65	210	IP68	Yes	3

Curves

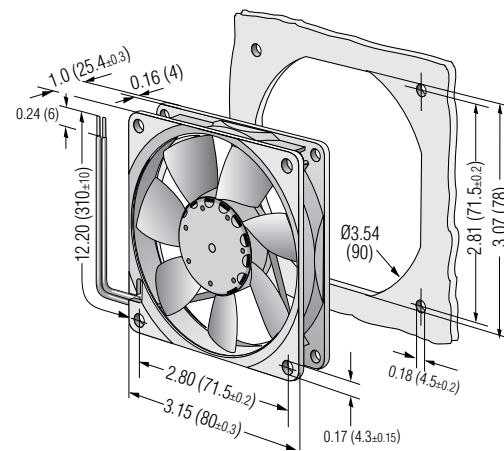
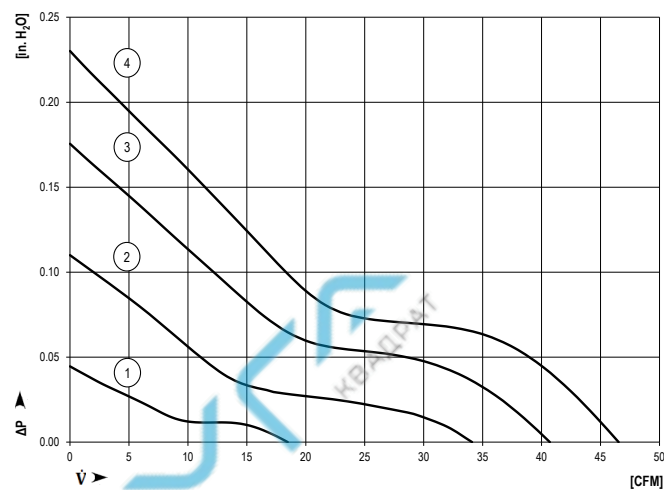

Curves

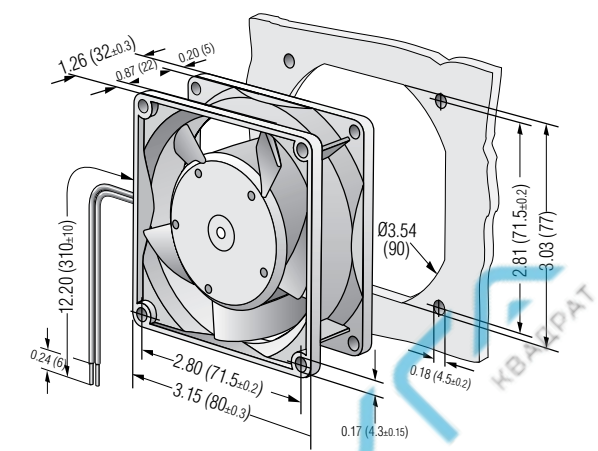
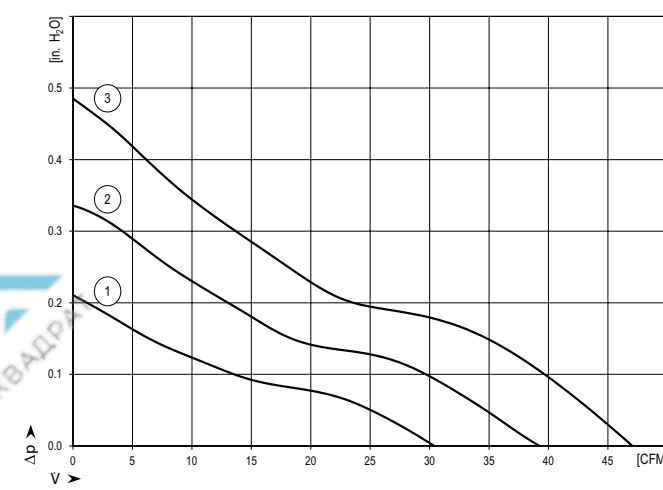

IP68
RATING

КВАДРАТ

DC axial fans

Series 3300 NU 92 x 92 x 32 mm

Highlights:

- Motor protection against reverse polarity and locking.
- Air exhaust over struts
- Connection via 310 mm strands AWG 22, TR 64, bared and tin-plated
- Ingress protection rating of IP68

Material: Housing: Fiberglass-reinforced PBT composite
Impeller: Fiberglass-reinforced PA composite

Direction of rotation: Clockwise, seen on rotor



IP68
RATING

КВАДРАТ

DC axial fans

Series 3400 NU 92 x 92 x 25 mm

Highlights:

- Motor protection against reverse polarity and locking.
- Air exhaust over struts
- Connection via 310 mm strands AWG 24, TR 64, bared and tin-plated
- Ingress protection rating of IP68

Material: Housing: Fiberglass-reinforced PBT composite
Impeller: Fiberglass-reinforced PA composite

Direction of rotation: Counterclockwise, seen on rotor



Nominal Data

Type	Air flow CFM	Nominal voltage VDC	Voltage range VDC	Sound pressure level dB(A)	Sound power level Bel(A)	Ball bearings	Power input Watts	Speed RPM	Temperature range °C	Mass g	Ingress Protection Rating	UL Approval	Curves
3312 NNU	47.1	12	6...15	35	4.7	Yes	1.8	2650	-20...75	190	IP68	Yes	1
3312 NHHU	63.0	12	6...15	42	5.4	Yes	3.4	3450	-20...75	190	IP68	Yes	1
3314 NNU	47.1	24	18...28	35	4.7	Yes	1.8	2650	-20...75	190	IP68	Yes	1
3314 NHHU	63.0	24	18...28	42	5.4	Yes	3.5	3450	-20...75	190	IP68	Yes	2

Nominal Data

Type	Air flow CFM	Nominal voltage VDC	Voltage range VDC	Sound pressure level dB(A)	Sound power level Bel(A)	Ball bearings	Power input Watts	Speed RPM	Temperature range °C	Mass g	Ingress Protection Rating	UL Approval	Curves
3414 NMU-603	42.4	24	18...28	28	4.3	Yes	1.4	2300	-20...70	100	IP68	Yes	1
3414 NHU	55.3	24	18...26	36	5.0	Yes	2.3	3000	-20...70	106	IP68	Yes	2

Curves

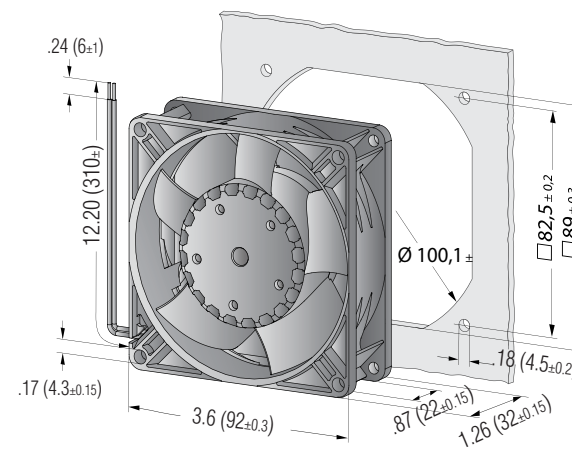
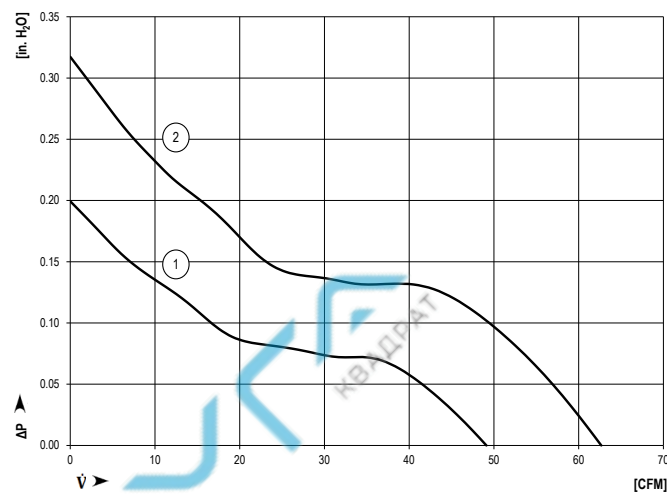

Curves

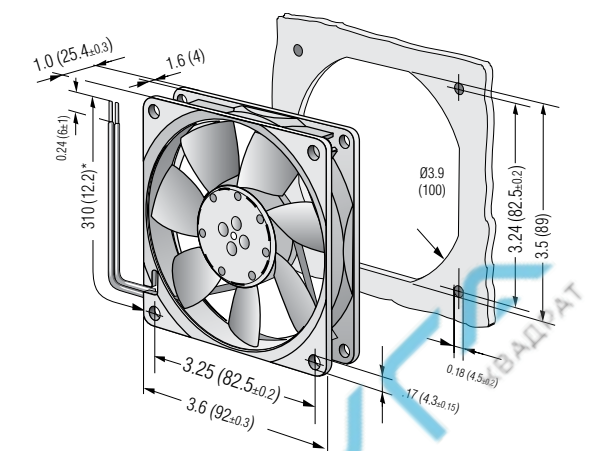
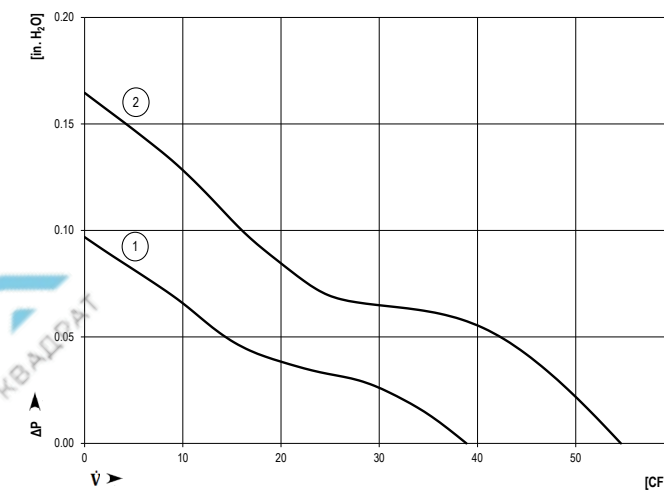

IP68
RATING

КВАДРАТ

DC axial fans

Series 3200 JU 92 x 92 x 38 mm



Highlights:

- Motor protection against reverse polarity and locking.
- Air exhaust over struts
- Connection via 310 mm strands AWG 24, TR 64, bared and tin-plated
- Ingress protection rating of IP68

Material: Housing: Fiberglass-reinforced PBT composite
Impeller: Fiberglass-reinforced PA composite

Direction of rotation: Clockwise, seen on rotor

Nominal Data

Type	Air flow CFM	Nominal voltage VDC	Voltage range VDC	Sound pressure level dB(A)	Sound power level Bel(A)	Ball bearings	Power input Watts	Speed RPM	Temperature range °C	Mass g	Ingress Protection Rating	UL Approval	Curves
3212J/2NU-343	76.5	12	7...13.8	51	6.0	Yes	8.1	6000	-20...60	240	IP68	Yes	1

Curves

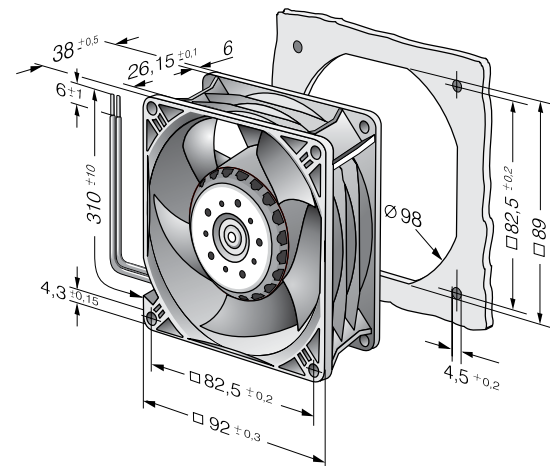
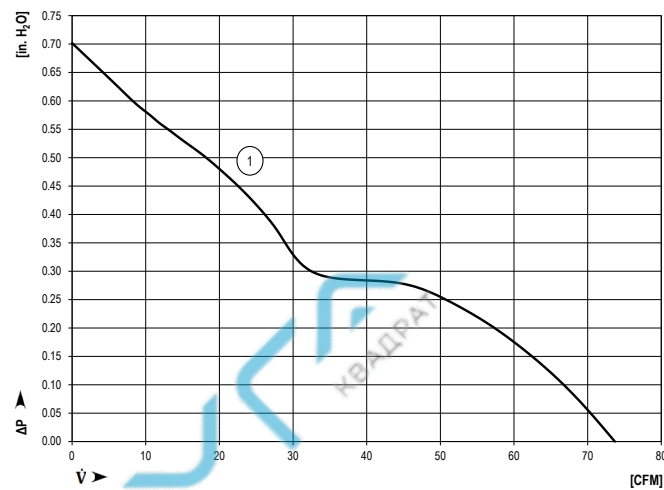

IP68
RATING

КВАДРАТ

DC axial fans

Series 3250 JU 92 x 92 x 38 mm



Highlights:

- Motor protection against reverse polarity and locking.
- Air exhaust over struts
- Connection via 310 mm strands AWG 24, TR 64, bared and tin-plated
- Ingress protection rating of IP68

Material: Housing: Fiberglass-reinforced PBT composite
Impeller: Fiberglass-reinforced PA composite

Direction of rotation: Clockwise, seen on rotor

Nominal Data

Type	Air flow CFM	Nominal voltage VDC	Voltage range VDC	Sound pressure level dB(A)	Sound power level Bel(A)	Ball bearings	Power input Watts	Speed RPM	Temperature range °C	Mass g	Ingress Protection Rating	UL Approval	Curves
3252 J/2H3PU	158.0	12	7...13.2	64	7.6	Yes	35.0	7450	-20...70	240	IP68	Yes	3
3254 J/2HPU	85.0	24	14...26.4	46	5.8	Yes	7.0	4100	-20...70	240	IP68	Yes	1
3258 J/2HPU	85.0	48	36...56.0	46	5.8	Yes	7.0	4100	-20...70	240	IP68	Yes	1
3258 J/2HHPU	138.0	48	36...56.0	59	7.0	Yes	24.3	6650	-20...70	240	IP68	Yes	2
3258 J/2H3PU	158.0	48	36...56.0	64	7.6	Yes	33.6	7450	-20...70	240	IP68	Yes	3

Curves

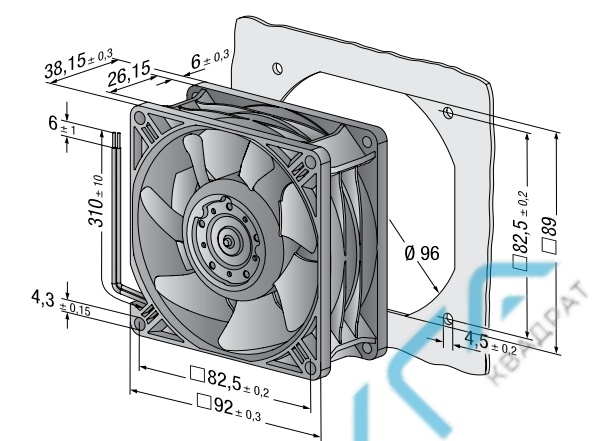
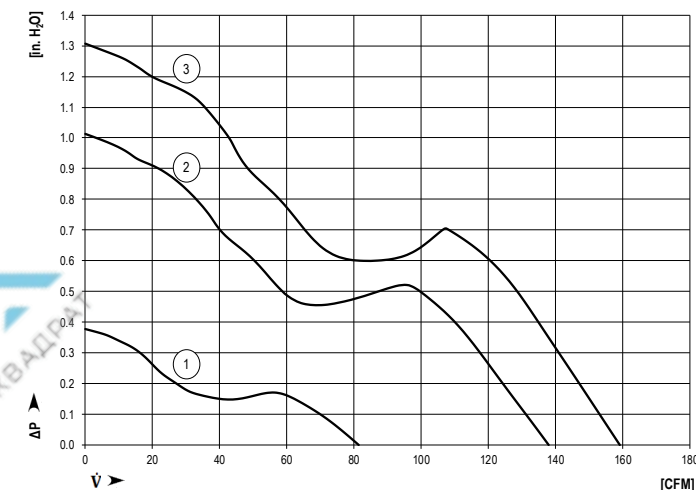

IP68
RATING

КВАДРАТ

DC axial fans

Series 4300 NU 119 x 119 x 32 mm



Highlights:

- Motor protection against reverse polarity and locking.
- Air exhaust over struts
- Connection via 310 mm strands AWG 22, TR 64, bared and tin-plated
- Ingress protection rating of IP68

Material: Housing: Fiberglass-reinforced PBT composite
Impeller: Fiberglass-reinforced PA composite

Direction of rotation: Clockwise, seen on rotor

IP68
RATING

КВАДРАТ

DC axial fans

Series 4100 NU 119 x 119 x 38 mm



Highlights:

- Motor protection against reverse polarity and locking.
- Air intake over struts
- Connection via 310 mm strands AWG 22, TR 64, bared and tin-plated
- Ingress protection rating of IP68

Material: Housing: Die-cast aluminum
Impeller: Fiberglass-reinforced PA composite

Direction of rotation: Clockwise, seen on rotor

Nominal Data

Type	Air flow CFM	Nominal voltage VDC	Voltage range VDC	Sound pressure level dB(A)	Sound power level Bel(A)	Ball bearings	Power input Watts	Speed RPM	Temperature range °C	Mass g	Ingress Protection Rating	UL Approval	Curves
4312 NNU	112	12	6...15	41	5.5	Yes	4.0	2700	-20...75	250	IP68	Yes	1
4314 NNU	112	24	12...28	41	5.5	Yes	4.0	2700	-20...75	250	IP68	Yes	1

Nominal Data

Type	Air flow CFM	Nominal voltage VDC	Voltage range VDC	Sound pressure level dB(A)	Sound power level Bel(A)	Ball bearings	Power input Watts	Speed RPM	Temperature range °C	Mass g	Ingress Protection Rating	UL Approval	Curves
4112 N/2HU	134.0	12	8...14	57.0	6.5	Yes	11.0	4400	-20...55	400	IP68	Yes	2
4114 NXU**	99.0	24	12...29	48.5	5.7	Yes	5.6	3200	-20...75	400	IP68	Yes	1
4114 NU	99.0	24	12...29	48.5	5.7	Yes	5.6	3200	-20...75	400	IP68	Yes	1
4114 NHU-295	134.0	24	16...30	57.0	6.5	Yes	11.0	4400	-20...55	400	IP68	Yes	2
4114 N/2HU-272*	134.0	24	12...25	57.0	6.5	Yes	11.0	4400	-20...55	400	IP68	Yes	2
4114 NXHHU**	153.0	24	12...28	60.0	7.0	Yes	13.6	4900	-20...55	400	IP68	Yes	3
4114 N/2H6PU	256.0	24	16...30	73.0	8.1	Yes	65.0	8400	-20...65	390	IP68	Yes	5
4114 N/2H6AU	256.0	24	16...30	73.0	8.1	Yes	65.0	8400	-20...65	390	IP68	Yes	5
4118 NHU-294	134.0	48	36...56	57.0	6.5	Yes	11.0	4400	-20...55	400	IP68	Yes	2
4118 N/2H4PU	206.0	48	36...60	67.0	7.0	Yes	34.0	6800	-20...65	400	IP68	Yes	4

Curves

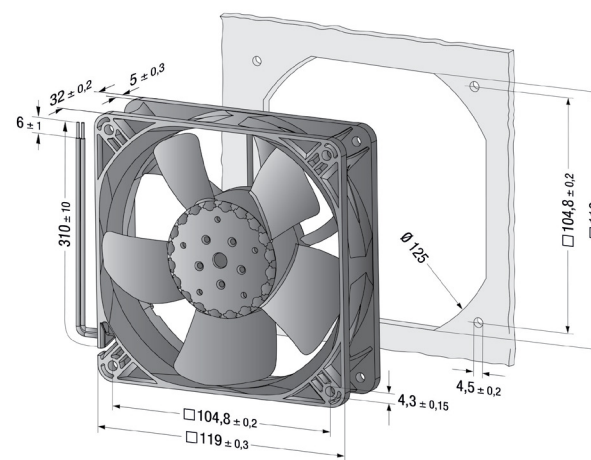
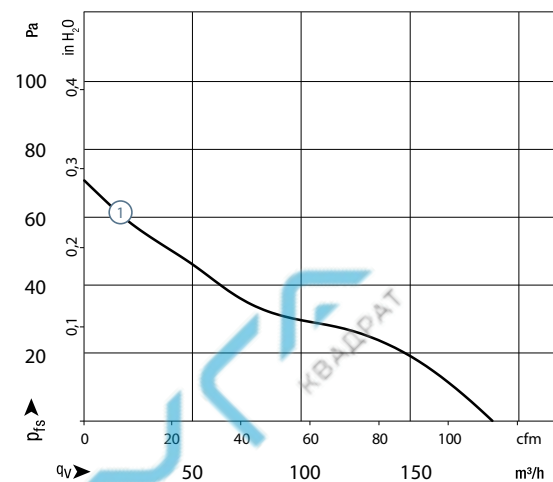

Curves

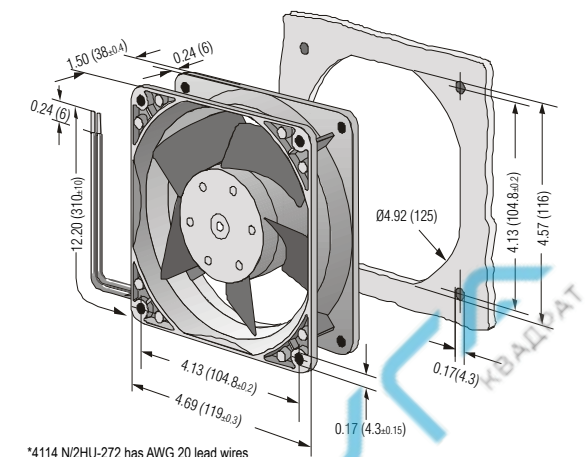
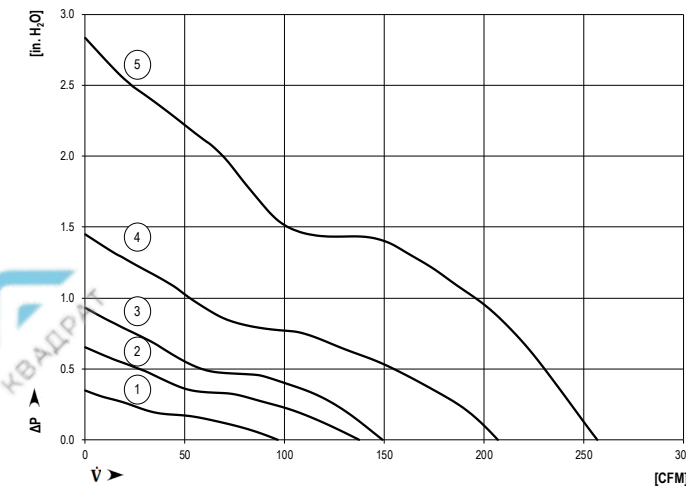

*4114 N/2HU-272 has AWG 20 lead wires

**Mounting hole diameter is 0.146 (3.7±0.15) on the 4114NX versions

IP68
RATING

КВАДРАТ

DC axial fans

Series DV 5200 U 127 x 127 x 38 mm



Highlights:

- Motor protection against reverse polarity and locking.
- Air exhaust over struts
- Connection via 310 mm strands AWG 22, TR 64, bared and tin-plated
- Ingress protection rating of IP68

Material: Housing: Die-cast aluminum
Impeller: Fiberglass-reinforced PA composite

Direction of rotation: Counterclockwise, seen on rotor

IP68
RATING

КВАДРАТ

DC axial fans

Series 6200 NU Ø172 x 51 mm



Highlights:

- Motor protection against reverse polarity and locking.
- Air exhaust over struts
- Connection via leads 310 mm AWG 22, TR 64, bared and tin-plated
- Ingress protection rating of IP68

Material: Housing: Die-cast aluminum
Impeller: Fiberglass-reinforced PA composite

Direction of rotation: Counterclockwise, seen on rotor

Nominal Data

Type	Air flow CFM	Nominal voltage VDC	Voltage range VDC	Sound pressure level dB(A)	Sound power level Bel(A)	Ball bearings	Power input Watts	Speed RPM	Temperature range °C	Mass g	Ingress Protection Rating	UL Approval	Curves
DV 5214 NU	158.9	24	18...26	56	6.4	Yes	19.8	4930	-20...65	560	IP68	Yes	1
DV 5214/2NU-807	158.9	24	16...30	56	6.0	Yes	20.1	5000	-20...65	560	IP68	Yes	1

Nominal Data

Type	Air flow CFM	Nominal voltage VDC	Voltage range VDC	Sound pressure level dB(A)	Sound power level Bel(A)	Ball bearings	Power input Watts	Speed RPM	Temperature range °C	Mass g	Ingress Protection Rating	UL Approval	Curves
6224 NMU	206.0	24	12...32	50	5.7	Yes	11.6	2950	-20...60	840	IP68	Yes	1
6224 NU	241.3	24	12...28	55	6.1	Yes	15.6	3400	-20...72	840	IP68	Yes	2

Curves

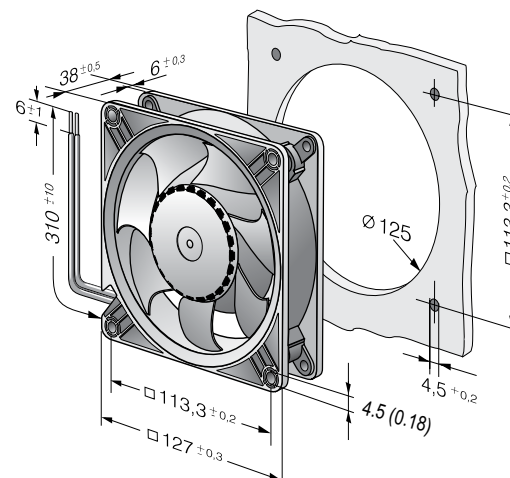
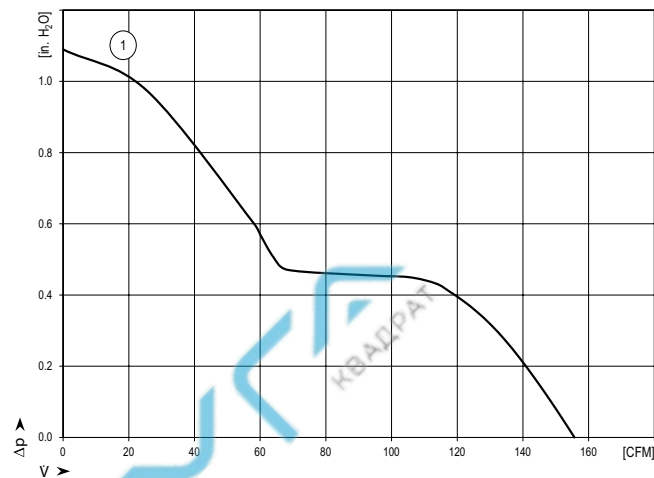

Curves

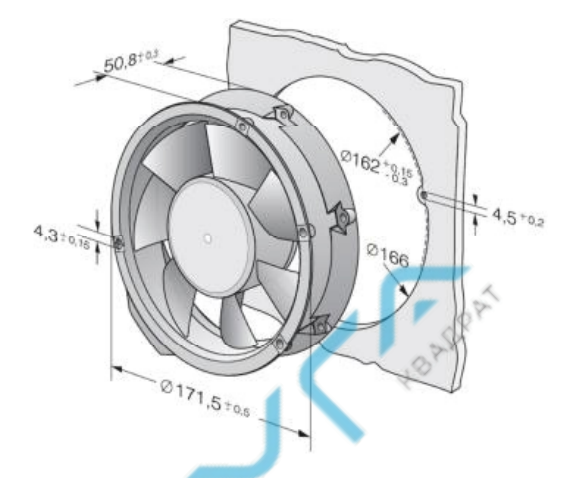
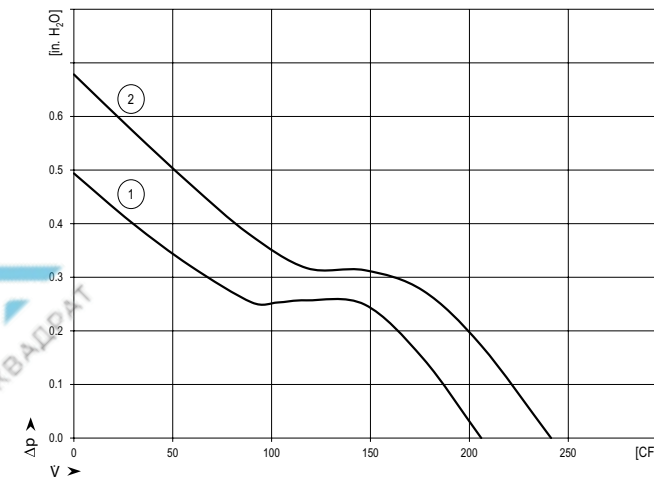

IP68
RATING

КВАДРАТ

DC axial fans

Series 6300 U Ø172 x 51 mm



Highlights:

- Motor protection against reverse polarity and locking.
- Air exhaust over struts
- Connection via leads 365 mm AWG 22, TR 64, bared and tin-plated
- Ingress protection rating of IP68

Material: Housing: Die-cast aluminum
Impeller: Fiberglass-reinforced PA composite

Direction of rotation: Counterclockwise, seen on rotor

IP68
RATING

КВАДРАТ

DC axial fans

Series 6400 U 172 x 150 x 51 mm



Highlights:

- Motor protection against reverse polarity and locking.
- Air exhaust over struts
- Connection via leads 310 mm AWG 22, TR 64, bared and tin-plated
- Ingress protection rating of IP68

Material: Housing: Die-cast aluminum
Impeller: Fiberglass-reinforced PA composite

Direction of rotation: Counterclockwise, seen on rotor

Nominal Data

Type	Air flow CFM	Nominal voltage VDC	Voltage range VDC	Sound pressure level dB(A)	Sound power level Bel(A)	Ball bearings	Power input Watts	Speed RPM	Temperature range °C	Mass g	Ingress Protection Rating	UL Approval	Curves
6314 HU-227	321.0	24	16...30	58	6.9	Yes	31	5000	-20...50	910	IP68	Yes	1
6318/2 HPU-216	321.0	48	36...60	58	6.9	Yes	31	5000	-20...65	910	IP68	Yes	1
6318 N/2H3PU	403.0	48	36...72	-	7.5	Yes	53	5000	-20...70	935	IP68	Yes	2

Nominal Data

Type	Air flow CFM	Nominal voltage VDC	Voltage range VDC	Sound pressure level dB(A)	Sound power level Bel(A)	Ball bearings	Power input Watts	Speed RPM	Temperature range °C	Mass g	Ingress Protection Rating	UL Approval	Curves
6424/2U	241.3	24	12...28	57	6.4	Yes	17	3400	-20...67	870	IP68	Yes	2
6424 MU	206.0	24	12...32	52	6.0	Yes	12	2850	-20...72	760	IP68	Yes	1
6448 U	241.3	48	28...60	57	6.4	Yes	17	3400	-20...67	870	IP68	Yes	2
6424 HU	283.0	24	12...28	63	7.1	Yes	26	4000	-20...55	870	IP68	Yes	3

Curves

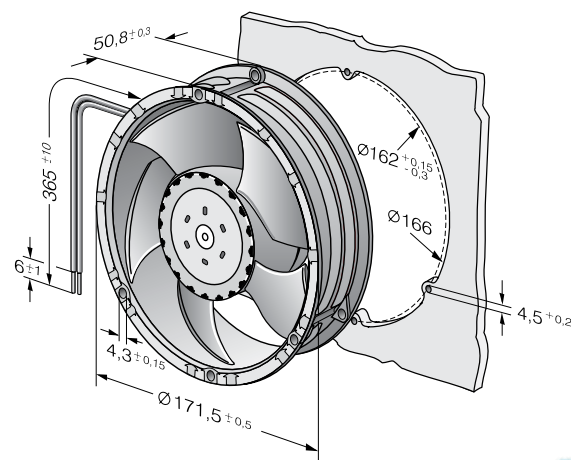
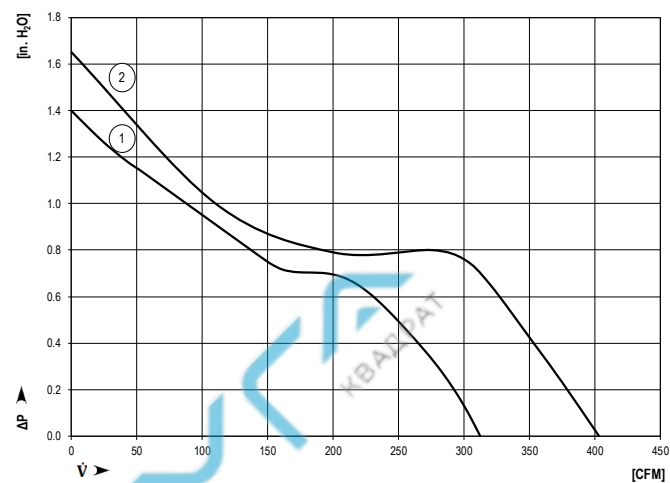

Curves

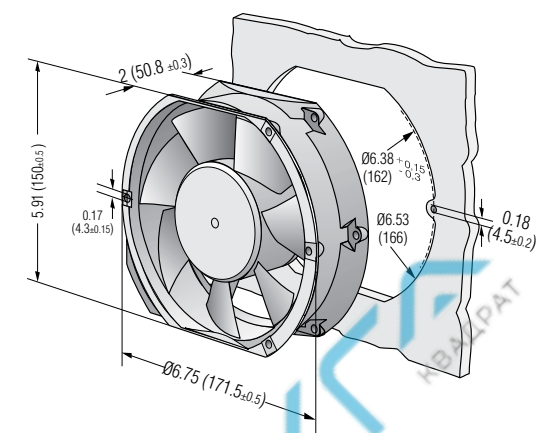
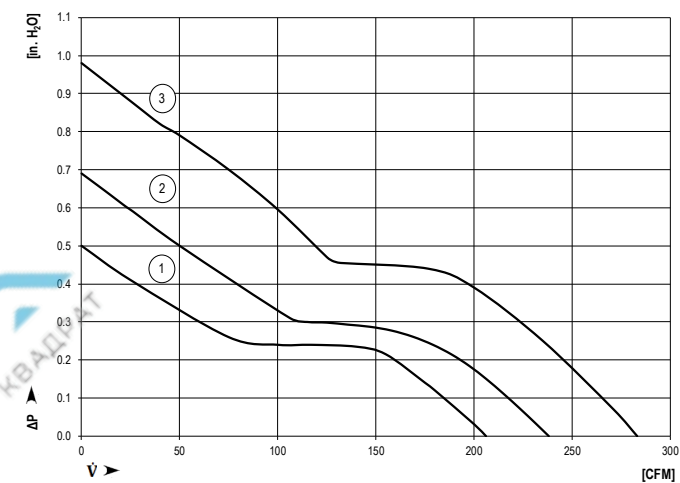

IP68
RATING

КВАДРАТ

DC centrifugal fans

Series RG 160 NU 220 x 220 x 56 mm



Highlights:

- Backward curved impeller
- Motor protection against reverse polarity and locking.
- Direction of air flow: axial air intake, centrifugal air exhaust
- Connection via single strands AWG 22, TR 64, bared and tin-plated
- Ingress protection rating of IP68

Material: Impeller: Fiberglass-reinforced composite
Housing: Fiberglass-reinforced composite scroll
Baseplate: Steel

Direction of rotation: Counterclockwise, seen on rotor

IP68
RATING

КВАДРАТ

DC centrifugal fans

Series RG 160 NTDU 220 x 220 x 56 mm

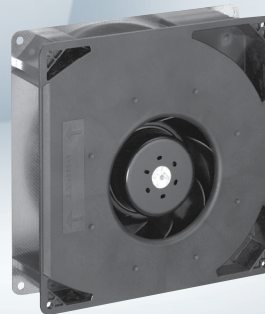

Highlights:

- Backward curved impeller
- Motor protection against reverse polarity and locking.
- Direction of air flow: axial air intake, centrifugal air exhaust
- Connection via single strands AWG 22, TR 64, bared and tin-plated
- Ingress protection rating of IP68

Material: Impeller: Fiberglass-reinforced composite
Housing: Fiberglass-reinforced composite scroll
Baseplate: Steel

Direction of rotation: Counterclockwise, seen on rotor

Nominal Data

Type	Air flow CFM	Nominal voltage VDC	Voltage range VDC	Sound pressure level dB(A)	Sound power level Bel(A)	Ball bearings	Power input Watts	Speed RPM	Temperature range °C	Mass g	Ingress Protection Rating	UL Approval	Curves
RG 160-28/14NU	123.0	24	12...28	-	6.6	Yes	20	2850	-20...70	1400	IP68	Yes	1
RG 160-28/18NU	123.0	48	28...60	-	6.6	Yes	20	2850	-20...70	1400	IP68	Yes	1

Nominal Data

Type	Air flow CFM	Nominal voltage VDC	Voltage range VDC	Sound pressure level dB(A)	Sound power level Bel(A)	Ball bearings	Power input Watts	Speed RPM	Temperature range °C	Mass g	Ingress Protection Rating	UL Approval	Curves
RG 160-28/18N/2TDPU-331	182.5	48	38...57	-	7.5	Yes	57.6	4270	-20...75	1400	IP68	Yes	1

Curves

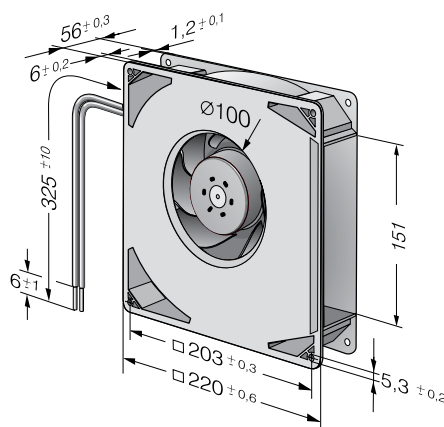
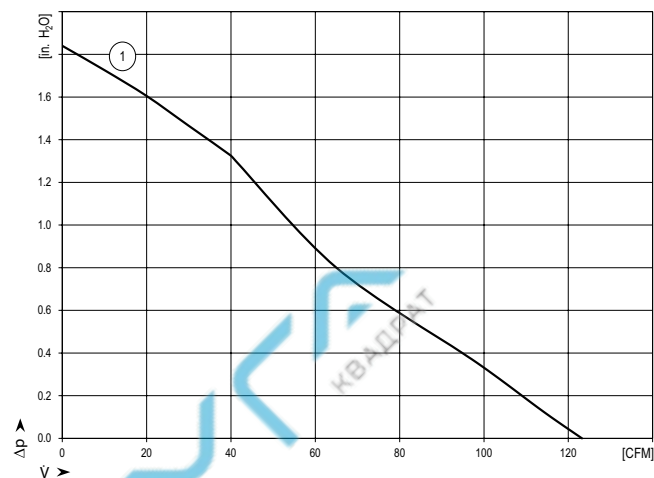

Curves

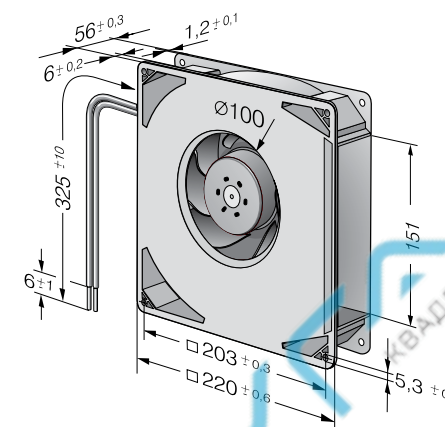
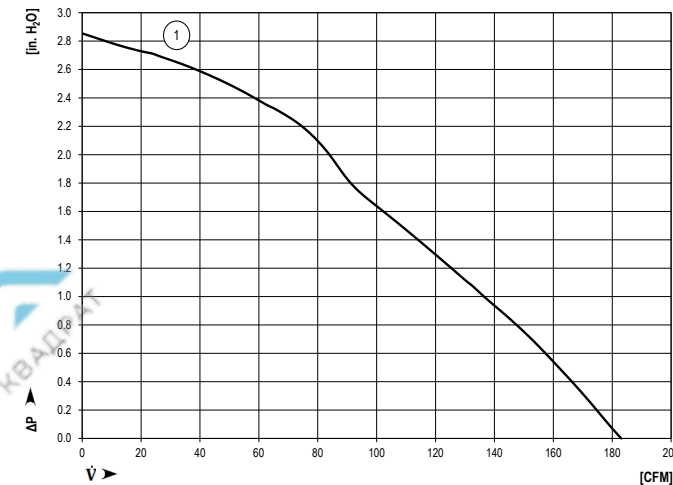

IP68
RATING

КВАДРАТ

DC centrifugal fans

Series RER 160 NTDU Ø165 x 51 mm



Highlights:

- Backward curved impeller
- Motor protection against reverse polarity and locking
- Direction of air flow: axial air intake, centrifugal air exhaust
- Connection via single strands AWG 22, TR 64, bared and tin-plated
- Ingress protection rating of IP68

Material: Impeller: Fiberglass-reinforced composite

Direction of rotation: Counterclockwise, seen on rotor

IP68
RATING

КВАДРАТ

DC centrifugal fans

Series RER 133 TDU Ø133 x 91 mm



Highlights:

- Backward curved impeller with 3-phase efficient motor
- Motor protection against reverse polarity and locking
- Direction of air flow: axial air intake, centrifugal air exhaust
- Connection via single strands AWG 22, TR 64, bared and tin-plated
- Ingress protection rating of IP68

Material: Impeller: Fiberglass-reinforced composite

Direction of rotation: Clockwise, seen on rotor

Nominal Data

Type	Air flow CFM	Nominal voltage VDC	Voltage range VDC	Sound pressure level dB(A)	Sound power level Bel(A)	Ball bearings	Power input Watts	Speed RPM	Temperature range °C	Mass g	Ingress Protection Rating	UL Approval	Curves
RER 160-28/18NTDAU	217.0	48	38...57	-	7.4	Yes	51	4200	-20...60	700	IP68	Yes	1

Nominal Data

Type	Air flow CFM	Nominal voltage VDC	Voltage range VDC	Sound pressure level dB(A)	Sound power level Bel(A)	Ball bearings	Power input Watts	Speed RPM	Temperature range °C	Mass g	Ingress Protection Rating	UL Approval	Curves
RER 133-41/18/2TDLOU	211.9	48	36...57	-	6.9	Yes	30.1	4000	-20...70	740	IP68	Yes	1

Curves

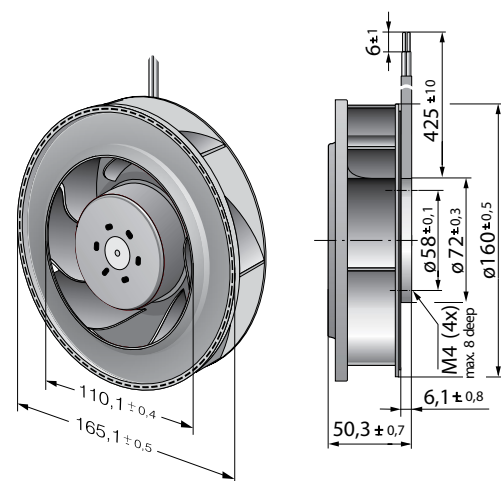
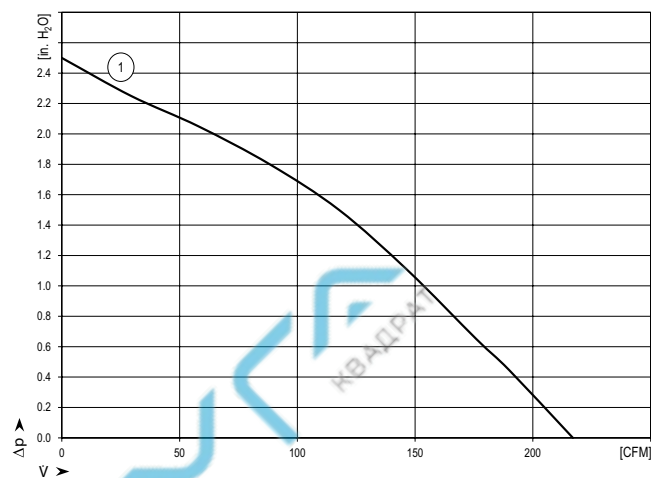

Curves

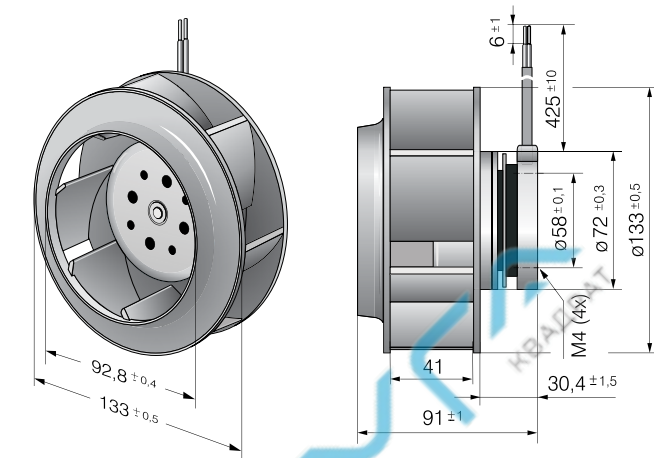
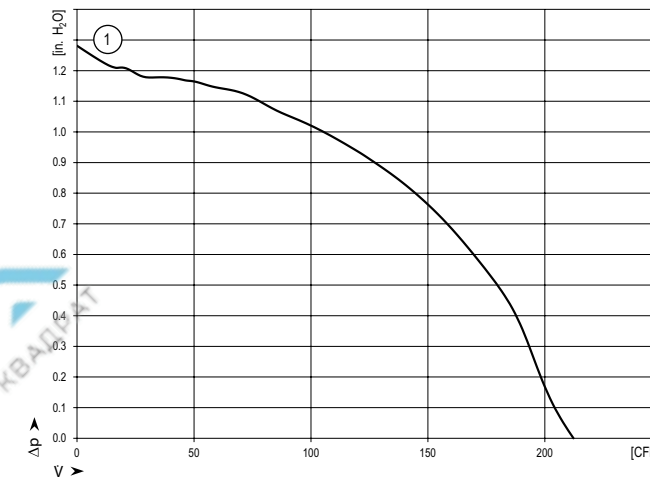

IP68
RATING

КВАДРАТ

DC centrifugal fans

Series RER 190 TDU Ø190 x 69 mm



Highlights:

- Backward curved RadiCal impeller with maximum efficiency and 3-phase motor
- Motor protection against reverse polarity and locking
- Direction of air flow: axial air intake, centrifugal air exhaust
- Connection via single strands AWG 22, TR 64, speed signal and control input AWG 22, bared and tin-plated
- Ingress protection rating of IP68

Material: Impeller: Fiberglass-reinforced composite

Direction of rotation: Clockwise, seen on rotor

IP68
RATING

КВАДРАТ

DC centrifugal fans

Series RER 175 TDU Ø175 x 69 mm



Highlights:

- Backward curved impeller with 3-phase motor
- Motor protection against reverse polarity and locking
- Direction of air flow: axial air intake, centrifugal air exhaust
- Connection via single strands AWG 22, TR 64, speed signal and control input AWG 22, bared and tin-plated
- Available as standard with PWM control input and speed signal
- Ingress protection rating of IP68

Material: Impeller: Fiberglass-reinforced composite

Direction of rotation: Clockwise, seen on rotor

Nominal Data

Type	Air flow CFM	Nominal voltage VDC	Voltage range VDC	Sound pressure level dB(A)	Sound power level Bel(A)	Ball bearings	Power input Watts	Speed RPM	Temperature range °C	Mass g	Ingress Protection Rating	UL Approval	Curves
RER 190-39/14/2TDLOU	376.7	24	16...30	-	6.8	Yes	57.1	2900	-20...60	870	IP68	Yes	1

Nominal Data

Type	Air flow CFM	Nominal voltage VDC	Voltage range VDC	Sound pressure level dB(A)	Sound power level Bel(A)	Ball bearings	Power input Watts	Speed RPM	Temperature range °C	Mass g	Ingress Protection Rating	UL Approval	Curves
RER 175-42/14/2TDMLPU	353.0	24	16...30	-	7.3	Yes	48	3400	-20...65	775	IP68	Yes	1

Curves

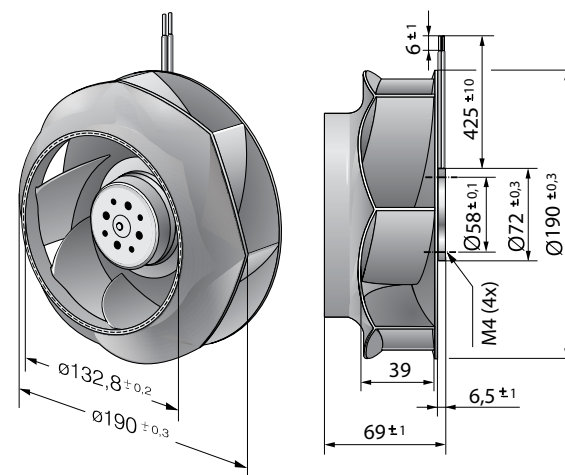
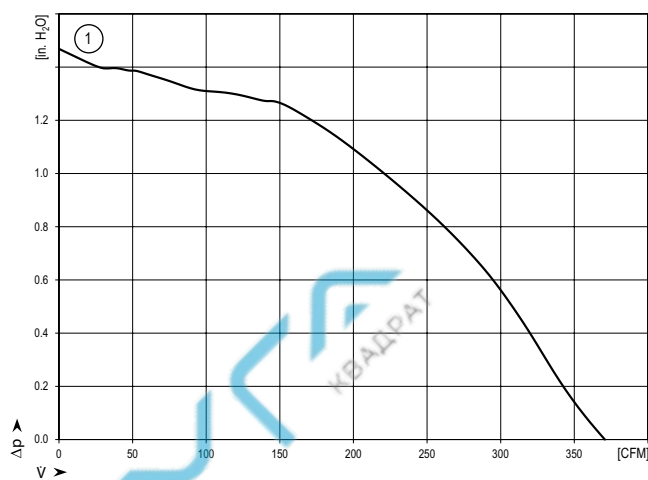

Curves

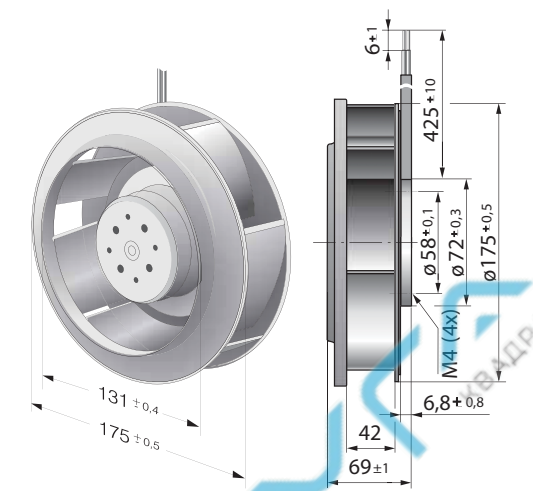
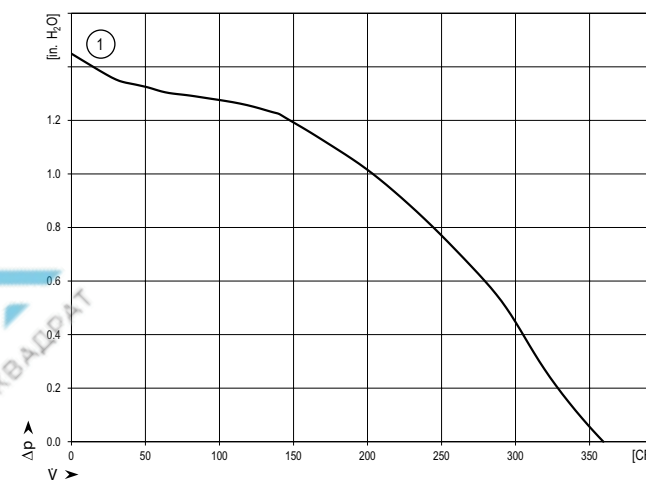



Notes



Notes



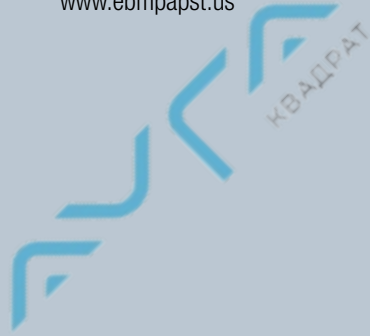

ebm-papst Inc.
North America

100 Hyde Road
Farmington, CT 06034
Phone + 1 860-674-1515
Fax + 1 860-674-8536
sales@us.ebmpapst.com
© ebm-papst Inc. 2016.

ebm-papst Inc. reserves the right to change any specifications or data without notice.

ebmpapst

The engineer's choice