

ebm-papst Mulfingen GmbH & Co. KG

Bachmühle 2 · D-74673 Mulfingen

Phone +49 7938 81-0

Fax +49 7938 81-110

info1@de.ebmpapst.com

www.ebmpapst.com

Limited partnership · Headquarters Mulfingen

County court Stuttgart · HRA 590344

General partner Elektrobau Mulfingen GmbH · Headquarters Mulfingen

County court Stuttgart · HRB 590142

Nominal data

Type	A6E500-AJ05-01		
Motor	M6E110-EF		
Phase		1~	1~
Nominal voltage	VAC	230	230
Frequency	Hz	50	60
Type of data definition		ml	ml
Valid for approval / standard		CE	CE
Speed (rpm)	min ⁻¹	865	810
Power input	W	220	290
Current draw	A	0.97	1.3
Motor capacitor	µF	5	5
Capacitor voltage	VDB	400	400
Max. back pressure	Pa	60	57
Min. ambient temperature	°C	-40	-40
Max. ambient temperature	°C	80	70
Starting current	A	1.7	1.51

ml = Max. load · me = Max. efficiency · fa = Running at free air · cs = Customer specs · cu = Customer unit
Subject to alterations

Data in accordance with ecodesign regulation EU 327/2011 (EN 17166)

		Actual	Request 2015			
01 Overall efficiency η_{es}	%	29.6	29.4	09 Power input P_e	kW	0.2
02 Measurement category		A		09 Air flow q_v	m ³ /h	4050
03 Efficiency category		Static		09 Pressure increase p_{fs}	Pa	55
04 Efficiency grade N		40.2	40	10 Speed (rpm) n	min ⁻¹	875
05 Variable speed drive		No		11 Specific ratio*		1.00

Data definition with optimum efficiency.
The ErP data is determined using a motor-impeller combination in a standardised measurement configuration.

* Specific ratio = $1 + p_{fs} / 100\,000\text{ Pa}$

LU-199819

A6E500-AJ05-01

AC axial fan - HyBlade

sickled blades (S series)

Technical features

Mass	7.6 kg
Size	500 mm
Motor size	110
Surface of rotor	Coated in black
Material of terminal box	PP plastic
Material of blades	Press-fitted sheet steel blank, sprayed with PP plastic
Number of blades	5
Direction of air flow	V
Direction of rotation	Counter-clockwise, seen on rotor
Type of protection	IP54
Insulation class	"F"
Humidity (F) / environmental protection class (H)	H2
Max. permissible ambient motor temp. (transp./ storage)	+ 80 °C
Min. permissible ambient motor temp. (transp./storage)	- 40 °C
Mounting position	Shaft horizontal or rotor on bottom; rotor on top on request
Condensation drainage holes	Rotor-side
Operation mode	S1
Motor bearing	Ball bearing
Touch current acc. IEC 60990 (measuring network Fig. 4, TN system)	<= 3.5 mA
Electrical connection	Terminal box; Via terminal box, capacitor integrated and connected
Motor protection	Thermal overload protector (TOP) brought out, basic insulation
Protection class	I (if protective earth is connected by customer)
Motor capacitor according to EN 60252-1 in safety protection class	S0
Product conforming to standard	EN 61800-5-1; CE
Approval	VDE; CCC; EAC

A6E500-AJ05-01

AC axial fan - HyBlade

sickled blades (S series)

Product drawing

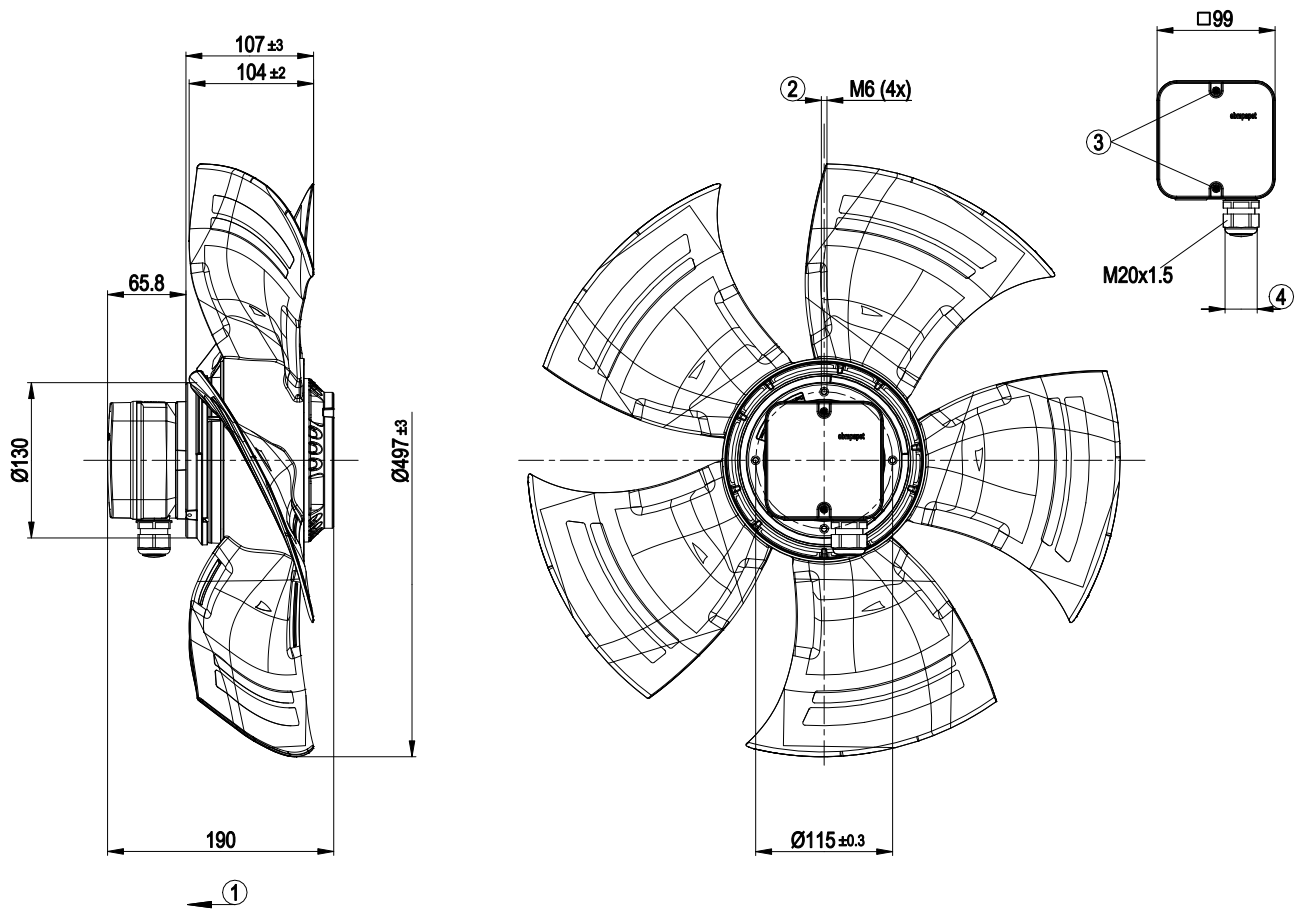

1	Direction of air flow "V"
2	Thread reach max. 12 mm
3	Tightening torque 1.5 ± 0.2 Nm
4	Cable diameter: min. 6 mm, max. 12 mm; tightening torque 2 ± 0.3 Nm

Connection screen

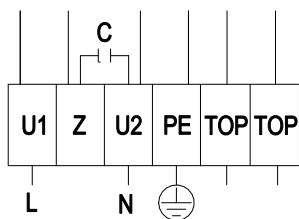

L	= U1 = blue	Z	brown	N	= U2 = black
PE	green / yellow	TOP	grey		

Charts: Air flow 50 Hz

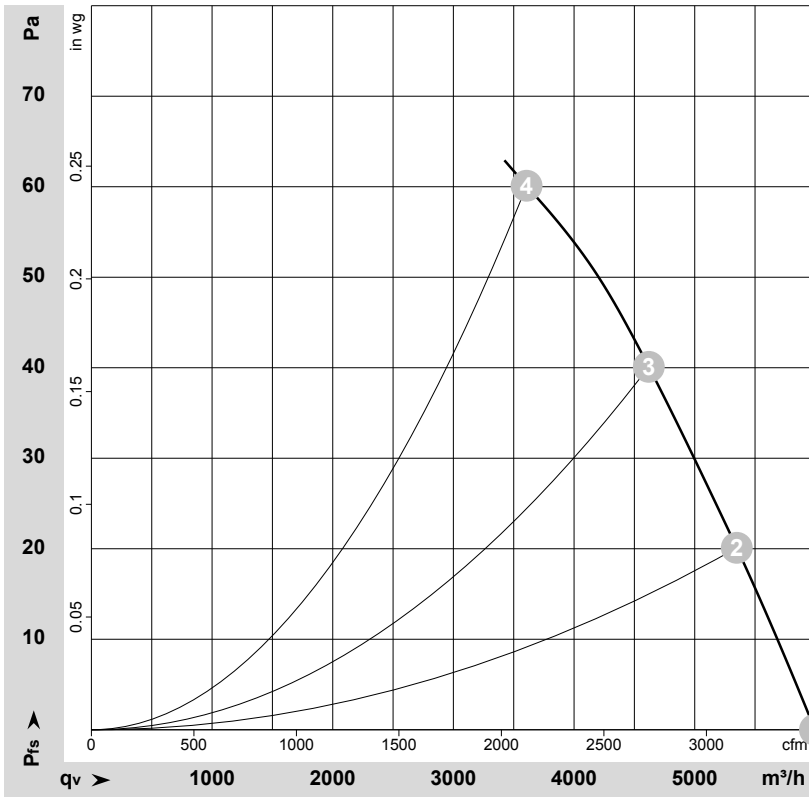

$\rho = 1.15 \text{ kg/m}^3 \pm 2 \%$

Measurement: LU-136414-1

Air performance measured as per ISO 5801 Installation category A. For detailed information on the measuring set-up, please contact ebm-papst. Suction-side noise levels: LwA measured as per ISO 13347 / LpA measured with 1m distance to fan axis. The values given are valid under the measuring conditions mentioned above and may vary according to the actual installation situation. With any deviation from the standard set-up, the specific values have to be checked and reviewed with the unit installed.

Measured values

	U	f	n	Pe	I	LpA _{in}	LwA _{in}	LwA _{out}	qv	Pfs	qv	Pfs
	V	Hz	min ⁻¹	W	A	dB(A)	dB(A)	dB(A)	m ³ /h	Pa	cfm	in. wg
1	230	50	915	175	0.76	60	66	66	5995	0	3530	0.00
2	230	50	900	190	0.83	57	64	64	5350	20	3150	0.08
3	230	50	885	204	0.89	55	62	62	4620	40	2720	0.16
4	230	50	865	220	0.97	54	61	60	3605	60	2125	0.24

U = Supply voltage · f = Frequency · n = Speed (rpm) · Pe = Power input · I = Current draw · LpA_{in} = Sound pressure level inlet side · LwA_{in} = Sound power level inlet side · LwA_{out} = Sound power level outlet side
 qv = Air flow · Pfs = Pressure increase

Charts: Air flow 60 Hz

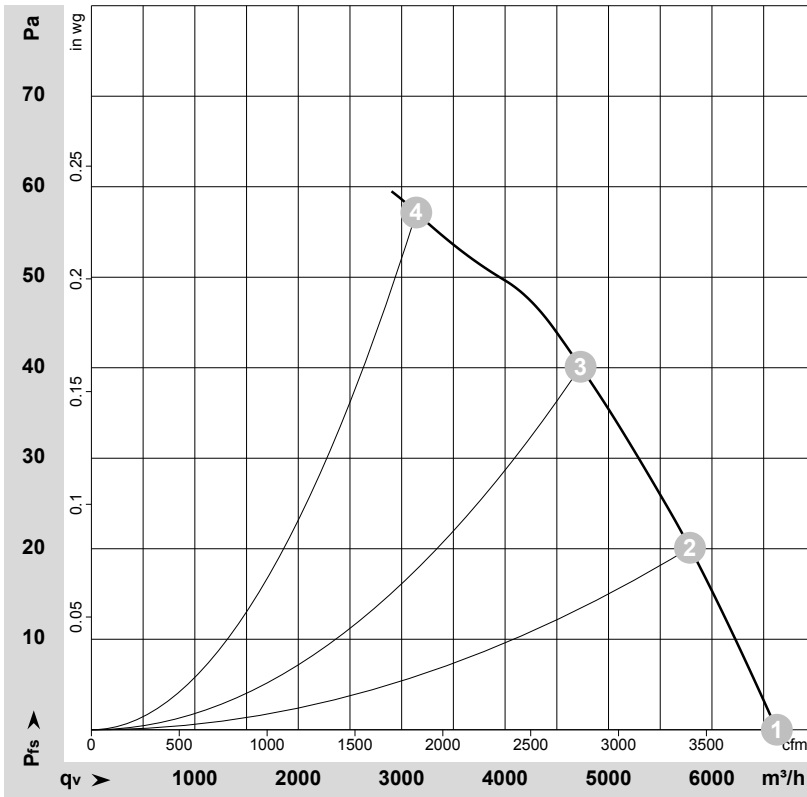

$\rho = 1.15 \text{ kg/m}^3 \pm 2 \%$

Measurement: LU-136419-1

Air performance measured as per ISO 5801 Installation category A. For detailed information on the measuring set-up, please contact ebm-papst. Suction-side noise levels: LwA measured as per ISO 13347 / LpA measured with 1m distance to fan axis. The values given are valid under the measuring conditions mentioned above and may vary according to the actual installation situation. With any deviation from the standard set-up, the specific values have to be checked and reviewed with the unit installed.

Measured values

	U	f	n	Pe	I	LpA _{in}	LwA _{in}	LwA _{out}	qv	Pfs	qv	Pfs
	V	Hz	min ⁻¹	W	A	dB(A)	dB(A)	dB(A)	m ³ /h	Pa	cfm	in. wg
1	230	60	1010	255	1.11	62	69	68	6630	0	3900	0.00
2	230	60	965	268	1.17	59	66	65	5785	20	3405	0.08
3	230	60	900	280	1.24	56	63	63	4730	40	2785	0.16
4	230	60	810	290	1.30	54	61	61	3140	57	1850	0.23

U = Supply voltage · f = Frequency · n = Speed (rpm) · Pe = Power input · I = Current draw · LpA_{in} = Sound pressure level inlet side · LwA_{in} = Sound power level inlet side · LwA_{out} = Sound power level outlet side
 qv = Air flow · Pfs = Pressure increase