

# DC Axial Fans

ebmpapst

Series 4100 N, Type 4182 NGX 119 x 119 x 38 mm

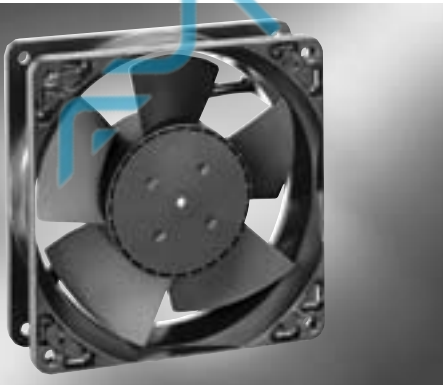

- DC fans with electronically commutated external rotor motor. Fully integrated commutation electronics.
- With electronic protection against reverse polarity, blocking and overloading by PTC-resistor; partially impedance protected.
- Metal fan housing. Impeller of fibre-glass reinforced plastic PA. Housing with ground lug M4 for M4 x 8 screws.
- Air intake over struts. Rotational direction CW looking at rotor.
- Optional Vario-Pro: Highly adaptable software configuration of the fan enables a tailor-made solution to the specific requirements of your applications.
- Electrical connection via 2 flat pins 2,8 x 0,5 mm.
- Mass 390 g.

ebm-papst • St. Georgen

Nominal Data	Air Flow	Air Flow	Nominal Voltage	Voltage Range	Noise	Sinter-Sleeve Bearings	Ball Bearings	Power Input	Nominal Speed	Temperature Range	Service Life L <sub>10</sub>		Curve
	m <sup>3</sup> /h	CFM									V DC	V DC	
4182 NGX	160	94.2	12	7...15	44	5.3	□	3.5	2 800	-10...+75	85 000 / 37 500	1	
4182 NX	180	105.9	12	7...15	49	5.7	■	4.5	3 200	-30...+75	85 000 / 37 500	2	
4182 NXH	237	139.5	12	7...14	59	6.5	■	11	4 400	-30...+55	70 000 / 50 000	2	
4184 NGX	160	94.2	24	12...30	44	5.3	□	3.5	2 800	-10...+75	85 000 / 37 500	1	
4184 NX	180	105.9	24	12...29	49	5.7	■	4.5	3 200	-30...+75	85 000 / 37 500	2	
4184 NXH	237	139.5	24	12...25	59	6.5	■	11	4 400	-30...+55	70 000 / 50 000	3	
4184 NXHH	250	147.1	24	12...25	60	6.7	■	12.2	4 900	-30...+55	70 000 / 52 500	4	
4188 NXM	160	94.2	48	36...56	44	5.3	■	3.5	2 800	-30...+75	85 000 / 37 500	1	
<b>Programmable fan Vario-Pro (electr. connection via leads)</b>													
4112 NHH	270	158.9	12	11...13	64	7.0	■	15.5	5 000	-20...+50	70 000 / 55 000	5	
4114 NHH	270	158.9	24	18...26.4	64	7.0	■	15.5	5 000	-20...+60	70 000 / 52 500	5	
4118 NHH	270	158.9	48	44...52	64	7.0	■	15.5	5 000	-10...+55	70 000 / 52 500	5	

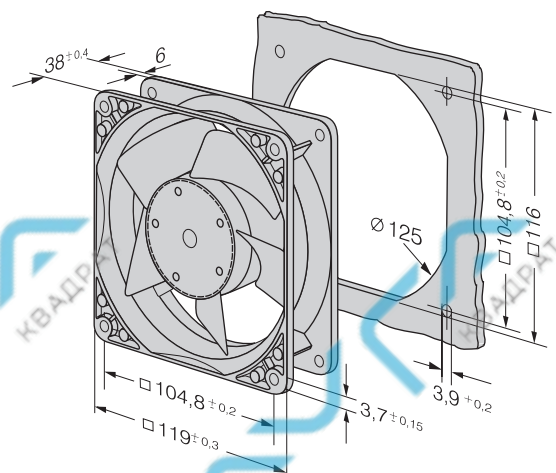
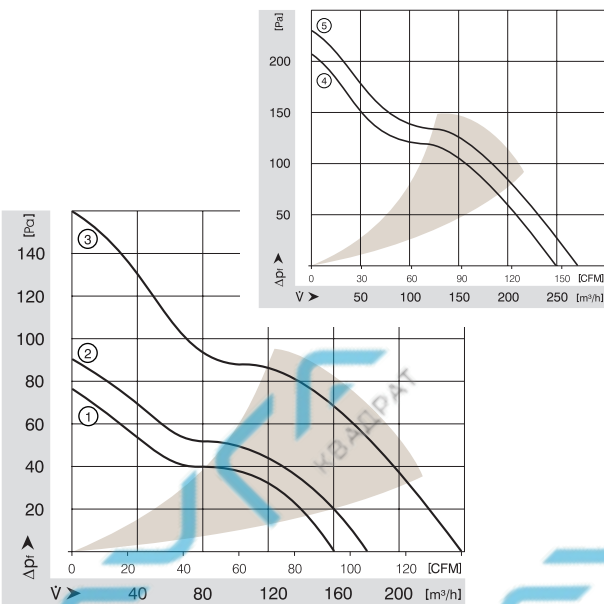

# Sensor signal /2



- Speed-proportional rectangular pulse for external speed monitoring of fan motor
- 2 pulses per revolution
- Open-Collector signal output
- Extremely wide operating voltage range (5 ... 60 V)
- Easy adaptation to user interface
- Connection via separate lead
- The sensor signal also serves as a major comparison variable for setting and maintaining the desired speed for interactive or controlled cooling with one or several interconnected fans.

ebm-papst • St. Georgen

## Electrical connection

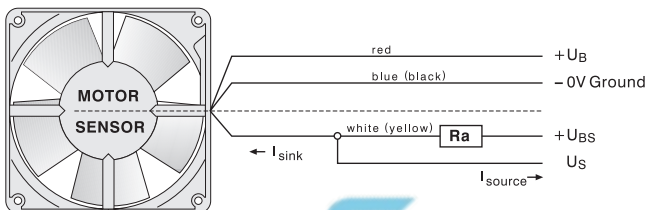

$$R_a = \frac{U_{BS} - U_{SLOW}}{I_{SINK}}$$

All voltages measured to ground.  
External load resistance Ra from US to UBS required.

## Signal output voltage

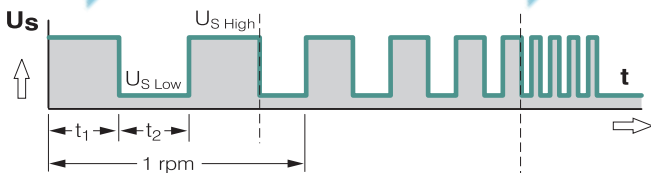

## Fan speed

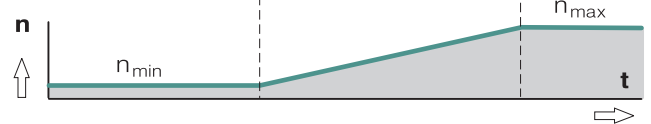

Signal symmetry  $[t_1, t_2] = 0.8 \dots 1.2$   
Signal frequency  $[F] = 2 \times n / 60 \text{ Hz}$

### Attention:

With these fan options, deviations in regard to temperature range, voltage range and power consumption are possible compared with standard fan data.

## Signal data

Type	Sensor signal $U_{S \text{ Low}}$	Condition: $I_{\text{sink}}$	Sensor signal $U_{S \text{ High}}$	Condition: $I_{\text{source}}$	Sensor operating voltage $U_{BS}$	Perm. sink current $I_{\text{sink max.}}$
	V DC	mA	V DC	mA	V DC	mA
255 N/2	≤ 0.4	≤ 2	30	0	≤ 30	2
255 H/2	≤ 0.4	≤ 2	30	0	≤ 30	2
252 N/2	≤ 0.4	≤ 2	30	0	≤ 30	2
405 F/2	≤ 0.4	1	30	0	≤ 30	≤ 2
405 F/2 H	≤ 0.4	1	30	0	≤ 30	≤ 2
412 F/2 H	≤ 0.4	1	30	0	≤ 30	≤ 2
414 F/2	≤ 0.4	1	30	0	≤ 30	≤ 2
405 /2	≤ 0.4	1	30	0	≤ 30	≤ 2
412 /2	≤ 0.4	1	30	0	≤ 30	≤ 2
414 /2	≤ 0.4	1	30	0	≤ 30	≤ 2
414 /2 H	≤ 0.4	1	30	0	≤ 30	≤ 2
412 J/2 H	≤ 0.4	1	30	0	≤ 30	≤ 4
412 J/2 HH	≤ 0.4	1	30	0	≤ 30	≤ 4
414 J/2 H	≤ 0.4	2	30	0	≤ 30	≤ 4
414 J/2 HH	≤ 0.4	2	30	0	≤ 30	≤ 4
512 F/2	≤ 0.4	1	30	0	≤ 30	≤ 2
514 F/2	≤ 0.4	1	30	0	≤ 30	≤ 2
612 F/2	≤ 0.4	1	30	0	≤ 30	≤ 2
612 F/2 H	≤ 0.4	1	30	0	≤ 30	≤ 2
614 F/2	≤ 0.4	1	30	0	≤ 30	≤ 2
612 N/2 H	≤ 0.4	1	30	0	≤ 30	≤ 2
612 N/2 NHH-120	≤ 0.4	1	30	0	≤ 30	≤ 2
612 N/2 N	≤ 0.4	1	30	0	≤ 30	≤ 2
614 N/2 H	≤ 0.4	1	30	0	≤ 30	≤ 2
614 N/2 HH-121	≤ 0.4	1	30	0	≤ 30	≤ 2
614 N/2 M	≤ 0.4	2	28	0	≤ 30	≤ 4
712 F/2 L	≤ 0.4	1	30	0	≤ 30	≤ 2
712 F/2 M	≤ 0.4	1	30	0	≤ 30	≤ 2
8412 N/2 GL	≤ 0.4	2	28	0	≤ 28	≤ 4
8412 N/2 GM	≤ 0.4	2	28	0	≤ 28	≤ 4
8412 N/2 G	≤ 0.4	2	28	0	≤ 28	≤ 4
8414 N/2 GL	≤ 0.4	2	28	0	≤ 28	≤ 4
8414 N/2 GM	≤ 0.4	2	28	0	≤ 28	≤ 4
8414 N/2 G	≤ 0.4	2	28	0	≤ 28	≤ 4
8414 N/2	≤ 0.4	2	28	0	≤ 28	≤ 4
8412 N/2	≤ 0.4	2	28	0	≤ 28	≤ 4
8412 N/2 H	≤ 0.4	2	28	0	≤ 28	≤ 4
8414 N/2 H	≤ 0.4	2	28	0	≤ 28	≤ 4
8312 /2 HL	≤ 0.4	2	30	0	≤ 30	≤ 4
8314 /2	≤ 0.4	2	30	0	≤ 30	≤ 4
8314 /2 H	≤ 0.4	2	30	0	≤ 30	≤ 4

**Available on request:**

- Galvanically separated sensor signal circuit
- Varying voltage potentials for power and logic circuit.

Signal data		Sensor signal $U_{S, Low}$	Condition: $I_{sink}$	Sensor signal $U_{S, High}$	Condition: $I_{source}$	Sensor operating voltage $U_{BS}$	Perm. sink current $I_{sink, max.}$
Type	V DC	mA	V DC	mA	V DC	mA	
8318 /2	≤ 0.4	2	30	0	≤ 30	≤ 4	
8318 /2 HL	≤ 0.4	2	30	0	≤ 30	≤ 4	
8318 /2 H	≤ 0.4	2	30	0	≤ 30	≤ 4	
3412 N/2 GL	≤ 0.4	2	28	0	≤ 28	≤ 4	
3412 N/2 GM	≤ 0.4	2	28	0	≤ 28	≤ 4	
3412 N/2	≤ 0.4	2	28	0	≤ 28	≤ 4	
3412 N/2 G	≤ 0.4	2	28	0	≤ 28	≤ 4	
3412 N/2 HH	≤ 0.4	2	28	0	≤ 28	≤ 4	
3412 N/2 GHH	≤ 0.4	2	28	0	≤ 28	≤ 4	
3412 N/2 H	≤ 0.4	2	28	0	≤ 28	≤ 4	
3414 N/2 GH	≤ 0.4	2	28	0	≤ 28	≤ 4	
3414 N/2	≤ 0.4	2	28	0	≤ 28	≤ 4	
3312 /2	≤ 0.4	2	30	0	≤ 30	≤ 4	
3318 /2	≤ 0.4	2	30	0	≤ 30	≤ 4	
4412 F/2 GL	≤ 0.4	2	30	0	≤ 30	≤ 4	
4412 F/2 GML	≤ 0.4	2	30	0	≤ 30	≤ 4	
4412 F/2 M	≤ 0.4	2	30	0	≤ 30	≤ 4	
4412 F/2	≤ 0.4	2	30	0	≤ 30	≤ 4	
4414 F/2 L	≤ 0.4	2	30	0	≤ 30	≤ 4	
4414 F/2 M	≤ 0.4	2	30	0	≤ 30	≤ 4	
4414 F/2 G	≤ 0.4	2	30	0	≤ 30	≤ 4	
4414 F/2	≤ 0.4	2	30	0	≤ 30	≤ 4	
4418 F/2	≤ 0.4	2	30	0	≤ 30	≤ 4	
4312 N/2 H	≤ 0.4	2	30	0	≤ 30	≤ 4	
4312 N/2 HH	≤ 0.4	2	30	0	≤ 30	≤ 4	
4312 /2	≤ 0.4	2	30	0	≤ 30	≤ 4	
4314 /2 G	≤ 0.4	2	30	0	≤ 30	≤ 4	
4314 /2	≤ 0.4	2	30	0	≤ 30	≤ 4	
4318 /2 G	≤ 0.4	2	30	0	≤ 30	≤ 4	
4318 /2 M	≤ 0.4	2	30	0	≤ 30	≤ 4	
4318 /2	≤ 0.4	2	30	0	≤ 30	≤ 4	
4212 N/2 GN	≤ 0.4	2	30	0	≤ 30	≤ 4	
4212 N/2 H	≤ 0.4	2	30	0	≤ 30	≤ 4	
4214 N/2 GN	≤ 0.4	2	30	0	≤ 30	≤ 4	
4214 N/2 H	≤ 0.4	2	30	0	≤ 30	≤ 4	
4218 N/2 GN	≤ 0.4	2	30	0	≤ 30	≤ 4	
4218 N/2 H	≤ 0.4	2	30	0	≤ 30	≤ 4	
4212 /2 M	≤ 0.4	2	30	0	≤ 30	≤ 4	
4212 /2	≤ 0.4	2	30	0	≤ 30	≤ 4	
4212 /2 H	≤ 0.4	2	30	0	≤ 30	≤ 4	
4214 /2	≤ 0.4	2	30	0	4-30	≤ 4	

Signal data		Sensor signal $U_{S, Low}$	Condition: $I_{sink}$	Sensor signal $U_{S, High}$	Condition: $I_{source}$	Sensor operating voltage $U_{BS}$	Perm. sink current $I_{sink, max.}$
Type	V DC	mA	V DC	mA	V DC	mA	
4214 /2 H	≤ 0.4	2	30	0	4-30	≤ 4	
4218 /2	≤ 0.4	2	30	0	4-30	≤ 4	
4218 /2 H	≤ 0.4	2	30	0	4-30	≤ 4	
4182 N/2 X	≤ 0.4	2	30	0	4-30	≤ 4	
4182 N/2 GX	≤ 0.4	2	30	0	4-30	≤ 4	
4184 N/2 GX	≤ 0.4	2	30	0	4-30	≤ 4	
4184 N/2 X	≤ 0.4	2	30	0	4-30	≤ 4	
4184 N/2 XH	≤ 0.4	2	30	0	4-30	≤ 4	
5112 N/2	≤ 0.4	2	15	0	≤ 5	≤ 20	
5114 N/2	≤ 0.4	2	60	0	≤ 60	≤ 20	
5118 N/2	≤ 0.4	2	60	0	≤ 60	≤ 20	
5212 N/2 H	≤ 0.4	2	30	0	4-30	≤ 2	
5212 N/2 N	≤ 0.4	2	30	0	4-30	≤ 2	
5214 N/2 N	≤ 0.4	2	30	0	4-30	≤ 2	
5218 N/2 H	≤ 0.4	2	30	0	4-30	≤ 2	
7112 N/2	≤ 0.4	2	60	0	≤ 60	≤ 20	
7114 N/2	≤ 0.4	2	30	0	≤ 30	≤ 20	
7118 N/2	≤ 0.4	2	60	0	≤ 60	≤ 20	
6224 N/2	≤ 0.4	8	30	0	≤ 30	≤ 20	
6248 N/2	≤ 0.4	8	60	0	≤ 30	≤ 20	
DV 6224 /2	≤ 0.4	2	30	0	≤ 60	≤ 20	
6424 /2	≤ 0.4	2	60	0	≤ 60	≤ 20	
6448 /2	≤ 0.4	2	60	0	≤ 60	≤ 20	
6448 /2 T	≤ 0.4	2	60	0	≤ 60	≤ 20	
RL 48-19/12/2	≤ 0.4	2	28	0	4-30	≤ 4	
RL 48-19/14/2	≤ 0.4	2	28	0	4-30	≤ 4	
RL 90-18/12N/2	≤ 0.4	2	30	0	≤ 30	≤ 4	
RL 90-18/14N/2	≤ 0.4	2	30	0	≤ 30	≤ 4	
RG 90-18/12N/2	≤ 0.4	2	30	0	≤ 30	≤ 4	
RG 90-18/14N/2	≤ 0.4	2	30	0	≤ 30	≤ 4	
RG 125-19/14N/2	≤ 0.4	2	30	0	≤ 30	≤ 4	
RG 125-19/18N/2	≤ 0.4	2	60	0	≤ 30	≤ 4	
RER 125-19/14N/2	≤ 0.4	2	30	0	≤ 30	≤ 4	
RG 160-28/14N/2	≤ 0.4	2	30	0	≤ 30	≤ 20	

**Attention:**  
With these fan options, deviations in regard to temperature range, voltage range and power consumption are possible compared with standard fan data.

# Mouser Electronics

Authorized Distributor

Click to View Pricing, Inventory, Delivery & Lifecycle Information:

[ebm-papst:](#)

[RL48-19/12/2](#)

