

A4Q254-AR01-06

AC axial fan

sickle-shaped blades (S series)

ebm-papst Mulfingen GmbH & Co. KG

Bachmühle 2 · D-74673 Mulfingen

Phone +49 7938 81-0

Fax +49 7938 81-110

info1@de.ebmpapst.com

www.ebmpapst.com

Limited partnership · Headquarters Mulfingen

Amtsgericht (court of registration) Stuttgart · HRA 590344

General partner Elektrobau Mulfingen GmbH · Headquarters Mulfingen

Amtsgericht (court of registration) Stuttgart · HRB 590142

Nominal data

Type	A4Q254-AR01-06		
Motor	M4Q045-DA		
Phase		1~	1~
Nominal voltage	VAC	230	230
Frequency	Hz	50	60
Method of obtaining data		me	me
Valid for approval/standard		CE	CE
Speed (rpm)	min ⁻¹	1300	1550
Power consumption	W	70	62
Current draw	A	0.48	0.42
Max. back pressure	Pa	20	30
Max. back pressure	in. wg	0.08	0.12
Min. ambient temperature	°C	-30	-30
Max. ambient temperature	°C	40	40
Starting current	A	0.75	0.72

ml = Max. load · me = Max. efficiency · fa = Free air · cs = Customer specification · ce = Customer equipment
Subject to change



AC axial fan

sickle-shaped blades (S series)

Technical description

Weight	1.7 kg
Size	254 mm
Motor size	45
Blade material	Sheet aluminum
Number of blades	5
Airflow direction	V
Direction of rotation	Counterclockwise, viewed toward rotor
Degree of protection	IP42
Insulation class	"B"
Moisture (F) / Environmental (H) protection class	H1
Max. permitted ambient temp. for motor (transport/storage)	+ 80 °C
Min. permitted ambient temp. for motor (transport/storage)	- 40 °C
Installation position	Any, preferably horizontal
Condensation drainage holes	None
Mode	S1
Motor bearing	Calotte bearing
Touch current according to IEC 60990 (measuring circuit Fig. 4, TN system)	< 0.75 mA
Motor protection	Thermal overload protector (TOP) internally connected
With cable	Lateral
Protection class	I (with customer connection of protective earth)
Conformity with standards	EN 60335-1; CE
Approval	VDE; EAC

AC axial fan

sickle-shaped blades (S series)

Product drawing

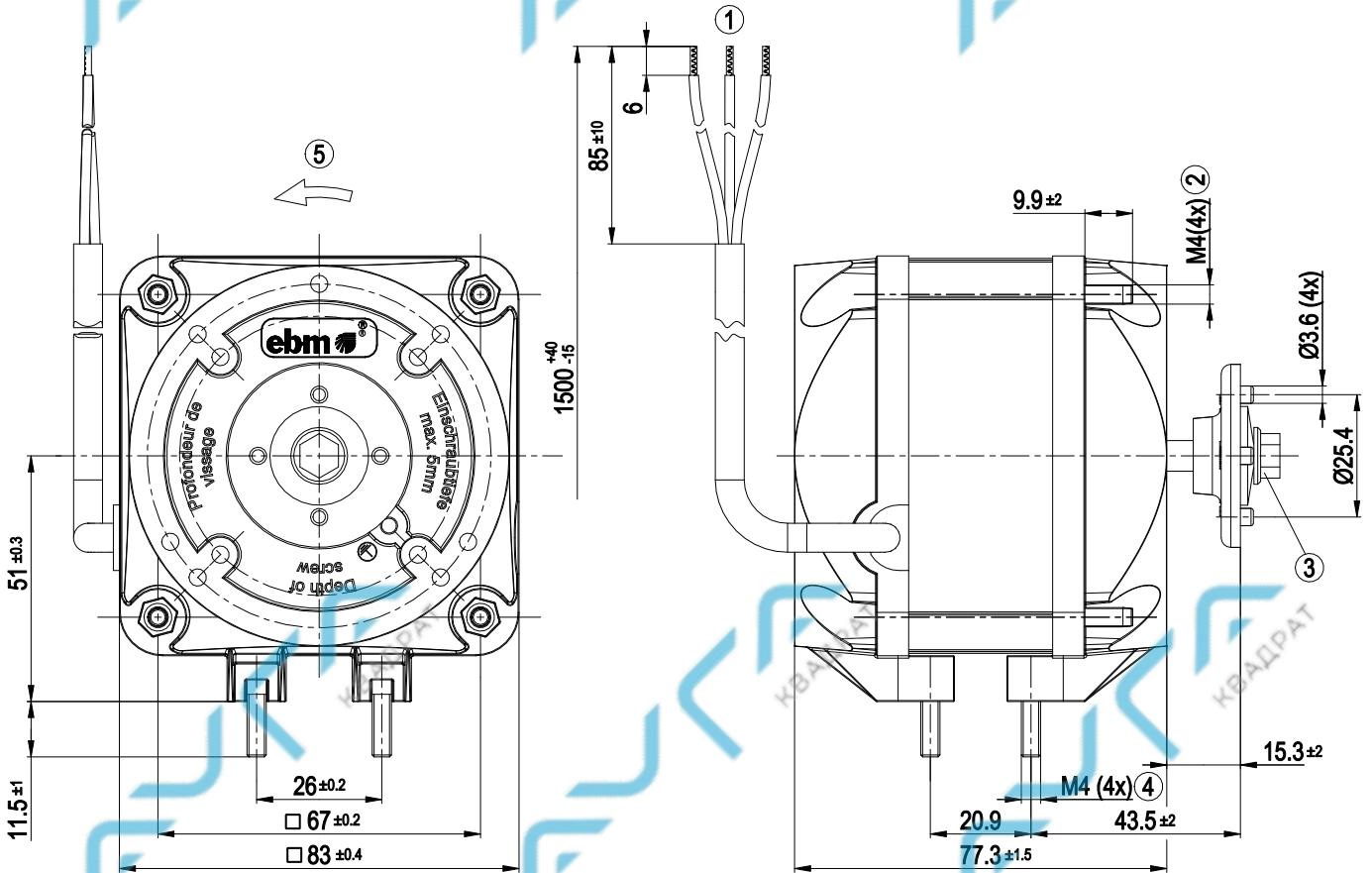

1	Cable PVC 3G 0.5 mm ² 3x splice
2	Tightening torque for nut for fastening fan housing or guard grill 2.3 Nm
3	Tightening torque for screw for fastening fan impeller 1.4 Nm
4	Tightening torque for nuts to fasten mounting bracket: 2.3 Nm
5	Direction of rotation counterclockwise, viewed toward shaft end



A4Q254-AR01-06

AC axial fan

sickle-shaped blades (S series)

Accessory part

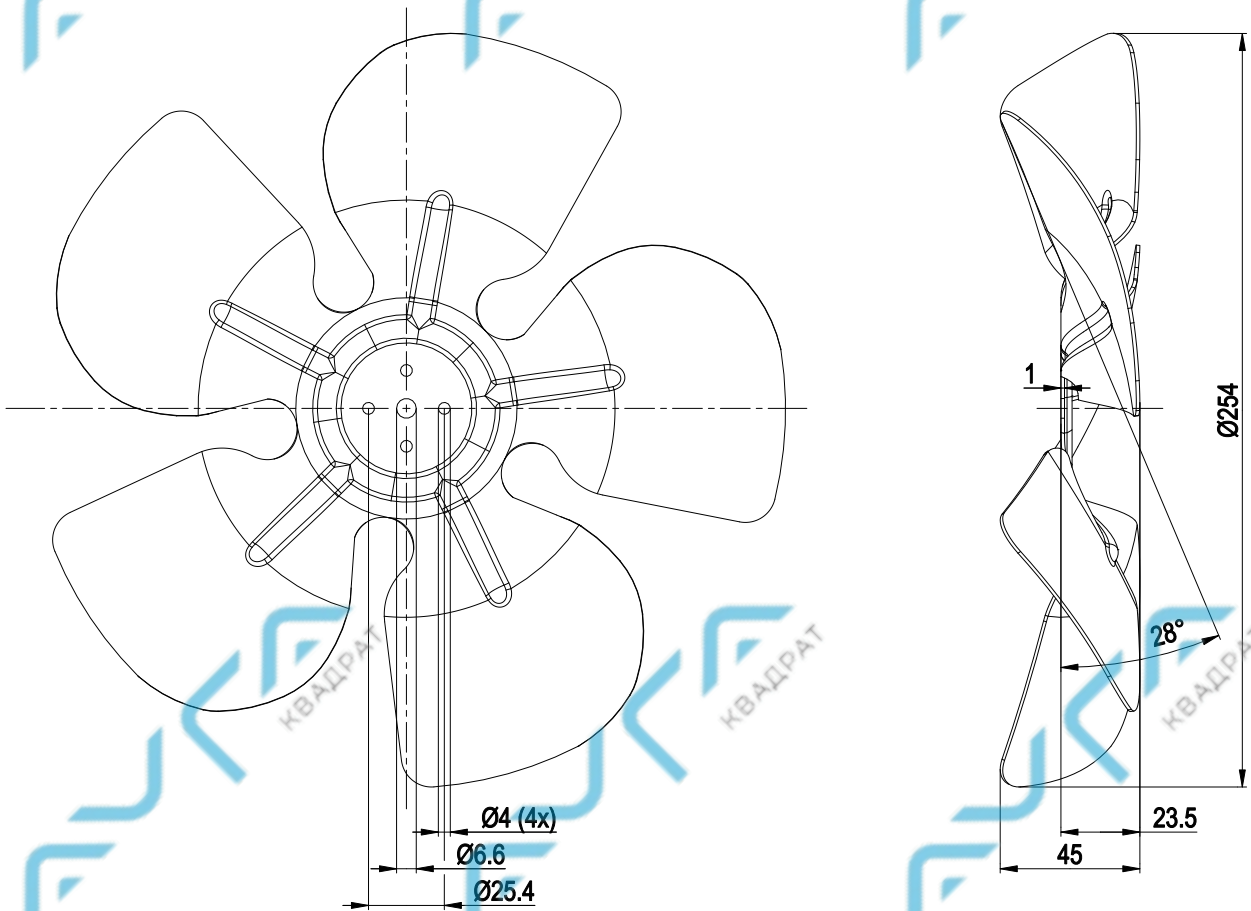

Axial fan impeller 73814-2-3634 included separately

Airflow direction "V"

Connection diagram

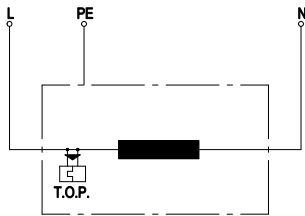

L	= blue
PE	= green/yellow
N	= brown
TOP	= thermal overload protector



AC axial fan

sickle-shaped blades (S series)

Curves: Air performance 50 Hz

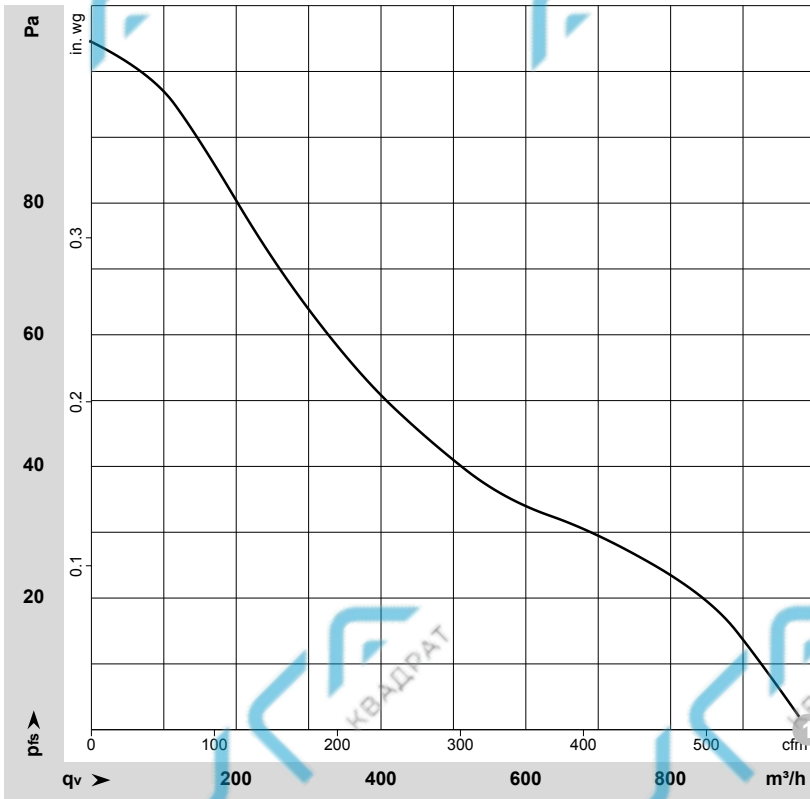

$\rho = 1.15 \text{ kg/m}^3 \pm 2 \%$

Measurement: LU-32017-1

Air performance measured according to ISO 5801 installation category A. For detailed information on the measurement setup, contact ebm-papst. Intake sound level: Sound power level according to ISO 13347 / sound pressure level measured at 1 m distance from fan axis. The values given are valid under the specified measuring conditions and may vary due to conditions of installation. For deviations from the standard configuration, the parameters have to be checked on the installed unit.

Measured values

	Wired	U	f	n	P _e	I	q _v	q _v	P _{fs}
		V	Hz	min ⁻¹	W	A	m ³ /h	cfm	in. wg
1	1~	230	50	1300	70	0.48	990	585	0.00

Wired = Wiring · U = Voltage · f = Frequency · n = Speed (rpm) · P_e = Power consumption · I = Current draw · q_v = Air flow



AC axial fan

sickle-shaped blades (S series)

Curves: Air performance 60 Hz

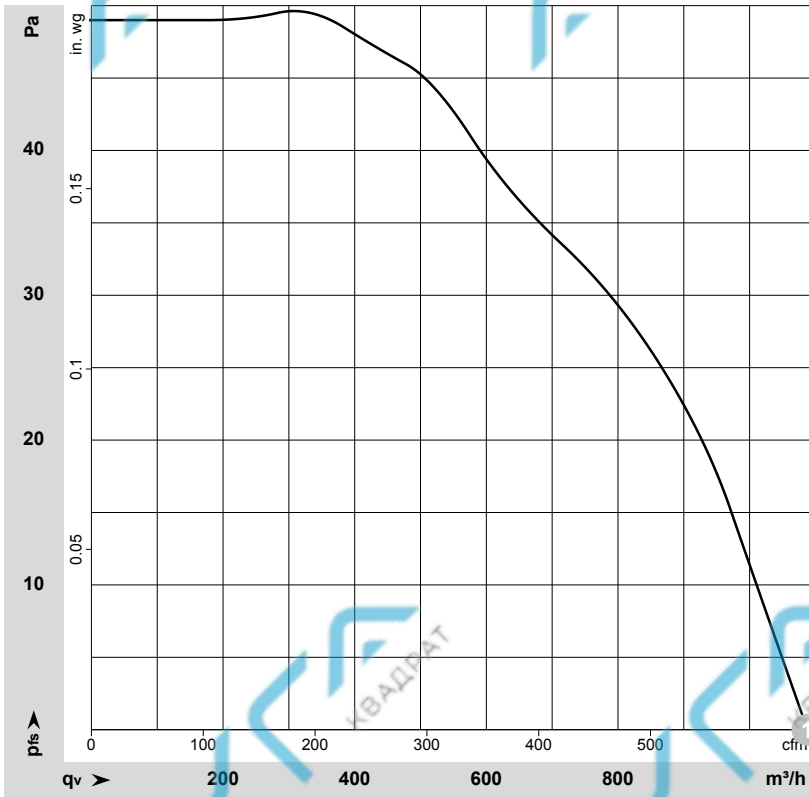

$\rho = 1.15 \text{ kg/m}^3 \pm 2 \%$

Measurement: LU-32018-1

Air performance measured according to ISO 5801 installation category A. For detailed information on the measurement setup, contact ebm-papst. Intake sound level: Sound power level according to ISO 13347 / sound pressure level measured at 1 m distance from fan axis. The values given are valid under the specified measuring conditions and may vary due to conditions of installation. For deviations from the standard configuration, the parameters have to be checked on the installed unit.

Measured values

	Wired	U	f	n	P _e	I	q _v	q _v	p _{st}
		V	Hz	min ⁻¹	W	A	m ³ /h	cfm	in. wg
1	1~	230	60	1550	62	0.42	1090	640	0.00

Wired = Wiring · U = Voltage · f = Frequency · n = Speed (rpm) · P_e = Power consumption · I = Current draw · q_v = Air flow

