

DC axial fans



DC axial fan overview	25
DC axial fan / DC diagonal fan	29

DC axial fans

Technical information



Product line

ebm-papst offers you the widest full product line of DC axial and diagonal fans from 25 mm to 280 mm in size. Every single type of fan can be optimally integrated in the respective **device** concept. The highly economical brushless motor technology of these fans provides a unique variety of intelligent innovations at prices that would have been unthinkable a few years ago.

Electronic protection against reverse polarity

ebm-papst DC fans have electronically commutated drives with electronic protection against reverse polarity. The electronics are integrated in the fan's impeller hub to save space.

Product life expectancy

A distinctive feature of DC fan technology is the amazing product life expectancy. The outstanding efficiency of the brushless drive results in lower heat stress for the bearings, which significantly increases the service life of the fan.

Degree of protection

DC fans with sleeve and ball bearings are powered by class E insulated motors. All ebm-papst fans conform to the requirements of degree of protection IP 20. Fans conforming to IP 54 / IP 68 and special degrees of protection are also available.

Voltage range

Many of our DC fans can be operated on voltages that are up to 50 % lower and 25 % higher than their nominal voltage (see voltage range in the **technical tables**). This allows the air performance to be **adapted** to the cooling requirements and the noise to be reduced, even if the fan does not have a control input.

Closed-loop speed control and monitoring

Closed-loop speed control and function monitoring are becoming increasingly important in many applications. ebm-papst offers many fans in the standard design with a control input and open-collector speed signal.

S-Force

The S-Force fans with their extremely high blower capacity of up to 1100 m³/h and pressure increase of up to 1400 pascals are capable of dealing with the extreme heat load. If needed, these fans can produce up to 100 % more output under full load, and they work with a much broader delivery bandwidth than current models. This makes them ideal for equipment and systems with a high density of components. Thanks to intelligent motor features, they can be adapted individually for any application. S-Force fans are available in standard dimensions. The air flow rate is amazing!

S-Panther

S-Panther power delivered quietly. Wherever there is need for power and reduced noise, fans from the S-Panther range are the right solution. A strong pressure saddle curve at optimum air flow provides the power of a real big cat, an S-Panther.

Axial fans for DC operation

Overview of air performance

Dimension	Series	Air flow		Page
mm		m³/h	10 20 30 40 50 60 70 80 90 100 200 300 400 500 600 700 800 900 1000 2000 2500	
□ 25 x 8	250	2.3...4.6		29
□ 40 x 10	400 F	6...9		30
□ 40 x 20	400	10...13.5		31
□ 40 x 28	420 J	24...38		32
□ 50 x 15	500 F	11...20		33
□ 60 x 15	600 F	19...33		34
□ 60 x 25	620	21...67		35
□ 60 x 25	630	40...58		36
□ 60 x 25	600 N	21...56		37
□ 60 x 32	600 J	70...82		38
□ 70 x 15	700 F	28...44		39
□ 80 x 25	8450	32...117		40
□ 80 x 25	8400 N	33...79		41
S-Panther □ 80 x 32	8300 N	32...130		42/43
□ 80 x 38	8200 J	132...222		44
□ 80 x 38	CoR 8200 J	232		45
□ 92 x 25	3400 N	61...102		46
S-Panther □ 92 x 32	3300 N	56...133		47/48
S-Force □ 92 x 38	3200 J	130...280		49
S-Panther □ 92 x 38	3250 J	145...270		50
□ 119 x 25	4400 F	94...170		51
∅ 127	4400 F	91		52
□ 119 x 25	4400 FN	200...225		53
S-Panther □ 119 x 32	4300 N	100...285		54/55

Subject to change

Axial fans for DC operation

Overview of technically feasible designs

Axial fans		VDE, UL, CSA	SWTFC sleeve bearings / ball bearings	Speed signal	Go / NoGo alarm	Alarm with speed limit	External temperature sensor	Internal temperature sensor	PWM control input	Analog control input	Multi-options control input	Moisture protection	IP >= 54	IP 69	Salt spray protection	Reversible direction of rotation	Page
Dimension	mm	Series	OPTIONAL														P.
□ 25 x 8	250	ja	□	•	-	-	-	-	-	-	-	•	-	-	-	-	29
□ 40 x 10	400 F	ja	□	•	•	-	-	-	-	-	-	•	-	-	-	-	30
□ 40 x 20	400	ja	□	•	•	-	-	-	•	-	-	•	-	-	-	-	31
□ 40 x 28	420 J	ja	■	•	•	•	•	•	•	-	-	•	•	•	•	-	32
□ 50 x 15	500 F	ja	□	•	•	-	-	-	•	-	-	•	-	-	-	-	33
□ 60 x 15	600 F	ja	□	•	•	-	-	-	•	-	-	•	-	-	-	-	34
□ 60 x 25	620	ja	■	•	•	•	•	•	•	-	-	•	-	-	-	-	35
□ 60 x 25	630	ja	■	•	•	•	•	-	•	•	-	•	•	•	•	-	36
□ 60 x 25	600 N	ja	□/■	•	•	-	-	-	-	-	-	•	•	•	-	-	37
□ 60 x 32	600 J	ja	■	•	•	-	•	-	•	•	-	•	-	-	-	-	38
□ 70 x 15	700 F	ja	□	•	•	-	-	-	-	-	-	•	-	-	-	-	39
□ 80 x 25	8450	ja	■	•	•	•	•	•	•	•	-	•	-	-	-	-	40
□ 80 x 25	8400 N	ja	□/■	•	•	•	•	•	•	•	-	•	•	•	-	-	41
S-Panther □ 80 x 32	8300 N	ja	■	•	•	•	•	•	•	•	-	•	•	•	•	-	42/43
□ 80 x 38	8200 J	ja	■	•	•	•	•	•	•	•	-	•	•	•	-	-	44
□ 80 x 38	CoR 8200 J	ja	■	•	•	•	•	•	•	•	-	•	-	-	-	-	45
□ 92 x 25	3400 N	ja	□/■	•	•	•	•	•	•	•	-	•	•	•	-	-	46
S-Panther □ 92 x 38	3300 N	ja	■	•	•	•	•	•	•	•	-	•	•	•	•	-	47/48
S-Force □ 92 x 38	3200 J	ja	■	•	•	•	•	•	•	•	-	•	-	-	-	-	49
S-Panther □ 92 x 38	3250 J	ja	■	•	•	-	•	•	•	•	-	•	•	•	•	-	50
□ 119 x 25	4400 F	ja	□/■	•	•	•	•	•	•	•	-	•	-	-	-	-	51
∅ 172	4400 F	ja	□	•	•	•	•	•	•	•	-	•	-	-	•	-	52
□ 119 x 25	4400 FN	ja	■	•	•	•	•	•	•	•	-	•	-	-	-	-	53
S-Panther □ 119 x 32	4300 N	ja	■	•	•	•	•	•	•	•	-	•	•	•	•	-	54/55

- not yet available □ Sleeve bearings
• Available ■ Ball bearings

Please note that these special versions are not possible for all voltages and speeds, and not in all combinations. The special versions are designed for specific customers and projects. As a rule, they are not available off the shelf and are based on minimum quantities.

Please consult your customer support representative about the feasibility of your special variant.

Axial fans for DC operation

Overview of technically feasible designs

Dimension	VDE, UL, CSA	SWT/EC sleeve bearings / ball bearings	Speed signal	Go / NoGo alarm	Alarm with speed limit	External temperature sensor	Internal temperature sensor	PWM control input	Analog control input	Multi-options control input	Moisture protection	IP >= 54	IP 88	Salt spray protection	Reversible direction of rotation	Page
Axial fans	mm	Series	OPTIONAL												P.	
	□ 119 x 38	4400	ja ■	•	•	•	•	•	•	•	•	•	•	•	•	56/57
	□ 119 x 38	4100 N	ja □/■	•	•	•	•	•	•	•	•	•	•	•	•	58
	<i>S-Force</i> □ 119 x 38	4100 NH..NH6	ja ■	•	•	•	•	•	•	•	•	•	•	•	•	59
	<i>S-Force</i> □ 119 x 38	4100 NH7..NH8	ja ■	•	•	•	•	•	•	•	•	•	•	•	•	60
	□ 119 x 38	DV 4100	ja ■	•	•	•	•	•	•	•	•	•	•	•	•	61
	□ 127 x 38	5200 N	ja ■	•	•	•	•	•	•	•	•	•	•	•	•	62
	□ 127 x 38	DV 5200	ja ■	•	•	•	•	•	•	•	•	•	•	•	•	63
	□ 135 x 38	5100 N	ja ■	•	•	•	•	•	•	•	•	•	•	•	•	64
	<i>S-Force</i> □ 140 x 51	5300	ja ■	•	•	•	•	•	•	•	•	•	•	•	•	65
	<i>S-Force</i> □ 140 x 51	5300 TD	ja ■	•	•	•	•	•	•	•	•	•	•	•	•	66
	∅ 150 x 38	7100 N	ja ■	•	•	•	•	•	•	•	•	•	•	•	•	67
	∅ 150 x 55	7200 N	ja ■	•	•	•	•	•	•	•	•	•	•	•	•	68
	172 x 150 x 51	6400	ja ■	•	•	•	•	•	•	•	•	•	•	•	•	69
	172 x 150 x 51	6400 TD	ja ■	•	•	•	•	•	•	•	•	•	•	•	•	70
	172 x 160 x 51	DV 6400	ja ■	•	•	•	•	•	•	•	•	•	•	•	•	71
	172 x 160 x 51	DV 6400 TD	ja ■	•	•	•	•	•	•	•	•	•	•	•	•	72
	<i>S-Panther</i> 172 x 160 x 51	6300 NTD	ja ■	•	•	•	•	•	•	•	•	•	•	•	•	73
	<i>S-Force</i> 172 x 160 x 51	6300 TD	ja ■	•	•	•	•	•	•	•	•	•	•	•	•	74
	<i>S-Panther</i> ∅ 172 x 51	6300 N	ja ■	•	•	•	•	•	•	•	•	•	•	•	•	75
	<i>S-Panther</i> ∅ 172 x 51	6300 NTD	ja ■	•	•	•	•	•	•	•	•	•	•	•	•	76
	<i>S-Force</i> ∅ 172 x 51	6300	ja ■	•	•	•	•	•	•	•	•	•	•	•	•	77
	<i>S-Force</i> ∅ 172 x 51	6300 TD	ja ■	•	•	•	•	•	•	•	•	•	•	•	•	78
	<i>S-Force</i> ∅ 172 x 51	DV 6300 TD	ja ■	•	•	•	•	•	•	•	•	•	•	•	•	79
	<i>S-Force</i> ∅ 200 x 51	2200 FTD	ja ■	•	•	•	•	•	•	•	•	•	•	•	•	80
	∅ 200 x 51	2200 TD	ja ■	•	•	•	•	•	•	•	•	•	•	•	•	81
	□ 225 x 80	K1G 200	ja ■	•	•	•	•	•	•	•	•	•	•	•	•	82
	□ 225 x 89	K3G 200	ja ■	•	•	•	•	•	•	•	•	•	•	•	•	84

Subject to change

- not yet available
- Sleeve bearings
- Available
- Ball bearings

Please note that these special versions are not possible for all voltages and speeds, and not in all combinations. The special versions are designed for specific customers and projects. As a rule, they are not available off the shelf and are based on minimum quantities.

Please consult your customer support representative about the feasibility of your special variant.

Max. 4.6 m³/h

DC axial fans

□ 25 x 8 mm



- **Material:** Housing: GRP¹⁾ (PBT)
Impeller: GRP¹⁾ (PA)
 - **Direction of air flow:** Exhaust over struts
 - **Direction of rotation:** Counterclockwise, looking towards rotor
 - **Connection:** Via single wires AWG 28, TR 64
 - **Weight:** 5 g
- **Possible special versions:**
(See chapter DC fans - specials)
 - Speed signal
 - Moisture protection

1) Fiberglass-reinforced plastic

Series 250
WVC0025AUBAS

Nominal data

Type	Air flow		Nominal voltage	Voltage range	Sound pressure level	Sound power level	Sinter sleeve bearings Ball bearings	Power consumption	Nominal speed	Temperature range	Service life L ₁₀ (20 °C) ebm-papst standard	Service life L ₁₀ (60 °C) ebm-papst standard	Life expectancy L ₁₀ IPC (40 °C) see page 15	Curve
	m ³ /h	cfm												
255 M	2.3	1.2	5	4.5...5.5	5	< 3	■	0.2	6 500	-10...+70	45 000 / 17 500	47 500	①	
255 N	3.5	1.9	5	4.5...5.5	16	< 3	■	0.4	9 600	-10...+70	40 000 / 15 000	42 500	②	
255 H	4.6	2.6	5	4.5...5.5	23	4.4	■	0.6	12 000	-10...+55	35 000 / 15 000*	37 500	③	
252 N	3.4	1.9	12	10...14	15	< 3	■	0.5	9 000	-10...+70	40 000 / 15 000	42 500	②	
252 H	4.6	2.6	12	10...14	23	4.4	■	0.7	12 000	-10...+55	35 000 / 15 000*	37 500	③	

Subject to change

* at 55 °C

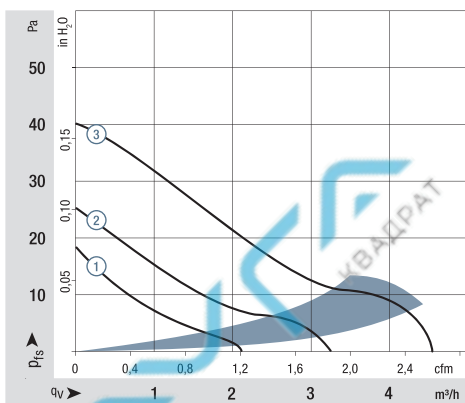

Air performance measured as per: ISO 5801.
Installation category A, without accidental contact.
Noise: Total sound power level L_{WA} ISO 10302 measured on a hemisphere with a radius of 2 m.
Sound pressure level L_{pA} measured at 1 m distance from fan axis.
The values given are applicable only under the specified measuring conditions and may differ depending on the installation conditions.
In the event of deviation from the standard configuration, the parameters must be checked after installation!
For detailed information see <http://www.ebmpapst.com/general-conditions>

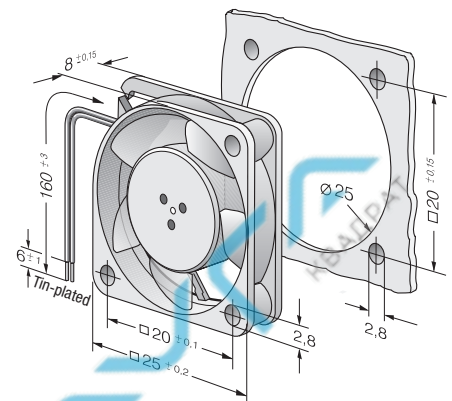

Max. 9 m³/h

DC axial fans

□ 40 x 10 mm



- **Material:** Housing: GRP¹⁾ (PBT)
Impeller: GRP¹⁾ (PA)
 - **Direction of air flow:** Exhaust over struts
 - **Direction of rotation:** Counterclockwise, looking towards rotor
 - **Connection:** Via single wires AWG 28, TR 64
 - **Highlights:** Some models are suitable for use at high ambient temperatures
 - **Weight:** 17 g
- **Possible special versions:** (See chapter DC fans - specials)
 - Speed signal
 - Go / NoGo alarm
 - Moisture protection

1) Fiberglass-reinforced plastic

Series 400 F
WVC0040FUDAS

Nominal data

Type	Air flow		Nominal voltage	Voltage range	Sound pressure level	Sound power level	Sintec sleeve bearings Ball bearings	Power consumption	Nominal speed	Temperature range	Service life L ₁₀ (20 °C) ebm-papst standard	Service life L ₁₀ (60 °C) ebm-papst standard	Life expectancy L ₁₀ IPC (40 °C) see page 15	Curve
	m ³ /h	cfm												
405 F	8	4.7	5	4.5...5.5	22.1	4.4	□	0.7	5 400	-20...+70	45 000 / 17 500	47 500	47 500	②
405 FH	9	5.3	5	4.5...5.5	26.0	4.6	□	0.9	6 000	-20...+70	45 000 / 17 500	47 500	47 500	③
412 FM	6	3.5	12	10...14	17.0	3.8	□	0.5	4 300	-20...+70	45 000 / 17 500	47 500	47 500	①
412 F	8	4.7	12	10...14	22.1	4.4	□	0.7	5 400	-20...+70	45 000 / 17 500	47 500	47 500	②
412 FH	9	5.3	12	10...14	26.0	4.6	□	0.8	6 000	-20...+70	45 000 / 17 500	47 500	47 500	③
414 F	8	4.7	24	20...28	22.1	4.4	□	0.8	5 400	-20...+70	45 000 / 17 500	47 500	47 500	②
414 FH	9	5.3	24	21.6...26.4	26.0	4.4	□	0.9	6 000	-20...+70	45 000 / 17 500	47 500	47 500	③

Model with temperature range up to +85 °C.

412 FM-074	6	3.5	12	10...14	17.0	3.8	□	0.4	4 300	-20...+85	45 000 / 17 500	47 500	47 500	①
412 F-130	8	4.7	12	10...14	22.1	4.4	□	0.6	5 400	-20...+85	45 000 / 17 500	47 500	47 500	②
412 FH-132	9	5.3	12	10...14	26.0	4.6	□	0.8	6 000	-20...+85	45 000 / 17 500	47 500	47 500	③

Subject to change

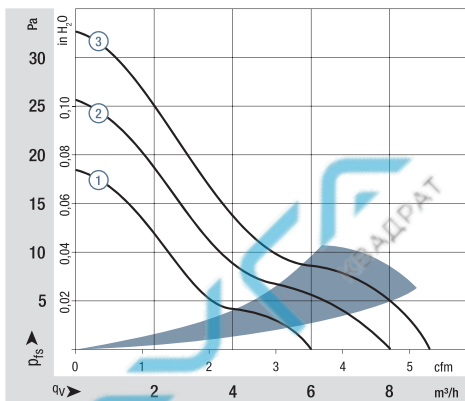

Air performance measured according to: ISO 5801.
Installation category A, without contact protection.
Noise: Total sound power level L_{WA} ISO 10302 measured on a hemisphere with a radius of 2 m.
Sound pressure level L_{pA} measured at 1 m distance from fan axis.
The values given are applicable only under the specified measuring conditions and may differ depending on the installation conditions.
In the event of deviation from the standard configuration, the parameters must be checked after installation!
For detailed information see <http://www.ebmpapst.com/general-conditions>

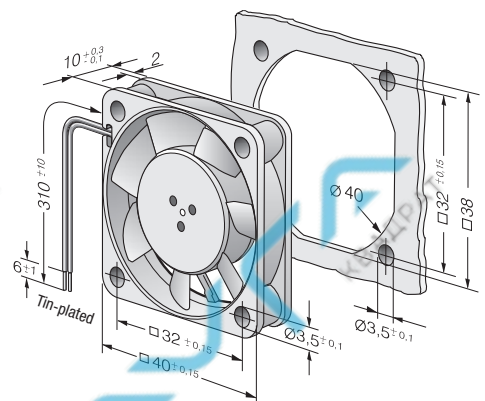

Max. 13.5 m³/h

DC axial fans

□ 40 x 20 mm

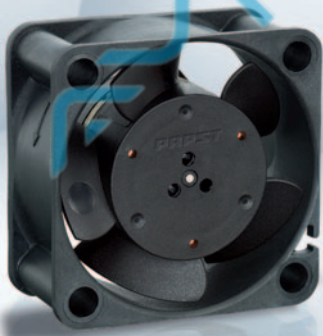

- **Material:** Housing: GRP¹⁾ (PBT)
Impeller: GRP¹⁾ (PA)
 - **Direction of air flow:** Exhaust over struts
 - **Direction of rotation:** Counterclockwise, looking towards rotor
 - **Connection:** Via single wires AWG 28, TR 64
 - **Highlights:** Some models are suitable for use at high ambient temperatures
 - **Weight:** 27 g
- **Possible special versions:** (See chapter DC fans - specials)
 - Speed signal
 - Go / NoGo alarm
 - PWM control input
 - Moisture protection

1) Fiberglass-reinforced plastic

Series 400
WVC0040YUDBS

Nominal data

Type	Air flow		Nominal voltage	Voltage range	Sound pressure level	Sound power level	Sinter sleeve bearings Ball bearings	Power consumption	Nominal speed	Temperature range	Service life L ₁₀ (20 °C) ebm-papst standard	Service life L ₁₀ (60 °C) ebm-papst standard	Life expectancy L ₁₀ (IPC (40 °C) see page 15	Curve
	m ³ /h	cfm												
405	10.0	5.9	5	4.5...5.5	18	3.8	■	0.9	6 000	-20...+70	50 000 / 20 000	52 500	52 500	①
412	10.0	5.9	12	10...14	18	3.8	■	0.8	6 000	-20...+70	50 000 / 20 000	52 500	52 500	①
412 H	13.5	7.9	12	10...14	29	4.7	■	1.6	8 100	-20...+60	45 000 / 17 500	47 500	47 500	②
414	10.0	5.9	24	20...28	18	3.8	■	1.0	6 000	-20...+70	50 000 / 20 000	52 500	52 500	①
414 H	13.5	7.9	24	20...26.5	29	4.7	■	1.7	8 100	-20...+60	45 000 / 17 500	47 500	47 500	②
Model with temperature range up to +85 °C.														
412-099	10.0	5.9	12	10...14	18	3.8	■	0.8	6 000	-20...+85	50 000 / 20 000	52 500	52 500	①
Subject to change														

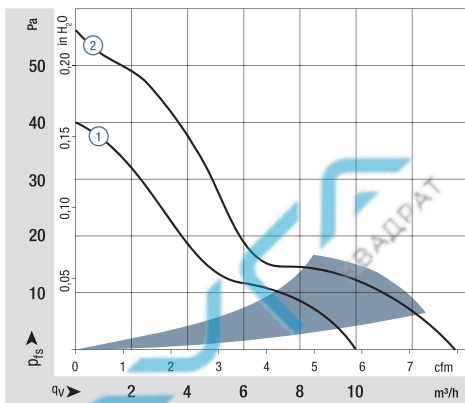

Air performance measured according to: ISO 5801.
Installation category A, without contact protection.
Noise: Total sound power level L_{WA} ISO 10302 measured on a hemisphere with a radius of 2 m.
Sound pressure level L_{pA} measured at 1 m distance from fan axis.
The values given are applicable only under the specified measuring conditions and may differ depending on the installation conditions.
In the event of deviation from the standard configuration, the parameters must be checked after installation!
For detailed information see <http://www.ebmpapst.com/general conditions>

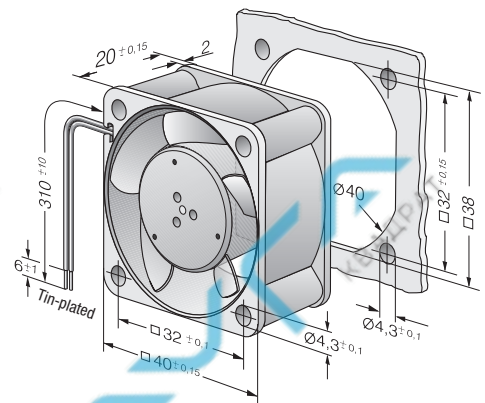

Max. 38 m³/h

DC axial fans

□ 40 x 28 mm



- **Material:** Housing: GRP¹⁾ (PBT)
Impeller: GRP¹⁾ (PA)
 - **Direction of air flow:** Exhaust over struts
 - **Direction of rotation:** Counterclockwise, looking towards rotor
 - **Connection:** Via single wires AWG 28, UL 1061
 - **Weight:** 45 g
- **Possible special versions:** (See chapter DC fans - specials)
 - Speed signal
 - Go / NoGo alarm
 - Alarm with speed limit
 - External temperature sensor
 - PWM control input
 - Analog control input
 - Moisture protection
 - Salt spray protection
 - Degree of protection IP 54 / IP 68

1) Fiberglass-reinforced plastic

Series 420 J
WVC0040JUDBS

Nominal data

Type	Air flow		Nominal voltage	Voltage range	Sound pressure level	Sound power level	Sinter sleeve bearings Ball bearings	Power consumption	Nominal speed	Temperature range	Service life L ₁₀ (40 °C) ebm-papst standard	Service life L ₁₀ (T _{max}) ebm-papst standard	Life expectancy L ₁₀ IPC (40 °C) see page 15	Curve
	m³/h	cfm												
422 JM	24	14,2	12	8...13,8	42	5,5	■	2,4	11 400	-20...+70	75 000 / 37 500	127 500	127 500	①
422 JN	31	18,3	12	8...13,8	48	6,0	■	4,1	14 250	-20...+70	67 500 / 35 000	115 000	115 000	②
422 JH	38	22,4	12	8...13,8	54	6,6	■	6,9	17 250	-20...+70	60 000 / 30 000	102 500	102 500	③
424 JM	24	14,2	24	16...28	42	5,5	■	2,7	11 400	-20...+70	75 000 / 37 500	127 500	127 500	①
424 JN	31	18,3	24	16...28	48	6,0	■	4,3	14 250	-20...+70	67 500 / 35 000	115 000	115 000	②
424 JH	38	22,4	24	16...26,4	54	6,6	■	6,9	17 250	-20...+65	60 000 / 32 500	102 500	102 500	③
Model with degree of protection IP 68, -40 °C, speed signal and EMC - Class B.														
422 J/2 HPU	37	21,8	12	8...13,8	56	6,6	■	7,5	17 250	-40...+70	60 000 / 30 000	102 500	102 500	④
424 J/2 HPU	37	21,8	24	18...28	56	6,6	■	7,0	17 250	-40...+70	60 000 / 30 000	102 500	102 500	④
428 J/2 HPU	37	21,8	48	36...60	56	6,6	■	7,0	17 250	-40...+70	60 000 / 30 000	102 500	102 500	④

Subject to change

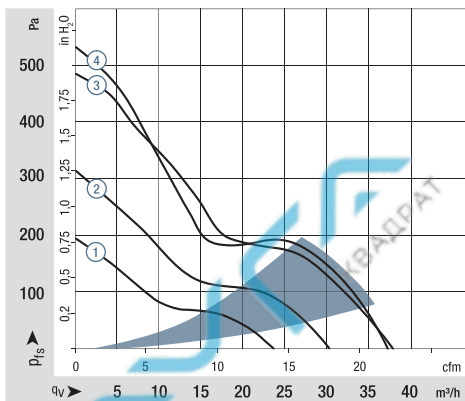

Air performance measured according to: ISO 5801.
Installation category A, without contact protection.
Noise: Total sound power level L_{WA} ISO 10302 measured on a hemisphere with a radius of 2 m.
Sound pressure level L_{pA} measured at 1 m distance from fan axis.
The values given are applicable only under the specified measuring conditions and may differ depending on the installation conditions.
In the event of deviation from the standard configuration, the parameters must be checked after installation!
For detailed information see <http://www.ebmpapst.com/general-conditions>

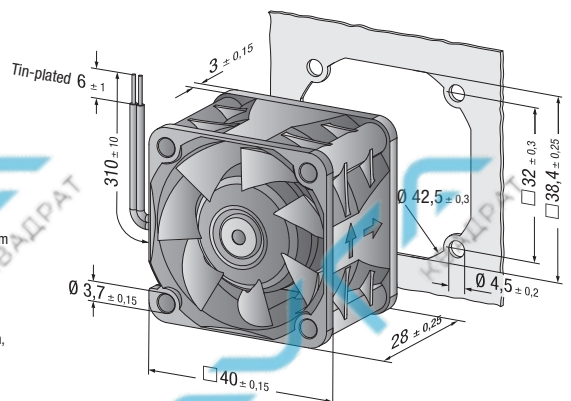

Max. 20 m³/h

DC axial fans

□ 50 x 15 mm



- **Material:** Housing: GRP¹⁾ (PBT)
Impeller: GRP¹⁾ (PA)
 - **Direction of air flow:** Exhaust over struts
 - **Direction of rotation:** Counterclockwise, looking towards rotor
 - **Connection:** Via single wires AWG 28, TR 64
 - **Highlights:** Some models are suitable for use at high ambient temperatures
 - **Weight:** 27 g
- **Possible special versions:** (See chapter DC fans - specials)
 - Speed signal
 - Go / NoGo alarm
 - PWM control input
 - Moisture protection

1) Fiberglass-reinforced plastic

Series 500 F
WVC0050FUDBS

Nominal data

Type	Air flow		Nominal voltage	Voltage range	Sound pressure level	Sound power level	Sinter sleeve bearings Ball bearings	Power consumption	Nominal speed	Temperature range	Service life L ₁₀ (20 °C) ebm-papst standard	Service life L ₁₀ (60 °C) ebm-papst standard	Life expectancy L ₁₀ (IPC (40 °C) see page 15	Curve
	m ³ /h	cfm												
512 F	20	11.8	12	10.8...13.2	30	4.5	■	0.8	5 000	-20...+70	50 000 / 20 000	52 500	52 500	②
514 F	20	11.8	24	21.6...26.4	30	4.5	■	0.9	5 000	-20...+70	50 000 / 20 000	52 500	52 500	②
Model with temperature range up to +85 °C.														
512 FL-547	11	6.5	12	10.2...13.8	18	3.7	■	0.4	3 000	-20...+85	50 000 / 20 000	52 500	52 500	①
512 F-532	20	11.8	12	10.8...13.2	30	4.5	■	0.9	5 000	-20...+85	50 000 / 20 000	52 500	52 500	②

Subject to change

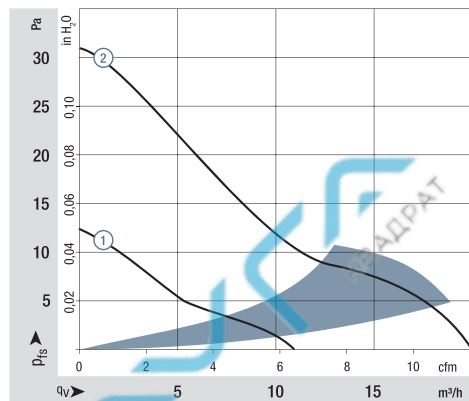

Air performance measured according to: ISO 5801.
Installation category A, without contact protection.
Noise: Total sound power level L_{WA} ISO 10302 measured on a hemisphere with a radius of 2 m.
Sound pressure level L_{pA} measured at 1 m distance from fan axis.
The values given are applicable only under the specified measuring conditions and may differ depending on the installation conditions.
In the event of deviation from the standard configuration, the parameters must be checked after installation!
For detailed information see <http://www.ebmpapst.com/general-conditions>

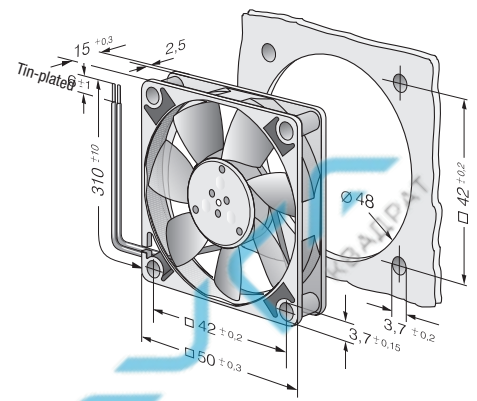

Max. 33 m³/h

DC axial fans

□ 60 x 15 mm



- **Material:** Housing: GRP¹⁾ (PBT)
Impeller: GRP¹⁾ (PA)
 - **Direction of air flow:** Exhaust over struts
 - **Direction of rotation:** Counterclockwise, looking towards rotor
 - **Connection:** Via single wires AWG 28, TR 64
 - **Highlights:** Some models are suitable for use at high ambient temperatures
 - **Weight:** 30 g
- **Possible special versions:** (See chapter DC fans - specials)
 - Speed signal
 - Go / NoGo alarm
 - PWM control input
 - Moisture protection

1) Fiberglass-reinforced plastic

Series 600 F
WVC0060FUDBS

Nominal data

Type	Air flow		Nominal voltage	Voltage range	Sound pressure level	Sound power level	Sintec sleeve bearings Ball bearings	Power consumption	Nominal speed	Temperature range	Service life L ₁₀ (20 °C) ebm-papst standard	Service life L ₁₀ (60 °C) ebm-papst standard	Life expectancy L ₁₀ IPC (40 °C) see page 15	Curve
	m ³ /h	cfm												
605 F	29	17.1	5	4.5...5.2	27	4.4	□	1.1	4 000	-20...+50	50 000 / 20 000	52 500	52 500	②
612 FL	19	11.2	12	11.5...13.2	16	3.6	□	0.4	2 650	-20...+70	50 000 / 20 000	52 500	52 500	①
612 F	29	17.1	12	10.8...13.2	27	4.4	□	1.0	3 900	-20...+70	50 000 / 20 000	52 500	52 500	②
612 FH	33	19.4	12	10.0...13.2	31	4.8	□	1.5	4 500	-20...+60	45 000 / 17 500	47 500	47 500	③
614 F	29	17.1	24	21.6...26.4	27	4.4	□	1.1	3 900	-20...+70	50 000 / 20 000	52 500	52 500	②
614 F/39 H-691	33	19.4	24	16...28	31	4.8	□	1.4	4 500	-20...+60	45 000 / 17 500	47 500	47 500	③

Model with temperature range up to +80 / 85 °C.

612 FL-680	19	11.2	12	11.5...14	16	3.6	□	0.5	2 650	-20...+85	50 000 / 20 000	52 500	52 500	①
612 F-637	29	17.1	12	10.8...12.6	27	4.4	□	1.0	3 900	-20...+80	50 000 / 20 000	52 500	52 500	②

Subject to change

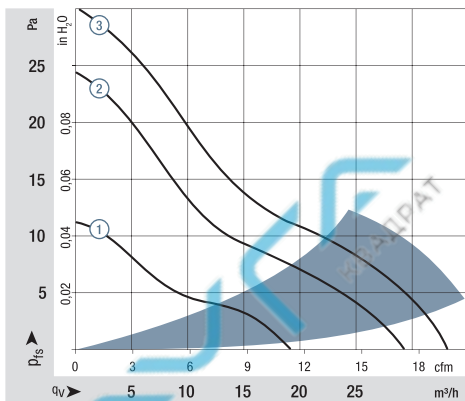

Air performance measured according to: ISO 5801.
Installation category A, without contact protection.
Noise: Total sound power level L_{WA} ISO 10302 measured on a hemisphere with a radius of 2 m.
Sound pressure level L_{pA} measured at 1 m distance from fan axis.
The values given are applicable only under the specified measuring conditions and may differ depending on the installation conditions.
In the event of deviation from the standard configuration, the parameters must be checked after installation!
For detailed information see <http://www.ebmpapst.com/general-conditions>

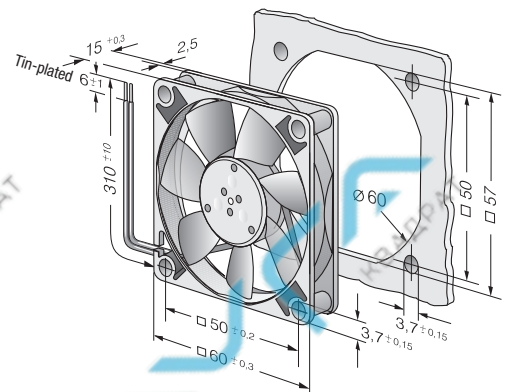

Max. 67 m³/h

DC axial fans

□ 60 x 25 mm



- **Material:** Housing: GRP¹⁾ (PBT)
Impeller: GRP¹⁾ (PA)
 - **Direction of air flow:** Exhaust over struts
 - **Direction of rotation:** Clockwise, looking towards rotor
 - **Connection:** Via single wires AWG 22, TR 64
 - **Highlights:** Very low-noise motor
 - **Weight:** 70 g
- **Possible special versions:** (See chapter DC fans - specials)
 - Speed signal
 - Go / NoGo alarm
 - Alarm with speed limit
 - External temperature sensor
 - Internal temperature sensor
 - PWM control input
 - Analog control input
 - Moisture protection

1) Fiberglass-reinforced plastic

Series 620
VWC0060AUEBS

Nominal data

Type	Air flow		Nominal voltage	Voltage range	Sound pressure level	Sound power level	Sinter sleeve bearings Ball bearings	Power consumption	Nominal speed	Temperature range	Service life L ₁₀ (40 °C) ebm-papst standard	Service life L ₁₀ (T _{max}) ebm-papst standard	Life expectancy L ₁₀ (IPC (40 °C) see page 15	Curve
	m ³ /h	cfm												
622 L	21	12.4	12	8...15	20	3.7	■	0.5	3 200	-20...+85	80 000 / 20 000	135 000	①	
622 M	30	17.7	12	8...15	29	4.3	■	1.0	4 550	-20...+75	77 500 / 30 000	130 000	②	
622 N	40	23.5	12	8...15	35	4.7	■	1.9	6 100	-20...+70	72 500 / 35 000	122 500	③	
622 H	46	27.1	12	8...15	39	5.1	■	2.3	6 850	-20...+70	70 000 / 35 000	117 500	④	
622 HH	56	33.0	12	8...15	43	5.6	■	3.5	8 200	-20...+70	65 000 / 32 500	110 000	⑤	
622/2 H3P	67	39.4	12	8...15	48	5.9	■	5.5	9 700	-20...+70	52 500 / 32 500	87 500	⑥	
624 L	21	12.4	24	18...28	20	3.7	■	1.0	3 200	-20...+70	80 000 / 40 000	135 000	①	
624 M	30	17.7	24	12...28	29	4.3	■	1.5	4 550	-20...+70	77 500 / 37 500	130 000	②	
624 N	40	23.5	24	12...28	35	4.7	■	2.2	6 100	-20...+70	72 500 / 35 000	122 500	③	
624 H	46	27.1	24	18...28	39	5.1	■	2.4	6 850	-20...+70	70 000 / 35 000	117 500	④	
624 HH	56	33.0	24	18...28	43	5.6	■	3.6	8 200	-20...+70	65 000 / 32 500	110 000	⑤	
624/2 H3P	67	39.4	24	18...28	48	5.9	■	5.6	9 700	-20...+60	52 500 / 32 500	87 500	⑥	
628 HH	56	33.0	48	36...60	43	5.6	■	4.2	8 200	-20...+70	65 000 / 32 500	110 000	⑤	

Subject to change

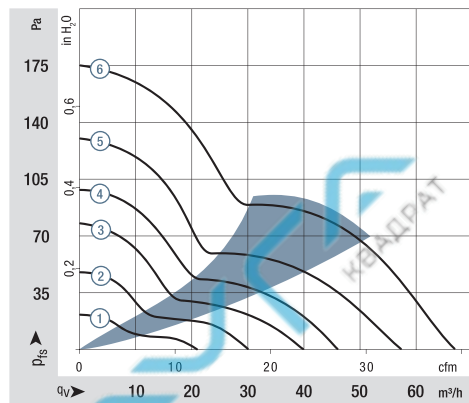

Air performance measured according to: ISO 5801.
Installation category A, without contact protection.
Noise: Total sound power level L_{WA} ISO 10302 measured on a hemisphere with a radius of 2 m.
Sound pressure level L_{pA} measured at 1 m distance from fan axis.
The values given are applicable only under the specified measuring conditions and may differ depending on the installation conditions.
In the event of deviation from the standard configuration, the parameters must be checked after installation!
For detailed information see <http://www.ebmpapst.com/general-conditions>

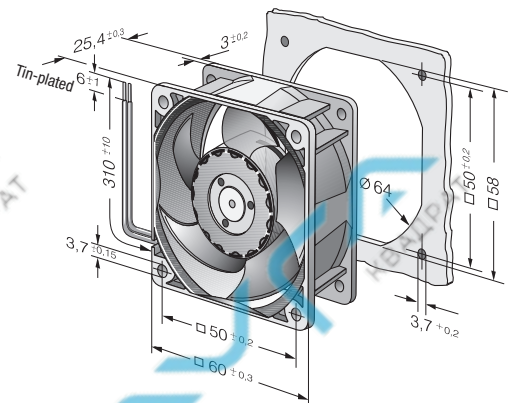

Max. 58 m³/h

DC axial fans

□ 60 x 25 mm



- **Material:** Housing: GRP¹⁾ (PBT)
Impeller: GRP¹⁾ (PA)
 - **Direction of air flow:** Exhaust over struts
 - **Direction of rotation:** Clockwise, looking towards rotor
 - **Connection:** Via single wires AWG 22, TR 64
 - **Highlights:** Developed for applications with demanding environmental requirements
 - **Weight:** 70 g
- **Possible special versions:** (See chapter DC fans - specials)
 - Speed signal
 - Go / NoGo alarm
 - Alarm with speed limit
 - External temperature sensor
 - PWM control input
 - Analog control input
 - Moisture protection
 - Salt spray protection
 - Degree of protection: IP 54 / IP 68

1) Fiberglass-reinforced plastic

Series 630
VWC0060AU EBS

Nominal data

Type	Air flow		Nominal voltage	Voltage range	Sound pressure level	Sound power level	Sintec sleeve bearings Ball bearings	Power consumption	Nominal speed	Temperature range	Service life L ₁₀ (40 °C) ebm-papst standard	Service life L ₁₀ (T _{max}) ebm-papst standard	Life expectancy L ₁₀ (IPC (40 °C) see page 15	Curve
	m ³ /h	cfm												
632 NU	40	23.5	12	6...15	33	5.2	■	1.8	5 900	-20...+70	85 000 / 42 500	142 500	①	
632/2 HPU	44	25.9	12	10.8...13.2	35	5.4	■	1.5	6 300	-20...+70	85 000 / 42 500	142 500	②	
634 NU	40	23.5	24	12...30	34	5.1	■	1.6	5 900	-20...+70	85 000 / 42 500	142 500	①	
634 HHU	58	34.1	24	18...28	44	6.1	■	3.2	8 500	-20...+70	75 000 / 37 500	127 500	③	
634/2 HHPU	58	34.1	24	18...28	44	6.1	■	3.2	8 500	-40...+70	75 000 / 37 500	127 500	③	
638/2 HPU	44	25.9	48	40...60	35	5.4	■	1.8	6 300	-20...+70	85 000 / 42 500	142 500	②	
638/2 HHPU	58	34.1	48	40...60	44	6.1	■	3.2	8 500	-40...+70	75 000 / 37 500	127 500	③	

Subject to change

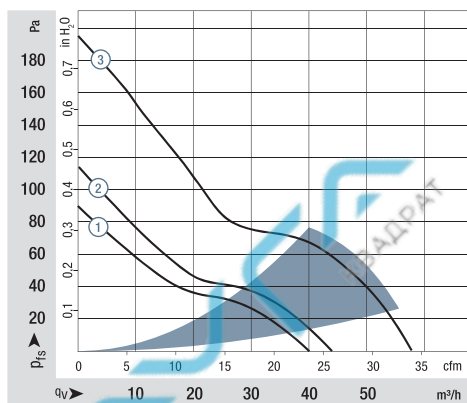

Air performance measured according to: ISO 5801.
Installation category A, without contact protection.
Noise: Total sound power level L_{WA} ISO 10302 measured on a hemisphere with a radius of 2 m.
Sound pressure level L_{pA} measured at 1 m distance from fan axis.
The values given are applicable only under the specified measuring conditions and may differ depending on the installation conditions.
In the event of deviation from the standard configuration, the parameters must be checked after installation!
For detailed information see <http://www.ebmpapst.com/general conditions>

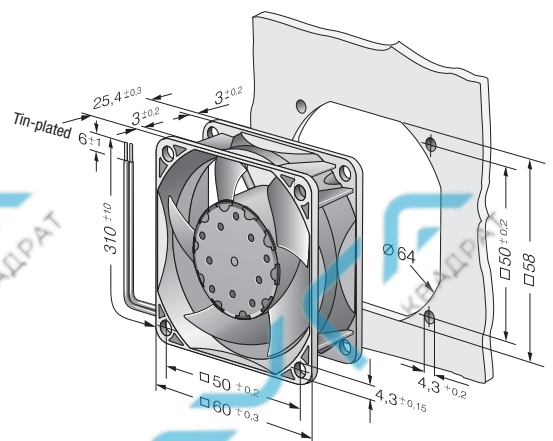

Max. 56 m³/h

DC axial fans

□ 60 x 25 mm



- **Material:** Housing: GRP¹⁾ (PBT)
Impeller: GRP¹⁾ (PA)
 - **Direction of air flow:** Exhaust over struts
 - **Direction of rotation:** Clockwise, looking towards rotor
 - **Connection:** Via single wires AWG 22, TR 64
 - **Highlights:** Some models are suitable for use at high ambient temperatures up to 85 °C.
 - **Weight:** 66 g
- **Possible special versions:** (See chapter DC fans - specials)
 - Speed signal
 - Go / NoGo alarm
 - Moisture protection
 - Degree of protection: IP 54 / IP 68

1) Fiberglass-reinforced plastic

Series 600 N
WVC0060YUEBS

Nominal data

Type	Air flow		Nominal voltage	Voltage range	Sound pressure level	Sound power level	Sinter sleeve bearings Ball bearings	Power consumption	Nominal speed	Temperature range	Service life L ₁₀ (40 °C) ebm-papst standard	Service life L ₁₀ (T _{max}) ebm-papst standard	Life expectancy L ₁₀ (IPC (40 °C) see page 15	Curve
	m ³ /h	cfm												
612 NGLE	21	12.4	12	8...15	16	3.6	■	0.6	2 500	-20...+85	80 000 / 27 500	135 000	①	
612 NLE	21	12.4	12	8...15	16	3.6	■	0.4	2 500	-20...+85	80 000 / 27 500	135 000	①	
612 NGMLE	25	14.7	12	8...15	19	3.9	■	0.7	3 000	-20...+80	80 000 / 32 500	135 000	②	
612 NMLE	25	14.7	12	8...15	19	3.9	■	0.4	3 000	-20...+85	80 000 / 27 500	135 000	②	
612 NGME	35	20.6	12	8...15	28	4.6	■	1.2	4 100	-20...+75	80 000 / 35 000	135 000	③	
612 NME	35	20.6	12	8...15	28	4.6	■	0.8	4 100	-20...+75	80 000 / 35 000	135 000	③	
612 NN	40	23.5	12	8...15	35	5.0	■	1.5	5 100	-20...+70	70 000 / 35 000	117 500	④	
612 NH	43	25.3	12	8...15	37	5.3	■	1.8	5 600	-20...+70	70 000 / 35 000	117 500	⑤	
612 NHH-118	56	33.0	12	8...15	41	5.7	■	2.9	6 800	-20...+70	60 000 / 30 000	102 500	⑥	
614 NGL	21	12.4	24	18...28	16	3.6	■	1.0	2 500	-20...+70	80 000 / 40 000	135 000	①	
614 NL	21	12.4	24	18...28	16	3.6	■	0.8	2 500	-20...+70	80 000 / 40 000	135 000	①	
614 NGML	25	14.7	24	18...28	19	3.9	■	1.2	3 000	-20...+70	80 000 / 40 000	135 000	②	
614 NML	25	14.7	24	18...28	19	3.9	■	1.0	3 000	-20...+70	80 000 / 40 000	135 000	②	
614 NGM	35	20.6	24	18...28	28	4.6	■	1.7	4 100	-20...+70	80 000 / 40 000	135 000	③	
614 NM	35	20.6	24	18...28	28	4.6	■	1.3	4 100	-20...+70	80 000 / 40 000	135 000	③	
614 NN	40	23.5	24	18...28	35	5.0	■	1.8	5 100	-20...+70	70 000 / 35 000	117 500	④	
614 NH	43	25.3	24	18...26	37	5.3	■	2.1	5 600	-20...+70	70 000 / 35 000	117 500	⑤	
614 NHH	56	33.0	24	18...26	41	5.7	■	2.9	6 850	-20...+70	60 000 / 30 000	102 500	⑥	
614 NHH-119	56	33.0	24	18...28	41	5.7	■	2.9	6 850	-20...+70	60 000 / 30 000	102 500	⑥	
618 NM	35	20.6	48	36...56	28	4.6	■	1.9	4 100	-20...+70	80 000 / 40 000	135 000	③	
618 NN	40	23.5	48	36...56	35	5.0	■	2.1	5 100	-20...+65	70 000 / 40 000	117 500	④	

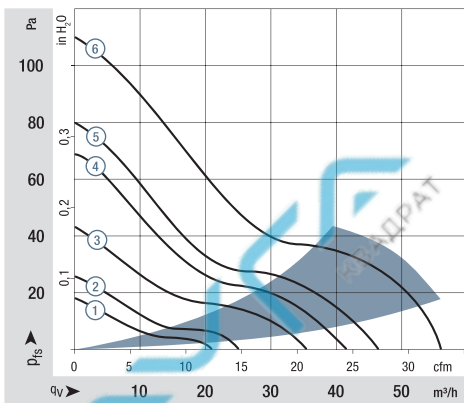

Air performance measured according to: ISO 5801.
Installation category A, without contact protection.
Noise: Total sound power level L_{WA} ISO 10302 measured on a hemisphere with a radius of 2 m.
Sound pressure level L_{pA} measured at 1 m distance from fan axis.
The values given are applicable only under the specified measuring conditions and may differ depending on the installation conditions.
In the event of deviation from the standard configuration, the parameters must be checked after installation!
For detailed information see <http://www.ebmpapst.com/general-conditions>

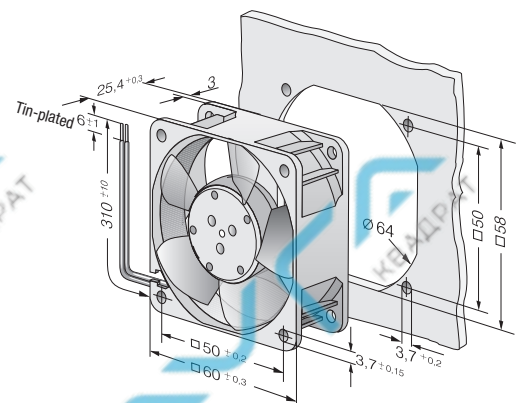

Max. 82 m³/h

DC axial fans

□ 60 x 32 mm



- **Material:** Housing: GRP¹⁾ (PBT)
Impeller: GRP¹⁾ (PA)
 - **Direction of air flow:** Exhaust over struts
 - **Direction of rotation:** Clockwise, looking towards rotor
 - **Connection:** Via single wires AWG 24, TR 64
 - **Weight:** 100 g
- **Possible special versions:** (See chapter DC fans - specials)
 - Speed signal
 - Go / NoGo alarm
 - Alarm with speed limit
 - External temperature sensor
 - PWM control input
 - Analog control input
 - Moisture protection

1) Fiberglass-reinforced plastic

Series 600 J
WVC0060JUECS

Nominal data

Type	Air flow		Nominal voltage	Voltage range	Sound pressure level	Sound power level	Sinter sleeve bearings Ball bearings	Power consumption	Nominal speed	Temperature range	Service life L ₁₀ (40 °C) ebm-papst standard	Service life L ₁₀ (T _{max}) ebm-papst standard	Life expectancy L ₁₀ (IPC (40 °C) see page 15	Curve
	m ³ /h	cfm												
612 JH	70	41.2	12	7...13.6	53	6.4	■	7.7	11 700	-20...+70	57 500 / 27 500	97 500	97 500	①
614 JH	70	41.2	24	14...26.4	53	6.4	■	7.7	11 700	-20...+70	57 500 / 27 500	97 500	97 500	①
618 JH	70	41.2	48	36...56	53	6.4	■	7.7	11 700	-20...+70	57 500 / 27 500	97 500	97 500	①
Fan types with streamer and integrated guard grille.														
614 J/2 HHP	82	48.3	24	18...30	62	7.6	■	14.6	15 000	-20...+75	65 000 / 25 000	110 000	110 000	②
618 J/2 HHP	82	48.3	48	38...58	62	7.6	■	14.6	15 000	-20...+75	65 000 / 25 000	110 000	110 000	②

Subject to change

Rear view of types 614 J/2 HHP and 618 J/2 HHP

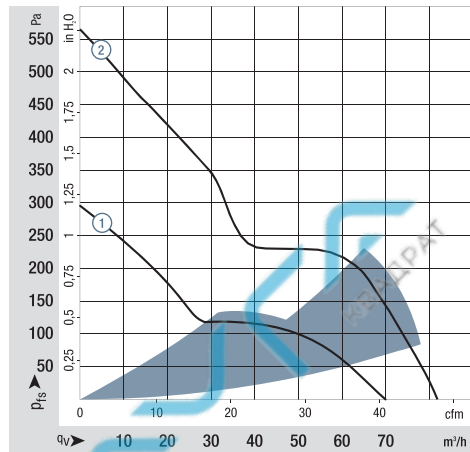
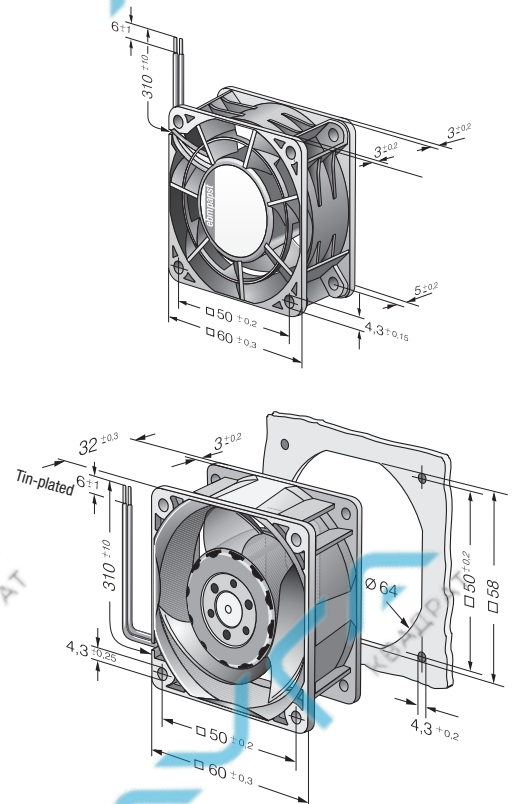

Air performance measured according to: ISO 5801.
Installation category A, without contact protection.
Noise: Total sound power level L_{WA} ISO 10302 measured on a hemisphere with a radius of 2 m.
Sound pressure level L_{PA} measured at 1 m distance from fan axis.
The values given are applicable only under the specified measuring conditions and may differ depending on the installation conditions.
In the event of deviation from the standard configuration, the parameters must be checked after installation!
For detailed information see <http://www.ebmpapst.com/general-conditions>

Max. 44 m³/h

DC axial fans

□ 70 x 15 mm



- **Material:** Housing: GRP¹⁾ (PBT)
Impeller: GRP¹⁾ (PA)
 - **Direction of air flow:** Exhaust over struts
 - **Direction of rotation:** Counterclockwise, looking towards rotor
 - **Connection:** Via single wires AWG 24 to AWG 28, TR 64
 - **Weight:** 53 g
- **Possible special versions:** (See chapter DC fans - specials)
 - Speed signal
 - Go / NoGo alarm
 - Moisture protection

1) Fiberglass-reinforced plastic

Series 700 F
WVC0070FUEAS

Nominal data

Type	Air flow		Nominal voltage	Voltage range	Sound pressure level	Sound power level	Sintec sleeve bearings Ball bearings	Power consumption	Nominal speed	Temperature range	Service life L ₁₀ (40 °C) ebm-papst standard	Service life L ₁₀ (T _{max}) ebm-papst standard	Life expectancy L ₁₀ IPC (40 °C) see page 15	Curve
	m ³ /h	cfm												
712 F/2L-005*	28	16.5	12	8...13.8	25	4.7	□	0.6	3 300	-20...+70	60 000 / 30 000	102 500	102 500	①
712 F/2M-006*	36	21.2	12	8...13.8	32	5.0	□	1.1	4 300	-20...+70	60 000 / 30 000	102 500	102 500	②
712 F	44	25.9	12	8...13.8	38	5.3	□	1.7	5 300	-20...+70	60 000 / 30 000	102 500	102 500	③
714 F	44	25.9	24	18...28	38	5.3	□	1.5	5 300	-20...+70	60 000 / 30 000	102 500	102 500	③

Subject to change

*Version with 3-pin Molex plug housing Molex Contacts 22-01-2035 08-50-0113

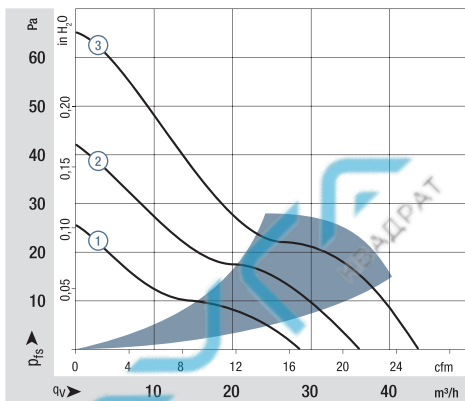

Air performance measured according to: ISO 5801. Installation category A, without contact protection.
Noise: Total sound power level L_w ISO 10302 measured on a hemisphere with a radius of 2 m.
Sound pressure level L_pA measured at 1 m distance from fan axis.
The values given are applicable only under the specified measuring conditions and may differ depending on the installation conditions.
In the event of deviation from the standard configuration, the parameters must be checked after installation!
For detailed information see <http://www.ebmpapst.com/general-conditions>

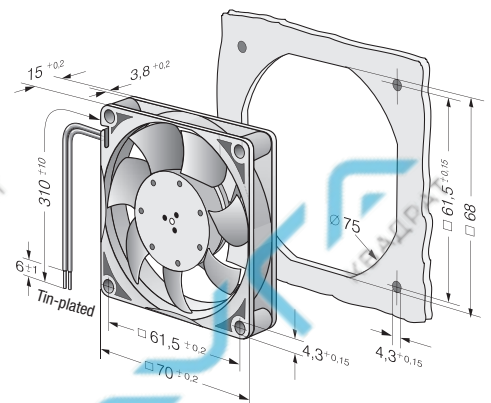

Max. 117 m³/h

DC axial fans

□ 80 x 25 mm



- **Material:** Housing: GRP¹⁾ (PBT)
Impeller: GRP¹⁾ (PA)
 - **Direction of air flow:** Exhaust over struts
 - **Direction of rotation:** Counterclockwise, looking towards rotor
 - **Connection:** Via single wires AWG 24, TR 64
 - **Highlights:** Very low-noise motor
 - **Weight:** 105 g
- **Possible special versions:** (See chapter DC fans - specials)
 - Speed signal
 - Go / NoGo alarm
 - Alarm with speed limit
 - External temperature sensor
 - Internal temperature sensor
 - PWM control input
 - Analog control input
 - Moisture protection

1) Fiberglass-reinforced plastic

Series 8450
WVC0080AUEBS

Nominal data

Type	Air flow		Nominal voltage	Voltage range	Sound pressure level	Sound power level	Sinter sleeve bearings Ball bearings	Power consumption	Nominal speed	Temperature range	Service life L ₁₀ (40 °C) ebm-papst standard	Service life L ₁₀ (T _{max}) ebm-papst standard	Life expectancy L ₁₀ (IPC (40 °C) see page 15	Curve
	m ³ /h	cfm												
8452/2 L	32	18.8	12	8...15	14	3.3	■	0.4	1 700	-20...75	80 000 / 35 000	135 000	135 000	①
8452 M	58	34.1	12	8...15	32	4.7	■	1.3	3 100	-20...75	80 000 / 35 000	135 000	135 000	②
8452/2 N	68	40.0	12	8...15	36	5.0	■	1.8	3 600	-20...70	70 000 / 35 000	117 500	117 500	③
Models with 25 kHz PWM control and speed signal to 4-wire specification.														
8452/2 HP	75	44.1	12	10.8...13.2	38	5.3	■	2.5	4 000	-20...70	70 000 / 35 000	117 500	117 500	④
8452/2 HHP	83	48.8	12	10.8...13.2	42	5.5	■	3.5	4 400	-20...60	65 000 / 40 000	110 000	110 000	⑤
Models with 1-30 kHz PWM control and speed signal.														
8452/2 H4P	117	68.8	12	8...15	50	6.4	■	6.8	6 200	-20...70	60 000 / 30 000	102 500	102 500	⑥
8454/2 H4P	117	68.8	24	20.0...26.4	50	6.4	■	6.8	6 200	-20...70	60 000 / 30 000	102 500	102 500	⑥

Subject to change

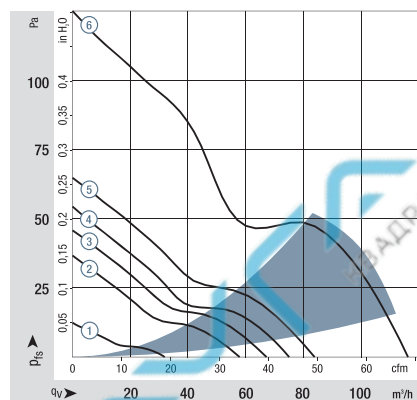

Air performance measured according to: ISO 5801.
Installation category A, without contact protection.
Noise: Total sound power level L_{WA} ISO 10302 measured on a hemisphere with a radius of 2 m.
Sound pressure level L_{pA} measured at 1 m distance from fan axis.
The values given are applicable only under the specified measuring conditions and may differ depending on the installation conditions.
In the event of deviation from the standard configuration, the parameters must be checked after installation!
For detailed information see <http://www.ebmpapst.com/general conditions>

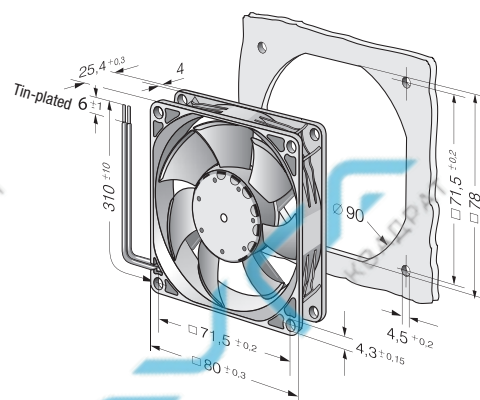

Max. 79 m³/h

DC axial fans

□ 80 x 25 mm



- **Material:** Housing: GRP¹⁾ (PBT)
Impeller: GRP¹⁾ (PA)
 - **Direction of air flow:** Exhaust over struts
 - **Direction of rotation:** Counterclockwise, looking towards rotor
 - **Connection:** Via single wires AWG 24, TR 64
 - **Highlights:** Some models are suitable for use at high ambient temperatures up to 85 °C.
 - **Weight:** 95 g
- **Possible special versions:** (See chapter DC fans - specials)
 - Speed signal
 - Go / NoGo alarm
 - Alarm with speed limit
 - External temperature sensor
 - Internal temperature sensor
 - PWM control input
 - Analog control input
 - Moisture protection
 - Degree of protection: IP 54 / IP 68

1) Fiberglass-reinforced plastic

Series 8400 N
WVC0080YUEBS

Nominal data

Type	Air flow		Nominal voltage	Voltage range	Sound pressure level	Sound power level	Sintec sleeve bearings Ball bearings	Power consumption	Nominal speed	Temperature range	Service life L ₁₀ (40 °C) ebm-papst standard	Service life L ₁₀ (T _{max}) ebm-papst standard	Life expectancy L ₁₀ (IPC (40 °C) see page 15	Curve
	m ³ /h	cfm												
8412 NGL	33	19.4	12	8...15	12	3.5	□	0.5	1 500	-20...+85	80 000 / 27 500	135 000	①	
8412 NLE	33	19.4	12	8...15	17	3.7	■	0.3	1 500	-20...+85	80 000 / 27 500	135 000	①	
8412 NGMLE	45	26.5	12	8...15	19	3.9	□	0.9	2 050	-20...+80	80 000 / 32 500	135 000	②	
8412 NMLE	45	26.5	12	8...15	21	4.0	■	0.6	2 050	-20...+85	80 000 / 27 500	135 000	②	
8412 NGME	58	34.1	12	8...15	26	4.3	□	1.4	2 600	-20...+75	80 000 / 35 000	135 000	③	
8412 NME	58	34.1	12	8...15	27	4.4	■	1.0	2 600	-20...+75	80 000 / 35 000	135 000	③	
8412 NG	69	40.6	12	8...15	32	4.7	□	2.0	3 100	-20...+70	70 000 / 35 000	117 500	④	
8412 N	69	40.6	12	8...15	32	4.7	■	1.7	3 100	-20...+70	70 000 / 35 000	117 500	④	
8412 NH	79	46.5	12	8...13.2	37	5.0	■	2.1	3 600	-20...+70	70 000 / 35 000	117 500	⑤	
8412 NH-217	79	46.5	12	8...15	37	5.0	■	2.5	3 600	-20...+70	70 000 / 35 000	117 500	⑤	
8414 NGL	33	19.4	24	18...28	12	3.5	□	0.9	1 500	-20...+70	80 000 / 40 000	135 000	①	
8414 NL	33	19.4	24	18...28	17	3.7	■	0.8	1 500	-20...+70	80 000 / 40 000	135 000	①	
8414 NGML	45	26.5	24	18...28	19	3.9	□	1.2	2 050	-20...+70	80 000 / 40 000	135 000	②	
8414 NML	45	26.5	24	18...28	21	4.0	■	1.1	2 050	-20...+70	80 000 / 40 000	135 000	②	
8414 NGM	58	34.1	24	18...28	26	4.3	□	1.4	2 600	-20...+70	80 000 / 40 000	135 000	③	
8414 NM	58	34.1	24	18...28	27	4.4	■	1.4	2 600	-20...+70	80 000 / 40 000	135 000	③	
8414 NG	69	40.6	24	18...28	32	4.7	□	2.2	3 100	-20...+70	70 000 / 35 000	117 500	④	
8414 N	69	40.6	24	18...28	32	4.7	■	1.8	3 100	-20...+70	70 000 / 35 000	117 500	④	
8414 NH	79	46.5	24	18...26	37	5.0	■	2.4	3 600	-20...+70	70 000 / 35 000	117 500	⑤	
8414 NH-221	79	46.5	24	18...28	37	5.0	■	2.2	3 600	-20...+70	70 000 / 35 000	117 500	⑤	
8418 N	69	40.6	48	36...56	32	4.7	■	2.0	3 100	-20...+70	70 000 / 35 000	117 500	④	

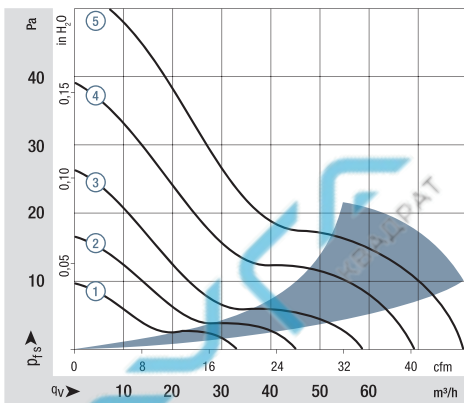

Air performance measured according to: ISO 5801.
Installation category A, without contact protection.
Noise: Total sound power level L_{WA} ISO 10302 measured on a hemisphere with a radius of 2 m.
Sound pressure level L_{pA} measured at 1 m distance from fan axis.
The values given are applicable only under the specified measuring conditions and may differ depending on the installation conditions.
In the event of deviation from the standard configuration, the parameters must be checked after installation!
For detailed information see <http://www.ebmpapst.com/general-conditions>

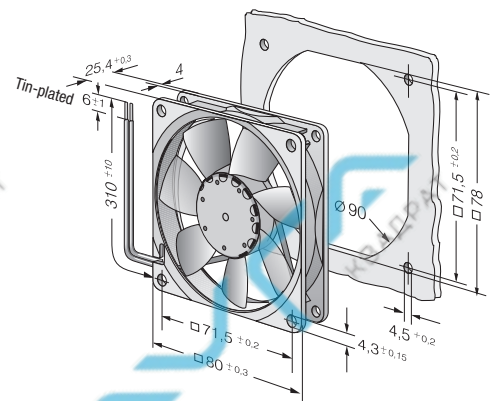

Max. 130 m³/h
S-Panther



DC axial fans

□ 80 x 32 mm

- **Material:** Housing: GRP¹⁾ (PBT)
Impeller: GRP¹⁾ (PA)
 - **Direction of air flow:** Exhaust over struts
 - **Direction of rotation:** Counterclockwise, looking towards rotor
 - **Connection:** Via single wires AWG 26, TR 64
 - **Weight:** 160 g
- **Possible special versions:** (See chapter DC fans - specials)
 - Speed signal
 - Go / NoGo alarm
 - Alarm with speed limit
 - External temperature sensor
 - Internal temperature sensor
 - PWM control input
 - Analog control input
 - Moisture protection
 - Salt spray protection
 - Degree of protection: IP 54 / IP 68

1) Fiberglass-reinforced plastic

Series 8300 N
WVC0080PUFBS

Nominal data

Type	Air flow		Nominal voltage		Voltage range		Sound pressure level	Sound power level	Sintec sleeve bearings	Ball bearings	Power consumption	Nominal speed	Temperature range	Service life L ₁₀ (40 °C) ebm-papst standard	Service life L ₁₀ (T _{max}) ebm-papst standard	Life expectancy L ₁₀ IPC (40 °C) see page 15	Curve
	m ³ /h	cfm	VDC	VDC	dB(A)	Bel(A)	□ / ■	Watts	rpm ⁻¹	°C	Hours	Hours	Hours				
8312 NL	32	19	12	6...15	24	4.0	■	1.0	2 300	-20...+75	105 000 / 42 500	180 000	①				
8312 NM	50	30	12	6...15	32	4.5	■	1.5	3 300	-20...+75	102 500 / 40 000	170 000	②				
8312 NN	56	33	12	6...15	33	4.7	■	1.8	3 700	-20...+75	97 500 / 37 500	162 500	③				
8314 NN	56	33	24	12...28	33	4.7	■	1.8	3 700	-20...+75	97 500 / 37 500	162 500	③				
8318 NN	56	33	48	36...60	33	4.7	■	1.5	3 700	-20...+75	97 500 / 37 500	162 500	③				

Subject to change

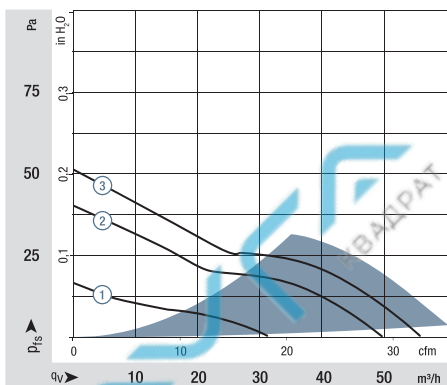

Air performance measured according to: ISO 5801.
Installation category A, without contact protection.
Noise: Total sound power level L_{WA} ISO 10302 measured on a hemisphere with a radius of 2 m.
Sound pressure level L_{pA} measured at 1 m distance from fan axis.

The values given are applicable only under the specified measuring conditions and may differ depending on the installation conditions.
In the event of deviation from the standard configuration, the parameters must be checked after installation!
For detailed information see <http://www.ebmpapst.com/general-conditions>

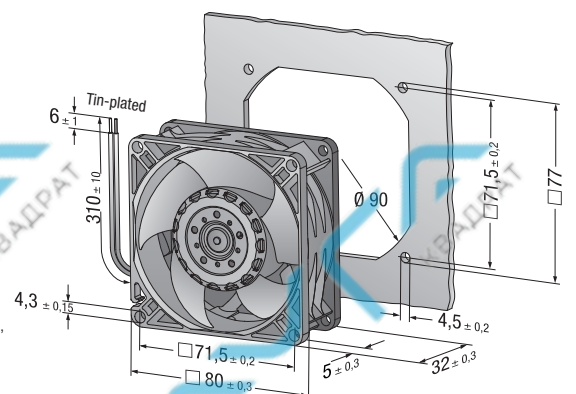

Max. 130 m³/h
S-Panther



DC axial fans

□ 80 x 32 mm

- **Material:** Housing: GRP¹⁾ (PBT)
Impeller: GRP¹⁾ (PA)
 - **Direction of air flow:** Exhaust over struts
 - **Direction of rotation:** Counterclockwise, looking towards rotor
 - **Connection:** Via single wires AWG 26, TR 64
 - **Weight:** 160 g
- **Possible special versions:** (See chapter DC fans - specials)
 - Speed signal
 - Go / NoGo alarm
 - Alarm with speed limit
 - External temperature sensor
 - Internal temperature sensor
 - PWM control input
 - Analog control input
 - Moisture protection
 - Salt spray protection
 - Degree of protection: IP 54 / IP 68

1) Fiberglass-reinforced plastic

Series 8300 N
WVC0080PUFBS

Nominal data

Type	Air flow		Nominal voltage		Sound pressure level		Sinter sleeve bearings Ball bearings	Power consumption	Nominal speed	Temperature range	Service life L ₁₀ (40 °C) ebm-papst standard	Service life L ₁₀ (T _{max}) ebm-papst standard	Life expectancy L ₁₀ IPC (40 °C) see page 15	Curve
	m ³ /h	cfm	VDC	VDC	dB(A)	Bel(A)								
8312 NHL	70	41	12	6...15	39	5.2	■	2.9	4 600	-20...+75	92 500 / 37 500	155 000	①	
8312 NH	80	47	12	6...15	42	5.5	■	4.0	5 300	-20...+75	82 500 / 32 500	140 000	②	
8312 NHH	95	56	12	6...15	48	6.0	■	5.4	6 300	-20...+75	72 500 / 27 500	120 000	③	
8312 NH3	115	68	12	6...13.2	53	6.6	■	9.4	7 600	-20...+75	57 500 / 25 000	100 000	④	
8312 NH4	130	77	12	6...12.8	56	6.9	■	12.6	8 500	-20...+60	52 500 / 32 500	87 500	⑤	
8314 NHL	70	41	24	12...28	39	5.2	■	2.6	4 600	-20...+75	92 500 / 37 500	155 000	①	
8314 NH	80	47	24	12...28	42	5.5	■	3.6	5 300	-20...+75	82 500 / 32 500	140 000	②	
8314 NHH	95	56	24	12...28	48	6.0	■	5.0	6 300	-20...+75	72 500 / 27 500	120 000	③	
8314 NH3	115	68	24	12...28	53	6.6	■	8.8	7 600	-20...+75	57 500 / 25 000	100 000	④	
8314 N/2H3P	115	68	24	18...28	53	6.6	■	8.0	7 600	-20...+75	75 000 / 30 000	127 500	④	
8318 NHL	70	41	48	36...60	39	5.2	■	2.3	4 600	-20...+75	92 500 / 37 500	155 000	①	
8318 NH	80	47	48	36...60	42	5.5	■	3.5	5 300	-20...+75	82 500 / 32 500	140 000	②	
8318 NHH	95	56	48	36...60	48	6.0	■	5.8	6 300	-20...+75	72 500 / 27 500	120 000	③	
8318 NH3	115	68	48	36...52.8	53	6.6	■	8.9	7 600	-20...+75	57 500 / 25 000	100 000	④	

Änderungen vorbehalten

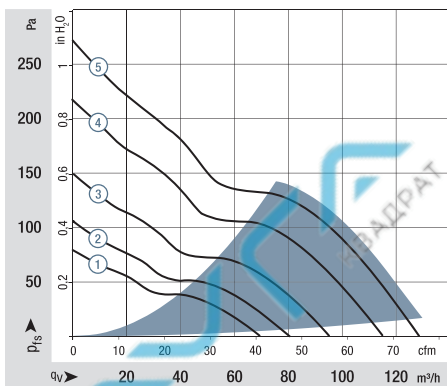

Air performance measured according to: ISO 5801.
Installation category A, without contact protection.
Noise: Total sound power level L_{WA} ISO 10302 measured on a hemisphere with a radius of 2 m.
Sound pressure level L_{pA} measured at 1 m distance from fan axis.
The values given are applicable only under the specified measuring conditions and may differ depending on the installation conditions.
In the event of deviation from the standard configuration, the parameters must be checked after installation!
For detailed information see <http://www.ebmpapst.com/general-conditions>

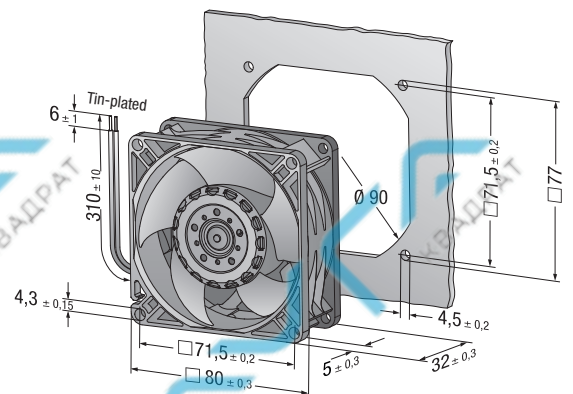

Max. 222 m³/h

DC axial fans

□ 80 x 38 mm



- **Material:** Housing: GRP¹⁾ (PBT)
Impeller: GRP¹⁾ (PA)
- **Direction of air flow:** Exhaust over struts
- **Direction of rotation:** Counterclockwise, looking towards rotor
- **Connection:** Via single wires AWG 24 (H3 and H4: AWG 22), TR 64
- **Weight:** 160 g (H3 and H4: 200 g)

- **Possible special versions:** (See chapter DC fans - specials)
 - Speed signal
 - Go / NoGo alarm
 - Alarm with speed limit
 - External temperature sensor
 - Internal temperature sensor
 - PWM control input
 - Analog control input
 - Moisture protection
 - Degree of protection: IP 54 / IP 68

1) Fiberglass-reinforced plastic

Series 8200 J
WVC0080JUFBS

Nominal data

Type	Air flow		Nominal voltage	Voltage range	Sound pressure level	Sound power level	Sinter sleeve bearings Ball bearings	Power consumption	Nominal speed	Temperature range	Service life L ₁₀ (40 °C) ebm-papst standard	Service life L ₁₀ (T _{max}) ebm-papst standard	Life expectancy L ₁₀ (IPC (40 °C) see page 15	Curve
	m ³ /h	cfm												
8212 JN	132	78	12	7...13.8	55	6.6	■	10	8 400	-20...+70	62 500 / 32 500	105 000	105 000	①
8212 JH3 <i>S-Force</i>	190	112	12	6...13.8	66	7.3	■	26*	12 000	-20...+70	55 000 / 27 500	92 500	92 500	②
8212 JH4 <i>S-Force</i>	222	131	12	6...13.8	71	7.8	■	39*	14 000	-20...+70	50 000 / 25 000	85 000	85 000	③
8214 JN	132	78	24	18...26.4	55	6.6	■	11	8 400	-20...+70	62 500 / 32 500	105 000	105 000	①
8214 JH3 <i>S-Force</i>	190	112	24	12...27.6	66	7.3	■	26*	12 000	-20...+70	55 000 / 27 500	92 500	92 500	②
8214 JH4 <i>S-Force</i>	222	131	24	12...27.6	71	7.8	■	38*	14 000	-20...+70	50 000 / 25 000	85 000	85 000	③
8218 JN	132	78	48	36...53	55	6.6	■	11	8 400	-20...+70	62 500 / 32 500	105 000	105 000	①
8218 JH3 <i>S-Force</i>	190	112	48	36...53	66	7.3	■	25*	12 000	-20...+70	55 000 / 27 500	92 500	92 500	②
8218 JH4 <i>S-Force</i>	222	131	48	20...58	71	7.8	■	36*	14 000	-20...+70	50 000 / 25 000	85 000	85 000	③

Subject to change

8200 JH3 and JH4 also available as standard with PWM control input and speed signal.
Speed control range from 2000 rpm⁻¹ up to maximum nominal speed. Standstill at 0% PWM, maximum speed if control cable is interrupted.
* Power consumption at free air flow. These values can be significantly higher in the operating point.

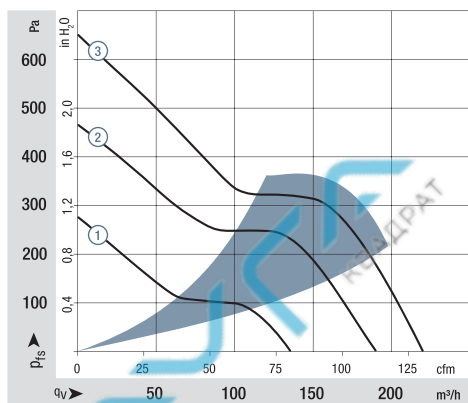

Air performance measured according to: ISO 5801.
Installation category A, without contact protection.
Noise: Total sound power level L_{WA} ISO 10302 measured on a hemisphere with a radius of 2 m.
Sound pressure level L_{pA} measured at 1 m distance from fan axis.
The values given are applicable only under the specified measuring conditions and may differ depending on the installation conditions.
In the event of deviation from the standard configuration, the parameters must be checked after installation!
For detailed information see <http://www.ebmpapst.com/general-conditions>

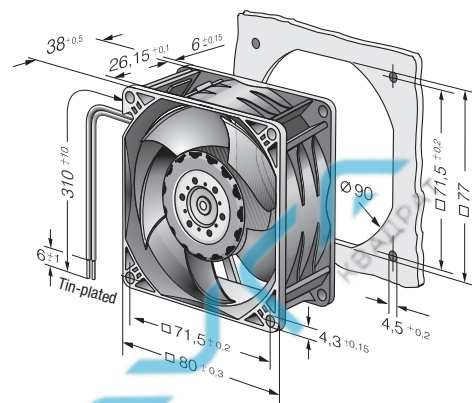

Max. 232 m³/h
S-Force

DC axial fan unit

□ 80 x 80 mm



- **Material:** Housing: GRP¹⁾ (PBT)
Impeller: GRP¹⁾ (PA)
 - **Direction of air flow:** Exhaust over struts
 - **Direction of rotation:** Counterclockwise, looking towards rotor
 - **Connection:** Via single wires AWG 22, TR 64
 - **Weight:** 430 g
- **Possible special versions:** (See chapter DC fans - specials)
 - Speed signal
 - Go / NoGo alarm
 - Alarm with speed limit
 - External temperature sensor
 - Internal temperature sensor
 - PWM control input
 - Analog control input
 - Moisture protection
 - Degree of protection: IP 54

1) Fiberglass-reinforced plastic

Series CoR 8200 J
VWK0075XUFBS
Co-Rotating with Honeycomb

Nominal data

Type	Air flow m ³ /h	Air flow cfm	Nominal voltage VDC	Voltage range VDC	Sound pressure level dB(A)	Sound power level Bel(A)	Sintec sleeve bearings Ball bearings	Power consumption Watts	Nominal speed rpm ⁻¹	Temperature range °C	Service life L ₁₀ (40 °C) ebm-papst standard Hours	Service life L ₁₀ (T _{max}) ebm-papst standard Hours	Life expectancy L ₁₀ IPC (40 °C) see page 15 Hours
CoR 8212 J/2H4P	232	136	12	6...13.8	90	8.7	■	70**	14 000	-20...+70	50 000 / 25 000	85 000	
CoR 8214 J*	232	136	24	12...27.6	90	8.7	■	67**	14 000	-20...+70	50 000 / 25 000	85 000	
CoR 8218 J*	232	136	48	20...58	90	8.7	■	65**	14 000	-20...+70	50 000 / 25 000	85 000	

Subject to change
* On request

** Power consumption at free air flow. These values can be significantly higher in the operating point.

	n rpm ⁻¹	P _{ed} W	L _{WA} dB(A)	L ₁₀ (40 °C)	L ₁₀ (T _{max})	L ₁₀ IPC (40 °C)		n rpm ⁻¹	P _{ed} W	L _{WA} dB(A)	L ₁₀ (40 °C)	L ₁₀ (T _{max})	L ₁₀ IPC (40 °C)		
100% PWM	① ①	14 000	65	90	50 000	25 000	85 000	50% PWM	③ ⑪	6 800	12	73	82 500	42 500	140 000
	① ②	14 000	75	89	50 000	25 000	85 000		③ ⑫	6 800	13	72	82 500	42 500	140 000
	① ③	14 000	84	88	55 000	27 500	92 500		③ ⑬	6 800	14	71	82 500	42 500	140 000
	① ④	14 000	86	87	55 000	27 500	92 500		③ ⑭	6 800	15	71	82 500	42 500	140 000
	① ⑤	14 000	87	87	57 500	27 500	97 500		③ ⑮	6 800	15	71	82 500	42 500	140 000
80% PWM	② ⑥	11 250	36	85	60 000	30 000	102 500								
	② ⑦	11 250	41	83	62 500	30 000	105 000								
	② ⑧	11 250	45	83	62 500	32 500	105 000								
	② ⑨	11 250	46	81	65 000	32 500	110 000								
	② ⑩	11 250	46	82	65 000	32 500	110 000								

Power consumption P_{ed} refer to CoR 8218 J.

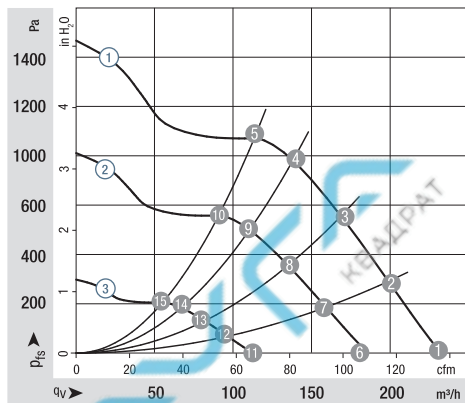

Air performance measured according to: ISO 5801.
Installation category A, without contact protection.
Noise: Total sound power level L_{WA} ISO 10302 measured on a hemisphere with a radius of 2 m.
Sound pressure level L_{pA} measured at 1 m distance from fan axis.
The values given are applicable only under the specified measuring conditions and may differ depending on the installation conditions.
In the event of deviation from the standard configuration, the parameters must be checked after installation!
For detailed information see <http://www.ebmpapst.com/general-conditions>

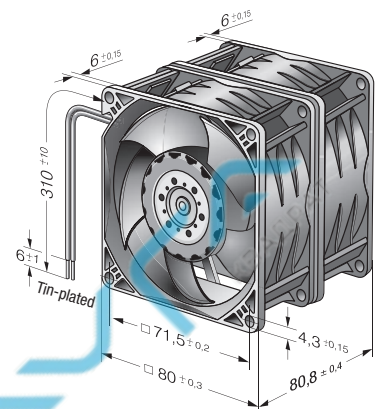

Max. 102 m³/h

DC axial fans

□ 92 x 25 mm



- **Material:** Housing: GRP¹⁾ (PBT)
Impeller: GRP¹⁾ (PA)
 - **Direction of air flow:** Exhaust over struts
 - **Direction of rotation:** Counterclockwise, looking towards rotor
 - **Connection:** Via single wires AWG 24, TR 64
 - **Weight:** 100 g
- **Possible special versions:** (See chapter DC fans - specials)
 - Speed signal
 - Go / NoGo alarm
 - Alarm with speed limit
 - External temperature sensor
 - Internal temperature sensor
 - PWM control input
 - Analog control input
 - Moisture protection
 - Degree of protection: IP 54 / IP 68

1) Fiberglass-reinforced plastic

Series 3400 N
WVC0092YUEBS

Nominal data

Type	Air flow		Nominal voltage	Voltage range	Sound pressure level	Sound power level	Sinter sleeve bearings Ball bearings	Power consumption	Nominal speed	Temperature range	Service life L ₁₀ (40 °C) ebm-papst standard	Service life L ₁₀ (T _{max}) ebm-papst standard	Life expectancy L ₁₀ (IPC (40 °C) see page 15	Curve
	m ³ /h	cfm												
3412 NGL	61	35.9	12	8...15	23	4.0	□	1.1	1 950	-20...+80	80 000 / 22 500	135 000	①	
3412 NLE	61	35.9	12	8...15	23	4.0	■	0.8	1 950	-20...+85	80 000 / 17 500	135 000	①	
3412 NGME	72	42.4	12	8...15	28	4.3	□	1.6	2 300	-20...+75	75 000 / 27 500	127 500	②	
3412 NME	72	42.4	12	8...15	28	4.3	■	1.1	2 300	-20...+75	75 000 / 27 500	127 500	②	
3412 NG	82	48.2	12	8...15	33	4.6	□	2.2	2 700	-20...+70	70 000 / 35 000	117 500	③	
3412 N	82	48.2	12	8...15	33	4.6	■	2.2	2 700	-20...+70	70 000 / 35 000	117 500	③	
3412 NGH	94	55.3	12	8...15	36	5.0	□	2.3	3 000	-20...+70	70 000 / 35 000	117 500	④	
3412 NH	94	55.3	12	8...15	36	5.0	■	2.1	3 000	-20...+70	70 000 / 35 000	117 500	④	
3412 NGH	102	60.0	12	8...13.2	39	5.1	□	3.2	3 250	-20...+60	70 000 / 45 000	117 500	⑤	
3412 NHH	102	60.0	12	8...13.2	39	5.1	■	2.9	3 250	-20...+60	70 000 / 45 000	117 500	⑤	
3412 NHH-379	102	60.0	12	8...15	39	5.1	■	2.7	3 250	-20...+70	70 000 / 35 000	117 500	⑤	
3414 NGL	61	35.9	24	18...28	23	4.0	□	1.4	1 950	-20...+70	80 000 / 40 000	135 000	①	
3414 NL	61	35.9	24	18...28	23	4.0	■	1.1	1 950	-20...+70	80 000 / 40 000	135 000	①	
3414 NGM	72	42.4	24	18...28	28	4.3	□	1.7	2 300	-20...+70	75 000 / 37 500	127 500	②	
3414 NM	72	42.4	24	18...28	28	4.3	■	1.4	2 300	-20...+70	75 000 / 37 500	127 500	②	
3414 NG	82	48.2	12	8...15	33	4.6	□	2.3	2 700	-20...+70	70 000 / 35 000	117 500	③	
3414 N	82	48.2	12	8...15	33	4.6	■	2.3	2 700	-20...+70	70 000 / 35 000	117 500	③	
3414 NGH	94	55.3	24	18...26	36	5.0	□	3.0	3 000	-20...+70	70 000 / 35 000	117 500	④	
3414 NH	94	55.3	24	18...26	36	5.0	■	2.3	3 000	-20...+70	70 000 / 35 000	117 500	④	
3414 NGH	102	60.0	24	18...26	39	5.1	□	3.2	3 250	-20...+70	70 000 / 35 000	117 500	⑤	
3414 NGH-389	102	60.0	24	18...28	39	5.1	□	3.2	3 250	-20...+70	70 000 / 35 000	117 500	⑤	
3414 NHH	102	60.0	24	18...26	39	5.1	■	3.1	3 250	-20...+70	70 000 / 35 000	117 500	⑤	
3414 NHH-386	102	60.0	24	18...28	39	5.1	■	3.2	3 250	-20...+70	70 000 / 35 000	117 500	⑤	
3418 N	82	48.2	12	8...15	33	4.6	■	2.4	2 700	-20...+70	70 000 / 35 000	117 500	③	

Other 48 VDC models on request.

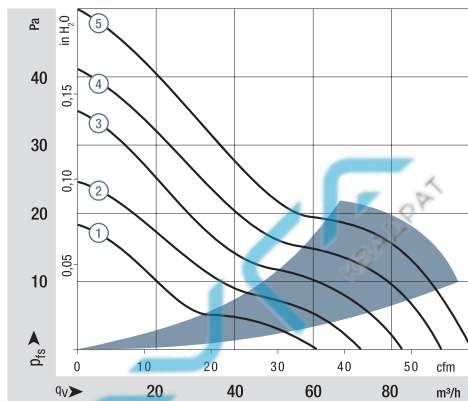

Air performance measured according to: ISO 5801.
Installation category A, without contact protection.
Noise: Total sound power level L_{WA} ISO 10302 measured on a hemisphere with a radius of 2 m.
Sound pressure level L_{pA} measured at 1 m distance from fan axis.
The values given are applicable only under the specified measuring conditions and may differ depending on the installation conditions.
In the event of deviation from the standard configuration, the parameters must be checked after installation!
For detailed information see <http://www.ebmpapst.com/general-conditions>

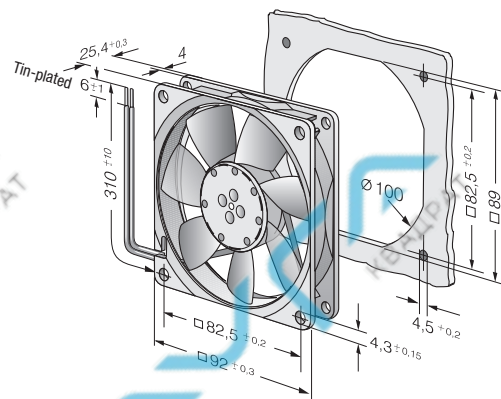

Max. 80 m³/h
S-Panther



DC axial fans

□ 92 x 32 mm

- **Material:** Housing: GRP¹⁾ (PBT)
Impeller: GRP¹⁾ (PA)
 - **Direction of air flow:** Exhaust over struts
 - **Direction of rotation:** Clockwise, looking towards rotor
 - **Connection:** Via single wires
AWG 24 UL 1061,
TR 64
 - **Weight:** 190 g
- **Possible special versions:**
(See chapter DC fans - specials)
 - Speed signal
 - Go / NoGo alarm
 - External temperature sensor
 - Internal temperature sensor
 - PWM control input
 - Analog control input
 - Moisture protection
 - Salt spray protection
 - Degree of protection: IP 54 / IP 68

1) Fiberglass-reinforced plastic

Series 3300 N
WVC0092PUGBS

Nominal data

Type	Air flow		Nominal voltage	Voltage range	Sound pressure level		Sintec sleeve bearings Ball bearings	Power consumption	Nominal speed	Temperature range	Service life L ₁₀ (40 °C) ebm-papst standard	Service life L ₁₀ (T _{max}) ebm-papst standard	Life expectancy L ₁₀ IPC (40 °C) see page 15	Curve
	m ³ /h	cfm			VDC	VDC								
3312 NL	56	33	12	6...15	24	4.0	■	0.8	1 850	-20...+75	87 500 / 35 000	147 500	①	
3312 NM	68	40	12	6...15	29	4.3	■	1.1	2 250	-20...+75	80 000 / 32 500	135 500	②	
3312 NN	80	47	12	6...15	35	4.7	■	1.8	2 650	-20...+75	77 500 / 30 000	130 000	③	
3314 NL	56	33	24	12...28	24	4.0	■	0.8	1 850	-20...+75	87 500 / 35 000	147 500	①	
3314 NM	68	40	24	12...28	29	4.3	■	1.2	2 250	-20...+75	80 000 / 32 500	135 500	②	
3314 NN	80	47	24	12...28	35	4.7	■	1.8	2 650	-20...+75	77 500 / 30 000	130 000	③	
3318 NN	80	47	48	36...60	35	4.7	■	1.8	2 650	-20...+75	77 500 / 30 000	130 000	③	

Subject to change

	n rpm ⁻¹	P _{ed} W	L _{WA} dB(A)	L ₁₀ (40 °C)	L ₁₀ (T _{max})	L ₁₀ IPC (40 °C)
① ①	1 870	0.9	39	82 500	47 500	140 000
① ②	1 860	0.9	39	80 000	45 000	135 000
① ③	1 860	0.9	39	80 000	45 000	135 000
① ④	1 870	0.9	39	77 500	42 500	130 000
② ①	2 220	1.2	42	77 500	42 500	130 000
② ②	2 220	1.3	42	75 000	42 500	127 500
② ③	2 210	1.3	42	72 500	40 000	122 500
② ④	2 220	1.3	44	72 500	40 000	122 500

	n rpm ⁻¹	P _{ed} W	L _{WA} dB(A)	L ₁₀ (40 °C)	L ₁₀ (T _{max})	L ₁₀ IPC (40 °C)
③ ①	2 650	1.9	46	75 000	42 500	127 500
③ ②	2 630	1.9	47	72 500	40 000	122 500
③ ③	2 630	1.9	47	70 000	40 000	117 500
③ ④	2 650	1.9	49	70 000	40 000	117 500

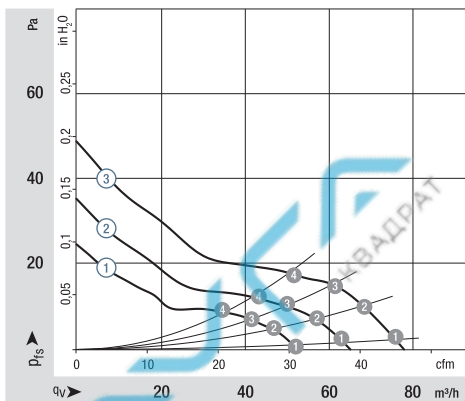

Air performance measured according to: ISO 5801.
Installation category A, without contact protection.
Noise: Total sound power level L_{WA} ISO 10302 measured on a hemisphere with a radius of 2 m.
Sound pressure level L_{pA} measured at 1 m distance from fan axis.
The values given are applicable only under the specified measuring conditions and may differ depending on the installation conditions.
In the event of deviation from the standard configuration, the parameters must be checked after installation!
For detailed information see <http://www.ebmpapst.com/general-conditions>

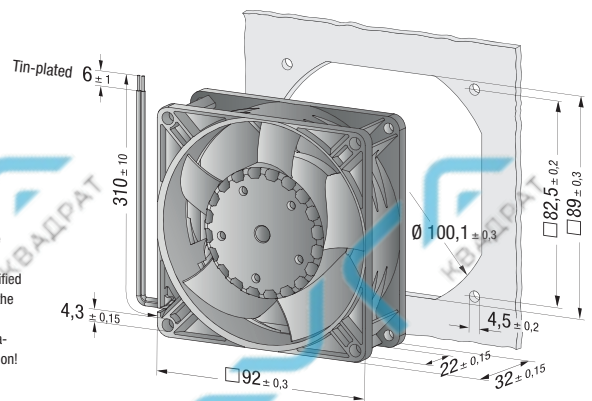

Max. 133 m³/h
S-Panther

DC axial fans

□ 92 x 32 mm



- **Material:** Housing: GRP¹⁾ (PBT)
Impeller: GRP¹⁾ (PA)
 - **Direction of air flow:** Exhaust over struts
 - **Direction of rotation:** Clockwise, looking towards rotor
 - **Connection:** Via single wires
AWG 24 UL 1061,
TR 64
 - **Weight:** 190 g
- **Possible special versions:**
(See chapter DC fans - specials)
 - Speed signal
 - Go / NoGo alarm
 - External temperature sensor
 - Internal temperature sensor
 - PWM control input
 - Analog control input
 - Moisture protection
 - Salt spray protection
 - Degree of protection: IP 54 / IP 68

1) Fiberglass-reinforced plastic

Series 3300 N
WVC0092PUGBS

Nominal data

Type	Air flow		Nominal voltage	Voltage range	Sound pressure level		Sinter sleeve bearings Ball bearings	Power consumption	Nominal speed	Temperature range	Service life L ₁₀ (40 °C) ebm-papst standard	Service life L ₁₀ (T _{max}) ebm-papst standard	Life expectancy L ₁₀ IPC (40 °C) see page 15	Curve
	m ³ /h	cfm			VDC	VDC								
3312 NH	93	55	12	6...15	38	5.1	■	2.8	3 050	-20...+75	72 500 / 30 000	122 500	④	
3312 NHH	107	63	12	6...15	42	5.4	■	3.4	3 450	-20...+75	67 500 / 27 500	115 000	⑤	
3312 NH3	133	78	12	6...14	50	6.0	■	6.9	4 350	-20...+70	60 000 / 30 000	102 500	⑥	
3312 N/2 H3P	133	78	12	7...13.2	50	6.0	■	5.5	4 350	-20...+80	60 000 / 20 000	102 500	⑥	
3314 NH	93	55	24	12...28	38	5.1	■	2.6	3 050	-20...+75	72 500 / 30 000	122 500	④	
3314 NHH	107	63	24	12...28	42	5.4	■	3.4	3 450	-20...+75	67 500 / 27 500	115 000	⑤	
3314 NH3	133	78	24	12...28	50	6.0	■	6.0	4 350	-20...+75	60 000 / 25 000	102 500	⑥	
3314 N/2 H3P	133	78	24	14...26.4	50	6.0	■	5.7	4 350	-20...+80	60 000 / 20 000	102 500	⑥	
3318 NH	93	55	48	36...60	38	5.1	■	2.6	3 050	-20...+75	72 500 / 30 000	122 500	④	
3318 NHH	107	63	48	36...60	42	5.4	■	3.4	3 450	-20...+75	67 500 / 27 500	115 000	⑤	
3318 NH3	133	78	48	36...58	50	6.0	■	6.5	4 350	-20...+75	60 000 / 25 000	102 500	⑥	
3318 N/2 H3P	133	78	48	36...56	50	6.0	■	6.1	4 350	-20...+80	60 000 / 20 000	102 500	⑥	

Subject to change

	n rpm ⁻¹	P _{ed} W	L _{WA} dB(A)	L ₁₀ (40 °C)	L ₁₀ (T _{max})	L ₁₀ IPC (40 °C)
④ ①	3 000	2.7	54	70 000	40 000	117 500
④ ②	3 000	2.7	50	67 500	37 500	115 000
④ ③	3 010	2.7	50	65 000	37 500	110 000
④ ④	3 040	2.6	52	65 000	37 500	110 000
⑤ ①	3 410	3.6	55	65 000	37 500	110 000
⑤ ②	3 400	3.7	54	62 500	35 000	105 000
⑤ ③	3 410	3.6	56	60 000	32 500	102 500
⑤ ④	3 440	3.5	58	60 000	32 500	102 500

	n rpm ⁻¹	P _{ed} W	L _{WA} dB(A)	L ₁₀ (40 °C)	L ₁₀ (T _{max})	L ₁₀ IPC (40 °C)
⑥ ①	4 300	6.6	61	57 500	32 500	97 500
⑥ ②	4 260	6.7	62	55 000	30 000	92 500
⑥ ③	4 280	6.7	63	55 000	30 000	92 500
⑥ ④	4 340	6.5	65	55 000	30 000	92 500

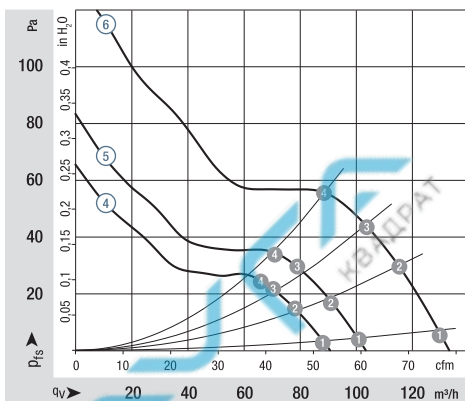

Air performance measured according to: ISO 5801.
Installation category A, without contact protection.
Noise: Total sound power level L_{WA} ISO 10302
measured on a hemisphere with a radius of 2 m.
Sound pressure level L_{pA} measured at 1 m distance
from fan axis.
The values given are applicable only under the specified
measuring conditions and may differ depending on the
installation conditions.
In the event of deviation from the standard configura-
tion, the parameters must be checked after installation!
For detailed information see
<http://www.ebmpapst.com/general-conditions>

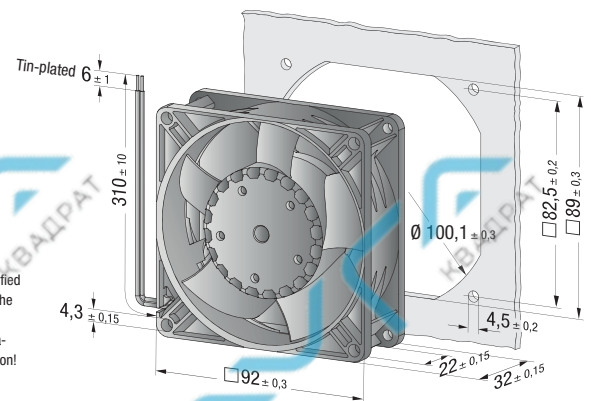

Max. 280 m³/h

DC axial fans

□ 92 x 38 mm



- **Material:** Housing: GRP¹⁾ (PBT)
Impeller: GRP¹⁾ (PA)
 - **Direction of air flow:** Exhaust over struts
 - **Direction of rotation:** Clockwise, looking towards rotor
 - **Connection:** Via single wires AWG 24 (H3 and H4: AWG 22), TR 64
 - **Weight:** 240 g (H3 and H4: 280 g)
- **Possible special versions:** (See chapter DC fans - specials)
 - Speed signal
 - Go / NoGo alarm
 - Alarm with speed limit
 - External temperature sensor
 - Internal temperature sensor
 - PWM control input
 - Analog control input
 - Moisture protection
 - Degree of protection: IP 54 / IP 68

1) Fiberglass-reinforced plastic

Series 3200 J
WVC0092JUGBS

Nominal data

Type	Air flow		Nominal voltage	Voltage range	Sound pressure level	Sound power level	Sinter sleeve bearings Ball bearings	Power consumption*	Nominal speed	Temperature range	Service life L ₁₀ (40 °C) ebm-papst standard	Service life L ₁₀ (T _{max}) ebm-papst standard	Life expectancy L ₁₀ (PC) (40 °C) see page 15	Curve
	m ³ /h	cfm												
3212 JN	130	77	12	7...13.8	51	6.1	■	7.5	6 000	-20 ...+70	70 000 / 35 000	117 500	①	
3212 JH	146	86	12	7...15	55	6.4	■	9.0	6 800	-20 ...+70	70 000 / 35 000	117 500	②	
3212 JH3 <i>S-Force</i>	237	139	12	6...13.8	69	7.8	■	31.0*	11 000	-20 ...+70	65 000 / 32 500	110 000	③	
3212 JH4 <i>S-Force</i>	280	165	12	6...13.8	73	8.2	■	50.0*	13 000	-20 ...+70	60 000 / 30 000	110 000	④	
3214 JN	130	77	24	11...28	51	6.1	■	6.5	6 000	-20 ...+70	70 000 / 35 000	117 500	①	
3214 JH	146	86	24	12...30	55	6.4	■	9.0	6 800	-20 ...+70	70 000 / 35 000	117 500	②	
3214 JH3 <i>S-Force</i>	237	139	24	12...27.6	69	7.8	■	30.0*	11 000	-20 ...+70	65 000 / 32 500	110 000	③	
3214 JH4 <i>S-Force</i>	280	165	24	12...27.6	73	8.2	■	50.0*	13 000	-20 ...+70	60 000 / 30 000	110 000	④	
3218 JN	130	77	48	36...56	51	6.1	■	7.0	6 000	-20 ...+70	70 000 / 35 000	117 500	①	
3218 JH	146	86	48	36...53	55	6.4	■	9.5	6 800	-20 ...+70	70 000 / 35 000	117 500	②	
3218 JH3 <i>S-Force</i>	237	139	48	20...58.0	69	7.8	■	29.0*	11 000	-20 ...+70	65 000 / 32 500	110 000	③	
3218 JH4 <i>S-Force</i>	280	165	48	20...58.0	73	8.2	■	50.0*	13 000	-20 ...+70	60 000 / 30 000	110 000	④	

Subject to change

3200 JH3 and JH4 also available as standard with PWM control input and speed signal.

Speed control range from 2000 rpm⁻¹ up to maximum nominal speed. Standstill at 0% PWM, maximum speed if control cable is interrupted.

* Power consumption at free air flow. These values can be significantly higher in the operating point.

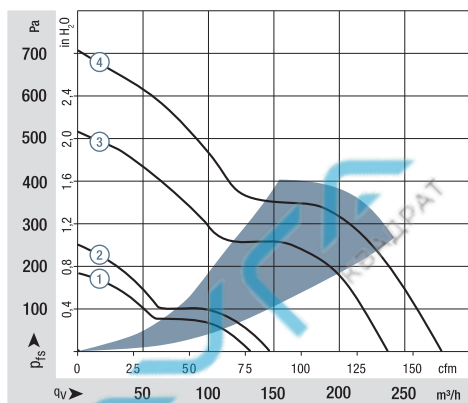

Air performance measured according to: ISO 5801.

Installation category A, without contact protection.

Noise: Total sound power level L_{WA} ISO 10302

measured on a hemisphere with a radius of 2 m.

Sound pressure level L_{pA} measured at 1 m distance from fan axis.

The values given are applicable only under the specified measuring conditions and may differ depending on the installation conditions.

In the event of deviation from the standard configuration, the parameters must be checked after installation!

For detailed information see

<http://www.ebmpapst.com/general-conditions>

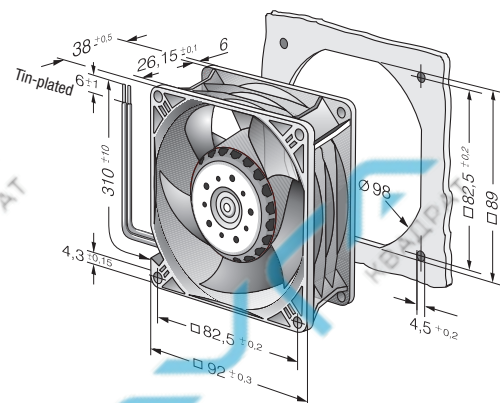

Max. 270 m³/h
S-Panther

DC axial fans

□ 92 x 38 mm



- **Material:** Housing: GRP¹⁾ (PBT)
Impeller: GRP¹⁾ (PA)
 - **Direction of air flow:** Exhaust over struts
 - **Direction of rotation:** Clockwise, looking towards rotor
 - **Connection:** Via single wires AWG 22, TR 64
 - **Weight:** 240 g
- **Possible special versions:** (See chapter DC fans - specials)
 - Speed signal
 - Go / NoGo alarm
 - External temperature sensor
 - Internal temperature sensor
 - PWM control input
 - Analog control input
 - Moisture protection
 - Salt spray protection
 - Degree of protection: IP 54 / IP 68

1) Fiberglass-reinforced plastic

Series 3250 J
WVC0092PUGCS

Nominal data

Type	Air flow		Nominal voltage	Voltage range	Sound pressure level		Sinter sleeve bearings Ball bearings	Power consumption*	Nominal speed	Temperature range	Service life L ₁₀ (40 °C) ebm-papst standard	Service life L ₁₀ (T _{max}) ebm-papst standard	Life expectancy L ₁₀ IPC (40 °C) see page 15	Curve
	m ³ /h	cfm			VDC	VDC								
3252 JH	140	82	12	7...13.2	46	5.8	■	7.0	4 100	-20...+70	100 000 / 50 000	170 000	170 000	①
3252 JH3	270	158	12	7...13.2	64	7.6	■	35.0	7 450	-20...+70	85 000 / 42 500	142 500	142 500	③
3254 JH	140	82	24	14...26.4	46	5.8	■	7.0	4 100	-20...+70	100 000 / 50 000	170 000	170 000	①
3254 J/2 H3P	270	158	24	14...26.4	64	7.6	■	35.0	7 450	-20...+70	85 000 / 42 500	142 500	142 500	③
3258 JH	140	82	48	36...56.0	46	5.8	■	7.0	4 100	-20...+70	100 000 / 50 000	170 000	170 000	①
3258 J/2 HHP	235	138	48	36...56.0	59	7.0	■	24.3	6 650	-20...+70	90 000 / 45 000	152 500	152 500	②
3258 J/2 H3P	270	158	48	36...56.0	64	7.6	■	34.0	7 450	-20...+70	85 000 / 42 500	142 500	142 500	③

Änderungen vorbehalten

* Power consumption at free air flow. These values can be significantly higher in the operating point.

	n rpm ⁻¹	P _{ed} W	L _{WA} dB(A)	L ₁₀ (40 °C)	L ₁₀ (T _{max})	L ₁₀ IPC (40 °C)		n rpm ⁻¹	P _{ed} W	L _{WA} dB(A)	L ₁₀ (40 °C)	L ₁₀ (T _{max})	L ₁₀ IPC (40 °C)
① ①	4096	7.5	46	92 500	47 500	155 000	③ ①	7562	37.5	64	82 500	40 000	140 000
① ②	4100	7.5	46	90 000	45 000	152 500	③ ②	7585	37.3	64	77 500	37 500	130 000
① ③	4120	7.3	46	90 000	45 000	152 500	③ ③	7649	36.9	64	72 500	37 500	122 500
② ①	6622	25.1	64	87 500	42 500	147 500							
② ②	6604	25.2	64	85 000	42 500	142 500							
② ③	6620	25.2	59	80 000	40 000	135 000							
② ④	6651	25	59	80 000	40 000	135 000							

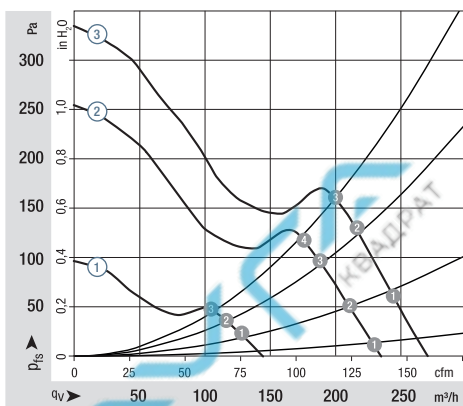

Air performance measured according to: ISO 5801.
Installation category A, without contact protection.
Noise: Total sound power level L_{WA} ISO 10302 measured on a hemisphere with a radius of 2 m.
Sound pressure level L_{pA} measured at 1 m distance from fan axis.
The values given are applicable only under the specified measuring conditions and may differ depending on the installation conditions.
In the event of deviation from the standard configuration, the parameters must be checked after installation!
For detailed information see <http://www.ebmpapst.com/general-conditions>

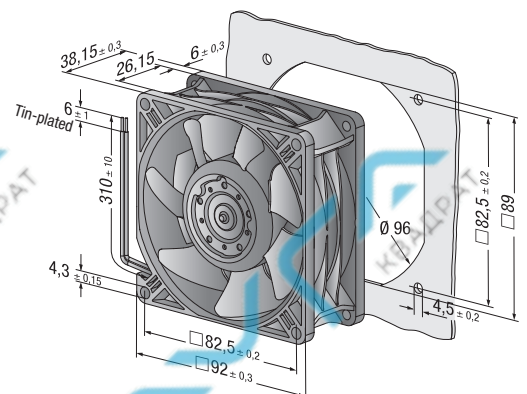

Max. 170 m³/h

DC axial fans

□ 119 x 25 mm



- **Material:** Housing: GRP¹⁾ (PBT)
Impeller: GRP¹⁾ (PA)
 - **Direction of air flow:** Exhaust over struts
 - **Direction of rotation:** Counterclockwise, looking towards rotor
 - **Connection:** Via single wires AWG 24, TR 64
 - **Highlights:** Ball bearings and sleeve bearings available
 - **Weight:** 175 g
- **Possible special versions:** (See chapter DC fans - specials)
 - Speed signal
 - Go / NoGo alarm
 - Alarm with speed limit
 - External temperature sensor
 - Internal temperature sensor
 - PWM control input
 - Analog control input
 - Moisture protection

1) Fiberglass-reinforced plastic

Series 4400 F
WVC0119FUGAS

Nominal data

Type	Air flow		Nominal voltage	Voltage range	Sound pressure level	Sound power level	Sinter sleeve bearings Ball bearings	Power consumption	Nominal speed	Temperature range	Service life L ₁₀ (40 °C) ebm-papst standard	Service life L ₁₀ (T _{max}) ebm-papst standard	Life expectancy L ₁₀ (PC) (40 °C) see page 15	Curve
	m ³ /h	cfm												
4412 FGL	94	55	12	7...14	26	3.9	□	1.2	1 600	-20...+75	80 000 / 32 500	135 000	①	
4412 FGML	114	67	12	7...12.6	32	4.3	□	2.0	1 950	-20...+75	75 000 / 30 000	127 500	②	
4412 FML	114	67	12	7...12.6	32	4.3	■	2.0	1 950	-20...+75	75 000 / 30 000	127 500	②	
4412 FGM	140	82	12	7...12.6	38	4.8	□	3.2	2 400	-20...+75	70 000 / 27 500	117 500	③	
4412 FM	140	82	12	7...12.6	38	4.8	■	3.2	2 400	-20...+75	70 000 / 27 500	117 500	③	
4412 FG	170	100	12	8...12.6	43	5.3	□	5.3	2 900	-20...+60	60 000 / 37 500	102 500	④	
4412 F	168	99	12	8...12.6	43	5.3	■	5.3	2 900	-20...+60	60 000 / 37 500	102 500	④	
4414 FL	94	55	24	18...28	26	3.9	■	1.2	1 600	-20...+75	80 000 / 32 500	135 000	①	
4414 FM	140	82	24	12...28	38	4.8	■	3.1	2 400	-20...+75	70 000 / 27 500	117 500	③	
4414 FG	170	100	24	12...28	43	5.3	□	5.0	2 900	-20...+60	60 000 / 37 500	102 500	④	
4414 F	168	99	24	12...28	43	5.3	■	5.0	2 900	-20...+60	60 000 / 37 500	102 500	④	
4418 FG	170	100	48	28...53	43	5.3	□	5.4	2 900	-20...+60	60 000 / 37 500	102 500	④	
4418 F	168	99	48	28...53	43	5.3	■	5.4	2 900	-20...+60	60 000 / 37 500	102 500	④	

Subject to change

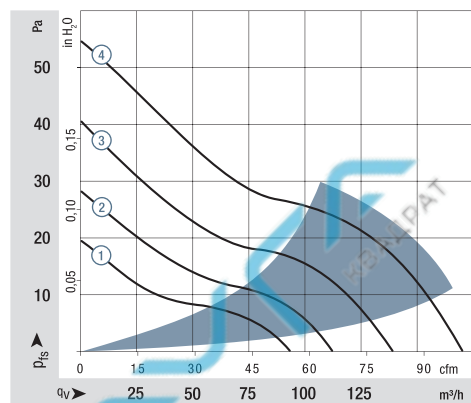

Air performance measured according to: ISO 5801.
Installation category A, without contact protection.
Noise: Total sound power level L_{WA} ISO 10302 measured on a hemisphere with a radius of 2 m.
Sound pressure level L_{pA} measured at 1 m distance from fan axis.
The values given are applicable only under the specified measuring conditions and may differ depending on the installation conditions.
In the event of deviation from the standard configuration, the parameters must be checked after installation!
For detailed information see <http://www.ebmpapst.com/general conditions>

Available as an option:
Fan housing with molded-in spacers

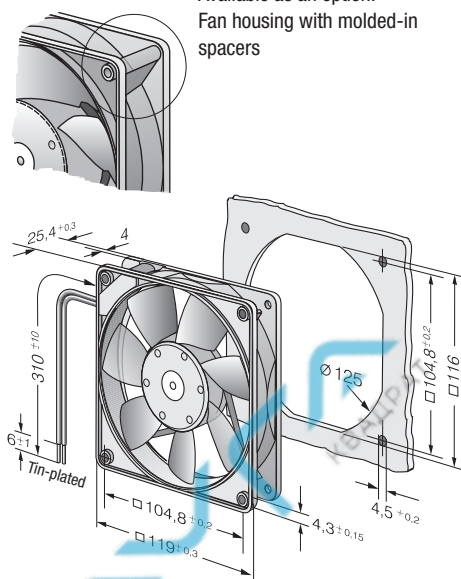

Max. 170 m³/h

DC axial fans

Ø 127 mm



- **Material:** Housing: GRP¹⁾ (PBT)
Impeller: GRP¹⁾ (PA)
- **Direction of air flow:** Exhaust over struts
- **Direction of rotation:** Counterclockwise, looking towards rotor
- **Connection:** Via single wires AWG 24, TR 64
- **Highlights:** Ball bearings and sleeve bearings available
Optional:
- Reversible direction of rotation
- Symmetrical impeller
- **Weight:** 170 g
- **Possible special versions:** (See chapter DC fans - specials)
 - Speed signal
 - Go / NoGo alarm
 - External temperature sensor
 - Internal temperature sensor
 - PWM control input
 - Analog control input
 - Moisture protection
 - Reversible direction of rotation
 - Symmetrical impeller

1) Fiberglass-reinforced plastic

Series 4400 F
round
VWS0113FUGAS

Nominal data

Type	Air flow		Nominal voltage		Sound pressure level		Sintec sleeve bearings Ball bearings	Power consumption	Nominal speed	Temperature range	Service life L ₁₀ (40 °C) ebm-papst standard	Service life L ₁₀ (T _{max}) ebm-papst standard	Life expectancy L ₁₀ IPC (40 °C) see page 15	Curve
	m ³ /h	cfm	VDC	VDC	dB(A)	Bel(A)								
4412 FGL-573	91	54	12	7...15	26	3.9	□	1.2	1 600	-20...+75	80 000 / 32 500	135 000	①	
4412 FGMPR-197	140	82	12	7...12.6	38	4.8	□	3.2	2 400	-20...+65	75 000 / 27 500	117 500	②	
4412 FGPR-194	170	100	12	8...12.6	43	5.3	□	5.3	2 900	-20...+50	60 000 / 37 500	102 500	③	

Subject to change

Other voltage versions (24 VDC, 48 VDC), speed variations and ball bearing designs are available as additional variants.

	n rpm ⁻¹	P _{ed} W	L _{WA} dB(A)		n rpm ⁻¹	P _{ed} W	L _{WA} dB(A)		n rpm ⁻¹	P _{ed} W	L _{WA} dB(A)
① ①	1515	1	44	② ①	2225	4	51	③ ①	2670	6	59
① ②	1516	1	38	② ②	2235	4	50	③ ②	2685	6	59
① ③	1547	1	40	② ③	2304	4	51	③ ③	2783	6	56
① ④	1567	1	39	② ④	2369	4	52	③ ④	2869	6	57

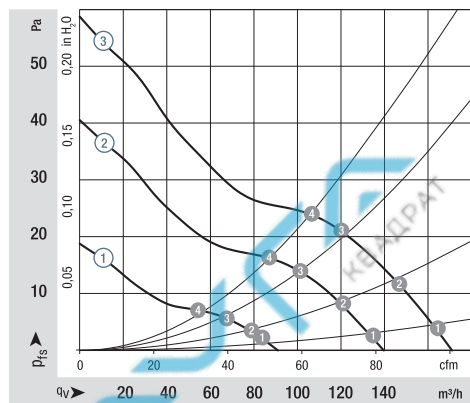

Air performance measured according to: ISO 5801.
Installation category A, without contact protection.
Noise: Total sound power level L_{WA} ISO 10302 measured on a hemisphere with a radius of 2 m.
Sound pressure level L_{pA} measured at 1 m distance from fan axis.
The values given are applicable only under the specified measuring conditions and may differ depending on the installation conditions.
In the event of deviation from the standard configuration, the parameters must be checked after installation!
For detailed information see <http://www.ebmpapst.com/general-conditions>

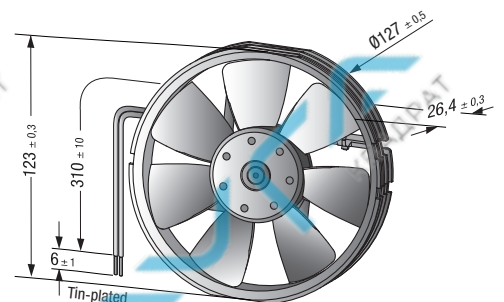

Max. 225 m³/h

DC axial fans

□ 119 x 25 mm



- **Material:** Housing: GRP¹⁾ (PBT)
Impeller: GRP¹⁾ (PA)
 - **Direction of air flow:** Exhaust over struts
 - **Direction of rotation:** Counterclockwise, looking towards rotor
 - **Connection:** Via single wires AWG 22, TR 64
 - **Weight:** 240 g
- **Possible special versions:** (See chapter DC fans - specials)
 - Speed signal
 - Go / NoGo alarm
 - Alarm with speed limit
 - External temperature sensor
 - Internal temperature sensor
 - PWM control input
 - Analog control input
 - Moisture protection

1) Fiberglass-reinforced plastic

Series 4400 FN
VWC119FUJBS

Nominal data

Type	Air flow		Nominal voltage	Voltage range	Sound pressure level	Sound power level	Sinter sleeve bearings Ball bearings	Power consumption	Nominal speed	Temperature range	Service life L ₁₀ (40 °C) ebm-papst standard	Service life L ₁₀ (T _{max}) ebm-papst standard	Life expectancy L ₁₀ (IPC (40 °C) see page 15	Curve
	m ³ /h	cfm												
4412 FNH	225	132	12	9...13.2	55	6.7	■	12	5 400	-20...+70	60 000 / 30 000	102 500	102 500	②
4414 FNN	200	118	24	14...28	52	6.5	■	8.3	4 850	-20...+70	60 000 / 30 000	102 500	102 500	①
4414 FNH	225	132	24	18...26.4	55	6.7	■	12	5 400	-20...+70	60 000 / 30 000	102 500	102 500	②
4418 FNH	225	132	48	36...53	55	6.7	■	12	5 400	-20...+70	60 000 / 30 000	102 500	102 500	②

Subject to change

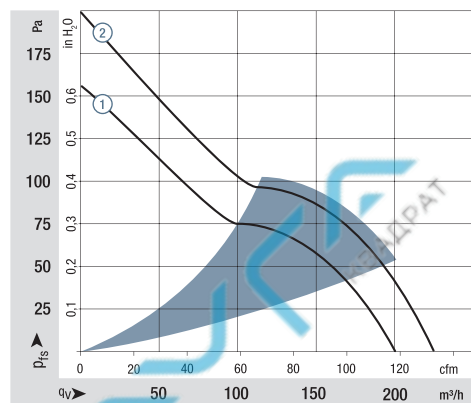

Air performance measured according to: ISO 5801.
Installation category A, without contact protection.
Noise: Total sound power level L_{WA} ISO 10302 measured on a hemisphere with a radius of 2 m.
Sound pressure level L_{pA} measured at 1 m distance from fan axis.
The values given are applicable only under the specified measuring conditions and may differ depending on the installation conditions.
In the event of deviation from the standard configuration, the parameters must be checked after installation!
For detailed information see <http://www.ebmpapst.com/general-conditions>

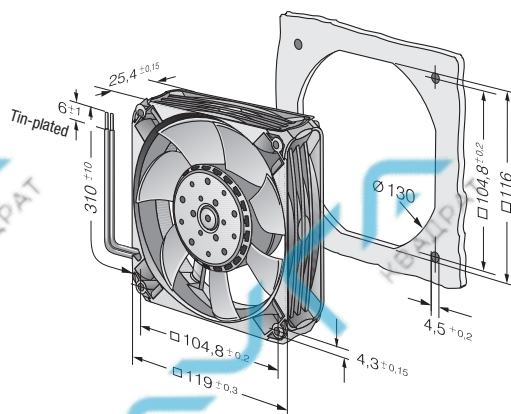

Max. 190 m³/h
S-Panther

DC axial fans

□ 119 x 32 mm



- **Material:** Housing: GRP¹⁾ (PBT)
Impeller: GRP¹⁾ (PA)
 - **Direction of air flow:** Exhaust over struts
 - **Direction of rotation:** Clockwise, looking towards rotor
 - **Connection:** Via single wires AWG 24, TR 64
 - **Highlights:** Ball bearings and sleeve bearings available
 - **Weight:** 250 g
- **Possible special versions:** (See chapter DC fans - specials)
 - Speed signal
 - Go / NoGo alarm
 - Alarm with speed limit
 - External temperature sensor
 - Internal temperature sensor
 - PWM control input
 - Analog control input
 - Moisture protection
 - Salt spray protection
 - Degree of protection: IP 54 / IP 68

1) Fiberglass-reinforced plastic

Series 4300 N
WVC0119PUGBS

Nominal data

Type	Air flow		Nominal voltage	Voltage range	Sound pressure level	Sound power level	Sintec sleeve bearings Ball bearings	Power consumption	Nominal speed	Temperature range	Service life L ₁₀ (40 °C) ebm-papst standard	Service life L ₁₀ (T _{max}) ebm-papst standard	Life expectancy L ₁₀ IPC (40 °C) see page 15	Curve
	m ³ /h	cfm												
4312 NL	100	59	12	6...15	25	3.9	■	0.9	1 450	-20...+75	95 000 / 37 500	160 000	①	
4312 NM	150	88	12	6...15	36	4.7	■	2.2	2 100	-20...+75	85 000 / 32 500	142 000	②	
4312 NN	190	112	12	6...15	43	5.4	■	4.3	2 700	-20...+75	72 500 / 30 000	122 000	③	
4314 NL	100	59	24	12...28	25	3.9	■	1.0	1 450	-20...+75	95 000 / 37 500	160 000	①	
4314 NM	150	88	24	12...28	36	4.7	■	2.4	2 100	-20...+75	85 000 / 32 500	142 000	②	
4314 NN	190	112	24	12...28	43	5.4	■	4.1	2 700	-20...+75	72 500 / 30 000	122 000	③	
4318 NN	190	112	48	36...60	43	5.4	■	4.3	2 700	-20...+75	72 500 / 30 000	122 000	③	

Subject to change

	n rpm ⁻¹	P _{ed} W	L _{WA} dB(A)	L ₁₀ (40 °C)	L ₁₀ (T _{max})	L ₁₀ IPC (40 °C)		n rpm ⁻¹	P _{ed} W	L _{WA} dB(A)	L ₁₀ (40 °C)	L ₁₀ (T _{max})	L ₁₀ IPC (40 °C)
① ①	1 410	0.9	41	95 000	37 500	160 000	③ ①	2 660	4.2	55	72 500	30 000	122 000
① ②	1 400	0.9	40	92 500	37 500	155 000	③ ②	2 660	4.3	55	70 000	27 500	117 500
① ③	1 430	0.9	39	92 500	37 500	155 000	③ ③	2 600	4.4	54	70 000	27 500	117 500
① ④	1 440	0.9	44	90 000	35 000	152 500	③ ④	2 620	4.4	54	65 000	25 000	110 000
② ①	2 150	2.2	49	85 000	32 500	142 000							
② ②	2 140	2.3	48	82 500	32 500	140 000							
② ③	2 110	2.3	47	82 500	32 500	140 000							
② ④	2 140	2.3	54	80 000	32 500	135 000							

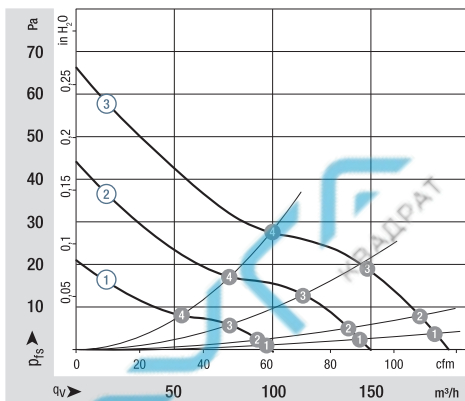

Air performance measured according to: ISO 5801.
Installation category A, without contact protection.
Noise: Total sound power level L_{WA} ISO 10302 measured on a hemisphere with a radius of 2 m.
Sound pressure level L_{pA} measured at 1 m distance from fan axis.
The values given are applicable only under the specified measuring conditions and may differ depending on the installation conditions.
In the event of deviation from the standard configuration, the parameters must be checked after installation!
For detailed information see <http://www.ebmpapst.com/general-conditions>

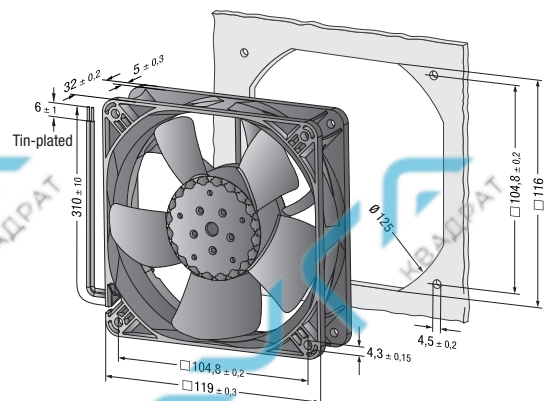

Max. 285 m³/h
S-Panther



DC axial fans

□ 119 x 32 mm

- **Material:** Housing: GRP¹⁾ (PBT)
Impeller: GRP¹⁾ (PA)
 - **Direction of air flow:** Exhaust over struts
 - **Direction of rotation:** Clockwise, looking towards rotor
 - **Connection:** Via single wires AWG 24, TR 64
 - **Highlights:** Ball bearings and sleeve bearings available
 - **Weight:** 250 g
- **Possible special versions:** (See chapter DC fans - specials)
 - Speed signal
 - Go / NoGo alarm
 - Alarm with speed limit
 - External temperature sensor
 - Internal temperature sensor
 - PWM control input
 - Analog control input
 - Moisture protection
 - Salt spray protection
 - Degree of protection: IP 54 / IP 68

1) Fiberglass-reinforced plastic

Series 4300 N
WVC0119PUGBS

Nominal data	Air flow		Nominal voltage	Voltage range	Sound pressure level		Sintec sleeve bearings Ball bearings	Power consumption	Nominal speed	Temperature range	Service life L ₁₀ (40 °C) ebm-papst standard	Service life L ₁₀ (T _{max}) ebm-papst standard	Life expectancy L ₁₀ IPC (40 °C) see page 15	Curve
	m ³ /h	cfm			VDC	VDC								
4312 NH	220	129	12	6...15	47	5.8	■	7.6	3 150	-20...+75	62 500 / 25 000	105 000	①	
4312 NHH	250	147	12	6...14.4	51	6.2	■	10.7	3 600	-20...+65	52 500 / 30 000	87 500	②	
4312 NH3	285	168	12	7...13.2	55	6.6	■	12.0	4 050	-20...+70	45 000 / 17 500	75 000	③	
4314 NH	220	129	24	12...28	47	5.8	■	6.7	3 150	-20...+75	62 500 / 25 000	105 000	①	
4314 NHH	250	147	24	12...27	51	6.2	■	9.8	3 600	-20...+70	52 500 / 27 500	87 500	②	
4314 NH3	285	168	24	14...26.4	55	6.6	■	11.0	4 050	-20...+70	45 000 / 17 500	75 000	③	
4318 NH	220	129	48	36...60	47	5.8	■	6.7	3 150	-20...+75	62 500 / 25 000	105 000	①	
4318 NH3	285	168	48	36...52.8	55	6.6	■	11.5	4 050	-20...+65	45 000 / 17 500	75 000	③	

Subject to change

	n rpm ⁻¹	P _{ed} W	L _{WA} dB(A)	L ₁₀ (40 °C)	L ₁₀ (T _{max})	L ₁₀ IPC (40 °C)		n rpm ⁻¹	P _{ed} W	L _{WA} dB(A)	L ₁₀ (40 °C)	L ₁₀ (T _{max})	L ₁₀ IPC (40 °C)
① ①	3 180	6.8	60	60 000	25 000	102 500	③ ①	4 070	12	67	42 500	17 500	72 500
① ②	3 150	6.9	60	57 500	22 500	97 500	③ ②	4 030	12	66	37 500	15 000	62 500
① ③	3 100	7.0	58	57 500	22 500	97 500	③ ③	3 960	12	66	37 500	15 000	62 500
① ④	3 140	6.9	64	57 500	22 500	97 500	③ ④	4 020	12	70	45 000	17 500	75 000
② ①	3 600	10	65	50 000	25 000	85 000							
② ②	3 540	10	63	47 500	25 000	80 000							
② ③	3 480	10	62	45 000	22 500	75 000							
② ④	3 500	10	63	50 000	25 000	85 000							

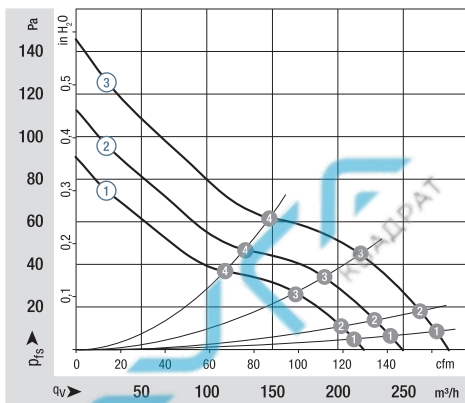

Air performance measured according to: ISO 5801.
Installation category A, without contact protection.
Noise: Total sound power level L_{WA} ISO 10302 measured on a hemisphere with a radius of 2 m.
Sound pressure level L_{pA} measured at 1 m distance from fan axis.
The values given are applicable only under the specified measuring conditions and may differ depending on the installation conditions.
In the event of deviation from the standard configuration, the parameters must be checked after installation!
For detailed information see <http://www.ebmpapst.com/general-conditions>

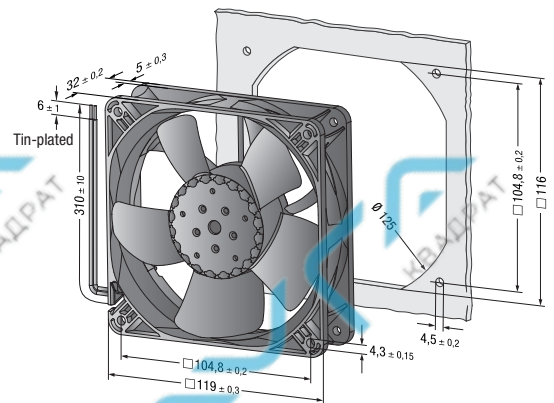

Max. 205 m³/h

DC axial fans

□ 119 x 38 mm



- **Material:** Housing: GRP¹⁾ (PBT)
Impeller: GRP¹⁾ (PA)
 - **Direction of air flow:** Exhaust over struts
 - **Direction of rotation:** Clockwise, looking towards rotor
 - **Connection:** Via single wires AWG 24, TR 64
 - **Weight:** 270 g
- **Possible special versions:** (See chapter DC fans - specials)
 - Speed signal
 - Go / NoGo alarm
 - Alarm with speed limit
 - External temperature sensor
 - Internal temperature sensor
 - PWM control input
 - Analog control input
 - Moisture protection
 - Degree of protection: IP 54

1) Fiberglass-reinforced plastic

Series 4400
WVC0119AUGBS

Nominal data

Type	Air flow		Nominal voltage		Sound pressure level		Sinter sleeve bearings Ball bearings	Power consumption	Nominal speed	Temperature range	Service life L ₁₀ (40 °C) ebm-papst standard	Service life L ₁₀ (T _{max}) ebm-papst standard	Life expectancy L ₁₀ (40 °C) see page 15	Curve
	m ³ /h	cfm	VDC	VDC	dB(A)	Bel(A)								
4412 L	150	88	12	7...14	37	5.0	■	2.2	2 700	-20...+80	67 500 / 22 500	115 000	③	
4412 ML	168	99	12	7...15	40	5.1	■	3.0	3 000	-20...+80	67 500 / 22 500	115 000	④	
4412 M	184	108	12	7...14	42	5.3	■	3.8	3 300	-20...+75	65 000 / 25 000	110 000	⑤	
4412 N	205	121	12	7...14	46	5.6	■	5.3	3 650	-20...+70	62 500 / 30 000	105 000	⑥	
4414 L3	100	59	24	12...28	26	4.0	■	1.0	1 800	-20...+80	75 500 / 22 500	127 500	①	
4414 LL	124	73	24	12...28	33	4.5	■	1.6	2 250	-20...+80	70 000 / 22 500	117 500	②	
4414 L	150	88	24	18...28	37	5.0	■	2.4	2 700	-20...+80	67 500 / 22 500	115 000	③	
4414 ML	168	99	24	12...28	40	5.1	■	3.2	3 000	-20...+80	67 500 / 22 500	115 000	④	
4414 M	184	108	24	18...28	42	5.3	■	4.1	3 300	-20...+75	65 000 / 25 000	110 000	⑤	
4414 N	205	121	24	18...28	46	5.6	■	5.4	3 650	-20...+70	62 500 / 30 000	105 000	⑥	
4418 L	150	88	48	36...60	37	5.0	■	2.5	2 700	-20...+75	67 500 / 27 500	115 000	③	
4418 ML	168	99	48	36...60	40	5.1	■	3.2	3 000	-20...+75	67 500 / 27 500	115 000	④	
4418 M	184	108	48	36...60	42	5.3	■	4.2	3 300	-20...+70	65 000 / 32 500	110 000	⑤	
4418 N	205	121	48	36...60	46	5.6	■	5.4	3 650	-20...+70	62 500 / 30 000	105 000	⑥	

Subject to change

Further variants can be found on page 57.

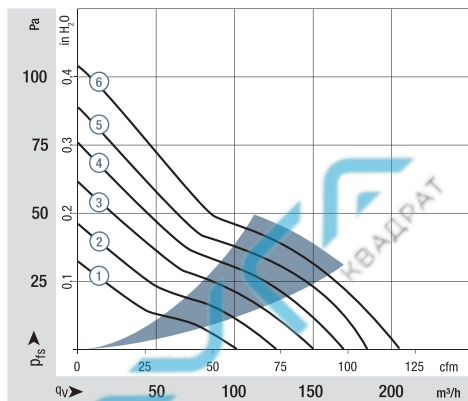

Air performance measured according to: ISO 5801.
Installation category A, without contact protection.
Noise: Total sound power level L_{WA} ISO 10302 measured on a hemisphere with a radius of 2 m.
Sound pressure level L_{pA} measured at 1 m distance from fan axis.
The values given are applicable only under the specified measuring conditions and may differ depending on the installation conditions.
In the event of deviation from the standard configuration, the parameters must be checked after installation!
For detailed information see <http://www.ebmpapst.com/general conditions>

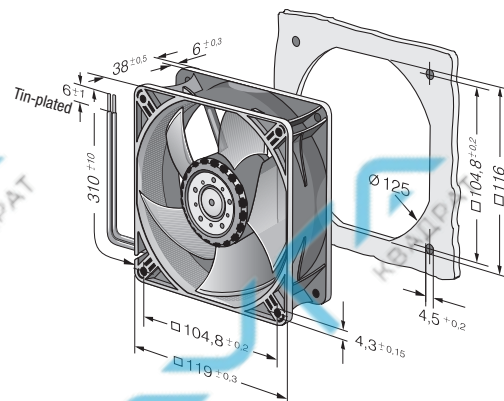

Max. 285 m³/h

DC axial fans

□ 119 x 38 mm



- **Material:** Housing: GRP¹⁾ (PBT)
Impeller: GRP¹⁾ (PA)
 - **Direction of air flow:** Exhaust over struts
 - **Direction of rotation:** Clockwise, looking towards rotor
 - **Connection:** Via single wires AWG 24, TR 64
 - **Weight:** 270 g
- **Possible special versions:** (See chapter DC fans - specials)
 - Speed signal
 - Go / NoGo alarm
 - Alarm with speed limit
 - External temperature sensor
 - Internal temperature sensor
 - PWM control input
 - Analog control input
 - Moisture protection
 - Degree of protection: IP 54

1) Fiberglass-reinforced plastic

Series 4400
WVC0119AUGBS

Nominal data

Type	Air flow		Nominal voltage	Voltage range	Sound pressure level	Sound power level	Sinter sleeve bearings Ball bearings	Power consumption	Nominal speed	Temperature range	Service life L ₁₀ (40 °C) ebm-papst standard	Service life L ₁₀ (T _{max}) ebm-papst standard	Life expectancy L ₁₀ (IPC (40 °C) see page 15	Curve
	m ³ /h	cfm												
4412 H	240	141	12	7...14	50	6.0	■	8.6	4 300	-20...+70	57 500 / 27 500	97 500	97 500	①
4412/2 HHP	285	168	12	7...14.5	55	6.4	■	13.0	5 000	-20...+70	50 000 / 25 000	85 000	85 000	②
4414 H	240	141	24	18...28	50	6.0	■	8.6	4 300	-20...+70	57 500 / 27 500	97 500	97 500	①
4414 HH	285	165	24	16...28	55	6.4	■	14.0	5 000	-20...+70	50 000 / 25 000	85 000	85 000	②
4414/2 HHP	285	168	24	18...28	55	6.4	■	12.0	5 000	-20...+70	50 000 / 25 000	85 000	85 000	②
4418 H	240	141	48	36...60	50	6.0	■	8.6	4 300	-20...+70	57 500 / 27 500	97 500	97 500	①
4418/2 HHP	285	168	48	36...60	55	6.4	■	13.0	5 000	-20...+70	50 000 / 25 000	85 000	85 000	②

Subject to change

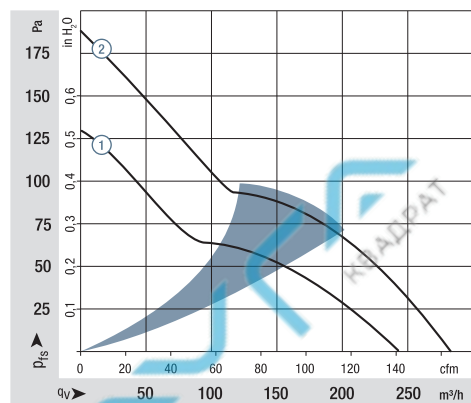

Air performance measured according to: ISO 5801.
Installation category A, without contact protection.
Noise: Total sound power level L_{WA} ISO 10302 measured on a hemisphere with a radius of 2 m.
Sound pressure level L_{pA} measured at 1 m distance from fan axis.
The values given are applicable only under the specified measuring conditions and may differ depending on the installation conditions.
In the event of deviation from the standard configuration, the parameters must be checked after installation!
For detailed information see <http://www.ebmpapst.com/general conditions>

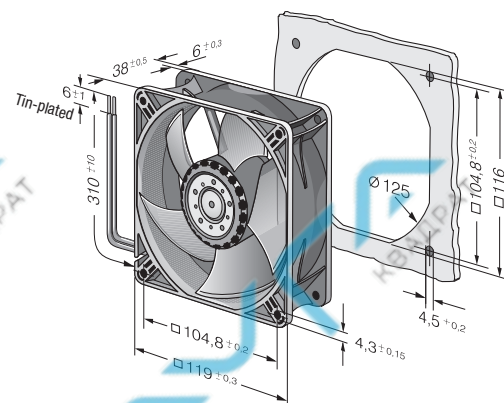

Max. 237 m³/h

DC axial fans

□ 119 x 38 mm

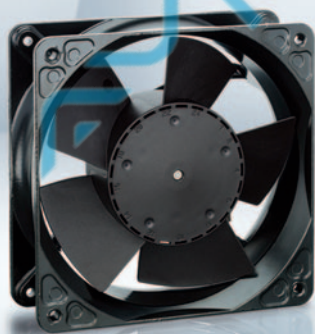

- **Material:** Housing: Die-cast aluminum
Impeller: GRP¹⁾ (PA)
 - **Direction of air flow:** Intake over struts
 - **Direction of rotation:** Clockwise, looking towards rotor
 - **Connection:** On flat connectors, 2.8 x 0.5 mm
Also available with wires as an option
 - **Highlights:** Housing with grounding lug for screw M4 x 8 (Torx)
 - **Weight:** 390 g
- **Possible special versions:** (See chapter DC fans - specials)
 - Speed signal
 - Go / NoGo alarm
 - Alarm with speed limit
 - External temperature sensor
 - Internal temperature sensor
 - PWM control input
 - Analog control input
 - Moisture protection
 - Salt spray protection
 - Degree of protection: IP 54 / IP 68

1) Fiberglass-reinforced plastic

Series 4100 N
VUC0119YUJBS

Nominal data

Type	Air flow		Nominal voltage	Voltage range	Sound pressure level	Sound power level	Sintec sleeve bearings Ball bearings	Power consumption	Nominal speed	Temperature range	Service life L ₁₀ (40 °C) ebm-papst standard	Service life L ₁₀ (T _{max}) ebm-papst standard	Life expectancy L ₁₀ IPC (40 °C) see page 15	Curve
	m ³ /h	cfm												
4182 NGX	160	94	12	6...15	44	5.3	□	3.7	2 800	-20...+75	85 000 / 37 500	142 500	142 500	①
4182 NX	180	106	12	6...15	49	5.7	■	4.9	3 200	-30...+75	85 000 / 37 500	142 500	142 500	②
4182 NXH	237	140	12	7...14	57	6.5	■	11.0	4 400	-30...+55	70 000 / 50 000	117 500	117 500	③
4184 NGX	160	94	24	12...31.5	44	5.3	□	3.3	2 800	-20...+75	85 000 / 37 500	142 500	142 500	①
4184 NXM	160	94	24	12...31.5	44	5.3	■	3.2	2 800	-30...+75	85 000 / 37 500	142 500	142 500	①
4184 NX	180	106	24	12...31.5	49	5.7	■	4.9	3 200	-30...+70	85 000 / 42 500	142 500	142 500	②
4184 NXH	237	140	24	12...28	57	6.5	■	11.0	4 400	-30...+70	70 000 / 35 000	117 500	117 500	③
4188 NGX	160	94	48	36...60	44	5.3	□	3.6	2 800	-20...+75	85 000 / 37 500	142 500	142 500	①
4188 NXM	160	94	48	36...60	44	5.3	■	3.5	2 800	-30...+75	85 000 / 37 500	142 500	142 500	①

Subject to change

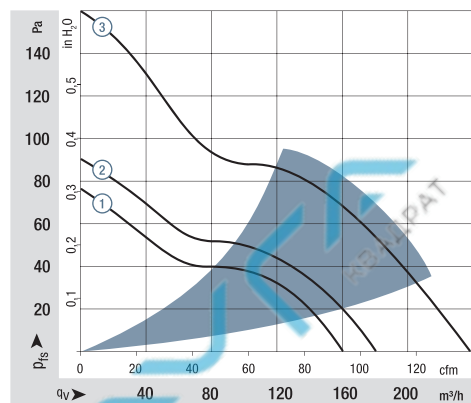

Air performance measured according to: ISO 5801.
Installation category A, without contact protection.
Noise: Total sound power level L_{WA} ISO 10302 measured on a hemisphere with a radius of 2 m.
Sound pressure level L_{pA} measured at 1 m distance from fan axis.
The values given are applicable only under the specified measuring conditions and may differ depending on the installation conditions.
In the event of deviation from the standard configuration, the parameters must be checked after installation!
For detailed information see <http://www.ebmpapst.com/general-conditions>

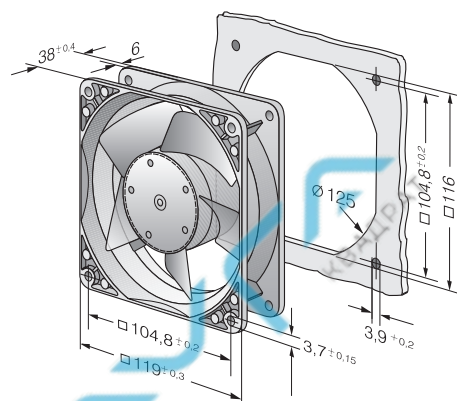

Max. 440 m³/h

DC axial fans

□ 119 x 38 mm



- **Material:** Housing: Die-cast aluminum
Impeller: GRP¹⁾ (PA)
 - **Direction of air flow:** Intake over struts
 - **Direction of rotation:** Clockwise, looking towards rotor
 - **Connection:** Via single wires
AWG 22 UL 1007, TR 64
 - **Highlights:** Housing with grounding lug for screw M4 x 8 (Torx)
 - **Weight:** 390 g
- **Possible special versions:** (See chapter DC fans - specials)
 - Speed signal
 - Go / NoGo alarm
 - Alarm with speed limit
 - External temperature sensor
 - Internal temperature sensor
 - PWM control input
 - Analog control input
 - Moisture protection
 - Salt spray protection
 - Degree of protection: IP 54 / IP 68

1) Fiberglass-reinforced plastic

Series 4100 N
High Performance
VUC0119YUJBS

Nominal data

Type	Air flow		Nominal voltage	Voltage range	Sound pressure level		Sinter sleeve bearings Ball bearings	Power consumption*	Nominal speed	Temperature range	Service life L ₁₀ (40 °C) ebm-papst standard	Service life L ₁₀ (T _{max}) ebm-papst standard	Life expectancy L ₁₀ (IPC (40 °C) see page 15	Curve
	m ³ /h	cfm			VDC	VDC								
4112 NHH	260	153	12	9...15	60	6.8	■	13.3	5 000	-20...+65	70 000 / 40 000	117 500	117 500	①
4112 NH3	310	182	12	9...15	65	7.2	■	21.6	6 000	-20...+65	65 000 / 37 500	110 000	110 000	②
4112 NH4	355	209	12	9...14	67	7.4	■	32.0	6 800	-20...+65	62 500 / 35 000	105 000	105 000	③
4114 NHH	260	153	24	16...30	60	6.8	■	12.4	5 000	-20...+65	70 000 / 40 000	117 500	117 500	①
4114 NH3	310	182	24	16...30	65	7.2	■	19.5	6 000	-20...+65	65 000 / 37 500	110 000	110 000	②
4114 NH4	355	209	24	16...30	67	7.4	■	30.0	6 800	-20...+65	62 500 / 35 000	105 000	105 000	③
4114 NH5 <i>S-Force</i>	390	230	24	16...30	70	7.6	■	45.0*	7 500	-20...+65	62 500 / 35 000	105 000	105 000	④
4114 NH6 <i>S-Force</i>	440	259	24	16...30	73	8.1	■	65.0*	8 400	-20...+65	60 000 / 32 500	102 500	102 500	⑤
4118 NHH	260	153	48	36...60	60	6.8	■	12.0	5 000	-20...+65	70 000 / 40 000	117 500	117 500	①
4118 NH3	310	182	48	36...60	65	7.2	■	20.0	6 000	-20...+65	65 000 / 37 500	110 000	110 000	②
4118 NH4	355	209	48	36...60	67	7.4	■	28.0	6 800	-20...+65	62 500 / 35 000	105 000	105 000	③
4118 NH5 <i>S-Force</i>	390	230	48	36...60	70	7.6	■	45.0*	7 500	-20...+65	62 500 / 35 000	105 000	105 000	④
4118 NH6 <i>S-Force</i>	440	259	48	36...60	73	8.1	■	62.0*	8 400	-20...+65	60 000 / 32 500	102 500	102 500	⑤

Subject to change

* Power consumption at free air flow. These values can be significantly higher in the operating point.

* Power consumption – in operation

Fan type	optimum operating range (W)
4114 NH5	55
4114 NH6	95
4118 NH5	55
4118 NH6	95

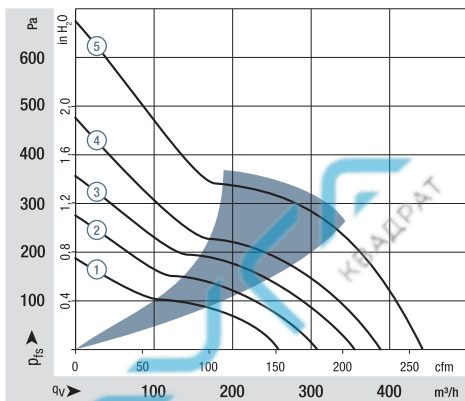

Air performance measured according to: ISO 5801.
Installation category A, without contact protection.
Noise: Total sound power level L_{WA} ISO 10302 measured on a hemisphere with a radius of 2 m.
Sound pressure level L_{pA} measured at 1 m distance from fan axis.
The values given are applicable only under the specified measuring conditions and may differ depending on the installation conditions.
In the event of deviation from the standard configuration, the parameters must be checked after installation!
For detailed information see <http://www.ebmpapst.com/general-conditions>

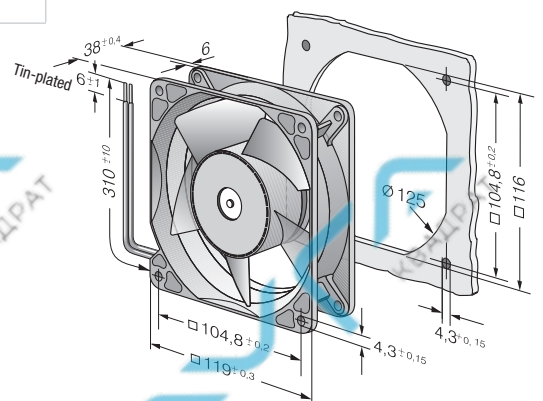

Max. 540 m³/h
S-Force

DC axial fans

□ 119 x 38 mm



- **Material:** Housing: Die-cast aluminum
Impeller: GRP¹⁾ (PA)
- **Direction of air flow:** Intake over struts
- **Direction of rotation:** Clockwise, looking towards rotor
- **Connection:** Via single wires AWG 18, 20 or AWG 22, TR 64, speed signal and control input AWG 22
- **Highlights:** Highly efficient and smoothly operating 3-phase fan drive
Housing with grounding lug for screw M4 x 8 (Torx)
- **Weight:** 425 g

- **Possible special versions:** (See chapter DC fans - specials)
 - Speed signal
 - Go / NoGo alarm
 - Alarm with speed limit
 - External temperature sensor
 - Internal temperature sensor
 - PWM control input (standard)
 - Analog control input
 - Moisture protection

1) Fiberglass-reinforced plastic

Series 4100 N
High Performance
VUC0119YUJCS

Nominal data

Type	Air flow		Nominal voltage		Voltage range		Sound pressure level	Sound power level	Sintec sleeve bearings	Ball bearings	Power consumption*	Nominal speed	Temperature range	Service life L ₁₀ (40 °C) ebm-papst standard	Service life L ₁₀ (T _{max}) ebm-papst standard	Life expectancy L ₁₀ IPC (40 °C) see page 15	Curve
	m ³ /h	cfm	VDC	VDC	dB(A)	Bel(A)	□ / ■	Watts	rpm ⁻¹	°C	Hours	Hours	Hours	Hours			
4154 N/2 H7P	465	274	24	16...30	77	8.5	■	90	9 500	-20...+75	57 500 / 25 000	97 500	①				
4154 N/2 H8P	540	315	24	16...30	80	8.9	■	120	11 000	-20...+75	55 000 / 22 500	92 500	②				
4158 N/2 H7P	465	274	48	36...72	77	8.5	■	90	9 500	-20...+75	57 500 / 25 000	97 500	①				
4158 N/2 H8P	540	315	48	36...72	80	8.9	■	120	11 000	-20...+75	55 000 / 22 500	92 500	②				

Subject to change

Speed control range from 500 rpm⁻¹ up to maximum nominal speed.
Standstill at 0 % PWM, maximum speed if control cable is interrupted.
To attain the specified service life, an external capacitor must be wired between the plus and minus strands. Please note the wiring suggestion on page 14.
* Power consumption at free air flow, these values can be significantly higher in the operating point.

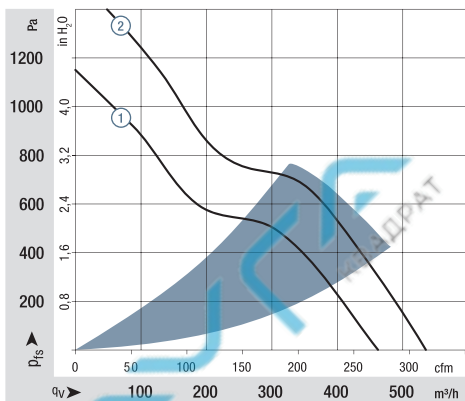

Air performance measured according to: ISO 5801.
Installation category A, without contact protection.
Noise: Total sound power level L_{WA} ISO 10302 measured on a hemisphere with a radius of 2 m.
Sound pressure level L_{pA} measured at 1 m distance from fan axis.
The values given are applicable only under the specified measuring conditions and may differ depending on the installation conditions.
In the event of deviation from the standard configuration, the parameters must be checked after installation!
For detailed information see <http://www.ebmpapst.com/general conditions>

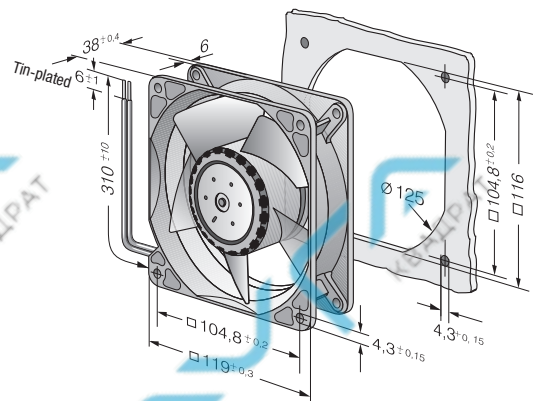

Max. 280 m³/h

DC diagonal fan

□ 119 x 38 mm



- **Material:** Housing: GRP¹⁾ (PBT)
Available in die-cast aluminum
Impeller: GRP¹⁾ (PA)
 - **Direction of air flow:** Exhaust over struts
 - **Direction of rotation:** Counterclockwise, looking towards rotor
 - **Connection:** Via single wires AWG 22, TR 64
 - **Highlights:** Housing with grounding lug for screw M4 x 8 (Torx)
 - **Weight:** 375 g (with metal housing: 455 g)
- **Possible special versions:** (See chapter DC fans - specials)
 - Speed signal
 - Go / NoGo alarm
 - Alarm with speed limit
 - External temperature sensor
 - Internal temperature sensor
 - PWM control input
 - Analog control input
 - Moisture protection
 - Salt spray protection
 - Degree of protection: IP 54 / IP 68

1) Fiberglass-reinforced plastic

Series DV 4100
VKC0119AUJBS

Nominal data

Type	Air flow		Nominal voltage	Voltage range	Sound pressure level	Sound power level	Sinter sleeve bearings Ball bearings	Power consumption*	Nominal speed	Temperature range	Service life L ₁₀ (40 °C) ebm-papst standard	Service life L ₁₀ (T _{max}) ebm-papst standard	Life expectancy L ₁₀ (IPC (40 °C) see page 15	Curve
	m ³ /h	cfm												
DV 4112 N	280	165	12	9...15	61	6.9	■	21.0	6 000	-20...+65	70 000 / 40 000	117 500	①	
DV 4114 N	280	165	24	16...30	61	6.9	■	20.5	6 000	-20...+65	70 000 / 40 000	117 500	①	
DV 4118 N	280	165	48	36...60	61	6.9	■	20.0	6 000	-20...+65	70 000 / 40 000	117 500	①	

Subject to change

* Power consumption at free air flow. These values can be significantly higher in the operating point.

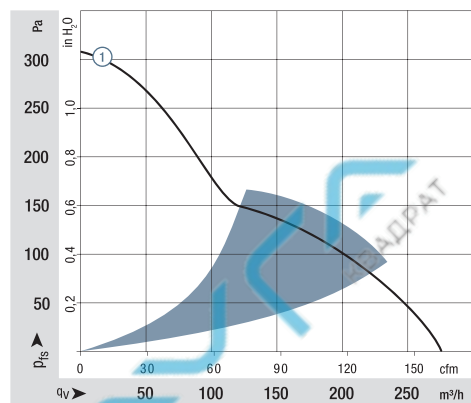

Air performance measured according to: ISO 5801.
Installation category A, without contact protection.
Noise: Total sound power level L_{WA} ISO 10302 measured on a hemisphere with a radius of 2 m.
Sound pressure level L_{pA} measured at 1 m distance from fan axis.

The values given are applicable only under the specified measuring conditions and may differ depending on the installation conditions.
In the event of deviation from the standard configuration, the parameters must be checked after installation!
For detailed information see <http://www.ebmpapst.com/general-conditions>

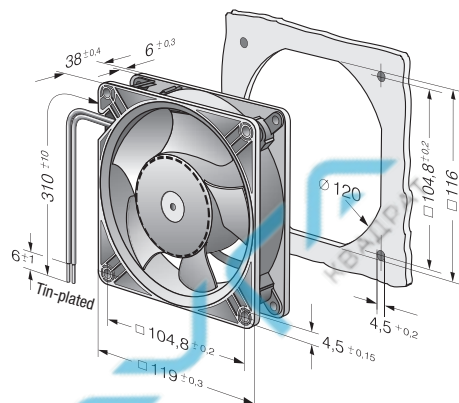

Max. 340 m³/h

DC axial fans

□ 127 x 38 mm



- **Material:** Housing: GRP¹⁾ (PBT)
Impeller: GRP¹⁾ (PA)
- **Direction of air flow:** Exhaust over struts
- **Direction of rotation:** Counterclockwise, looking towards rotor
- **Connection:** Via single wires AWG 22, TR 64
- **Weight:** 310 g

- **Possible special versions:** (See chapter DC fans - specials)
 - Speed signal
 - Go / NoGo alarm
 - Alarm with speed limit
 - External temperature sensor
 - Internal temperature sensor
 - PWM control input
 - Analog control input
 - Moisture protection
 - Salt spray protection
 - Degree of protection: IP 54 / IP 68

1) Fiberglass-reinforced plastic

Series 5200 N
WVC0127YUJBS

Nominal data

Type	Air flow		Nominal voltage	Voltage range	Sound pressure level	Sound power level	Sinter sleeve bearings Ball bearings	Power consumption**	Nominal speed	Temperature range	Service life L ₁₀ (40 °C) ebm-papst standard	Service life L ₁₀ (T _{max}) ebm-papst standard	Life expectancy L ₁₀ IPC (40 °C) see page 15	Curve
	m ³ /h	cfm												
5212 NM	187	110	12	7...14.5	43	5.3	■	4.1	2 750	-20...+75	62 500 / 27 500	105 000	①	
5212 NN	216	127	12	7...14	46	5.6	■	6.2	3 150	-20...+70	57 500 / 25 000	97 500	②	
5212 NH	252	148	12	7...14	51	6.0	■	9.8	3 650	-20...+70	45 000 / 22 500	75 000	③	
5212 NHH*	340	200	12	9...15	58	6.6	■	19.0	4 900	-20...+65	45 000 / 25 000	75 000	④	
5214 NM	187	110	24	12...28	43	5.3	■	4.6	2 750	-20...+75	62 500 / 27 500	105 000	①	
5214 NN	216	127	24	12...28	46	5.6	■	6.0	3 150	-20...+75	57 500 / 25 000	97 500	②	
5214 NH	252	148	24	12...28	51	6.0	■	9.8	3 650	-20...+70	45 000 / 22 500	75 000	③	
5214 NHH*	340	200	24	16...30	58	6.6	■	17.5	4 900	-20...+65	45 000 / 25 000	75 000	④	
5218 NM	187	110	48	36...56	43	5.3	■	4.5	2 750	-20...+75	62 500 / 27 500	105 000	①	
5218 NN	216	127	48	36...56	46	5.6	■	6.2	3 150	-20...+70	57 500 / 32 500	97 500	②	
5218 NH	252	148	48	36...56	51	6.0	■	9.6	3 650	-20...+55	45 000 / 32 500	75 000	③	
5218 NHH*	340	200	48	36...60	58	6.6	■	18.0	4 900	-20...+65	45 000 / 25 000	75 000	④	

Subject to change
* see drawing

** Power consumption at free air flow, these values can be significantly higher in the operating point.

*NHH models: fan housing with molded-in spacers.

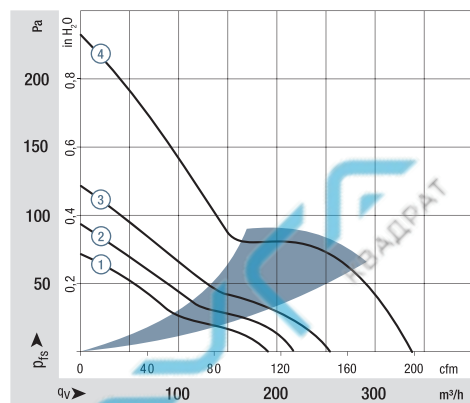
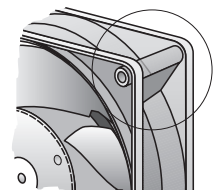

Air performance measured according to: ISO 5801.
Installation category A, without contact protection.
Noise: Total sound power level L_{WA} ISO 10302 measured on a hemisphere with a radius of 2 m.
Sound pressure level L_{pA} measured at 1 m distance from fan axis.
The values given are applicable only under the specified measuring conditions and may differ depending on the installation conditions.
In the event of deviation from the standard configuration, the parameters must be checked after installation!
For detailed information see <http://www.ebmpapst.com/general conditions>

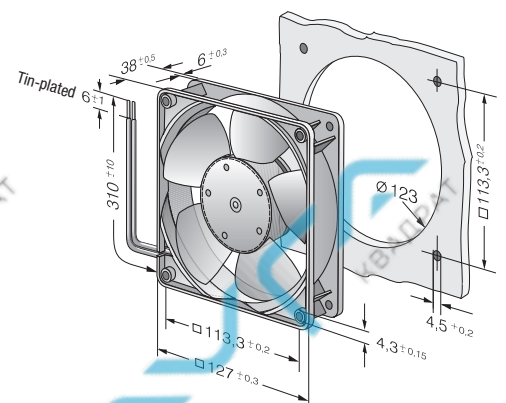

Max. 320 m³/h

DC diagonal fan

□ 127 x 38 mm



- **Material:** Housing: GRP¹⁾ (PBT)
Available in Die-cast aluminum
Metal flange
Impeller: GRP¹⁾ (PA)
 - **Direction of air flow:** Exhaust over struts
 - **Direction of rotation:** Counterclockwise, looking towards rotor
 - **Connection:** Via single wires AWG 22, TR 64
 - **Highlights:** Housing with grounding lug for screw M4 x 8 (Torx)
 - **Weight:** 415 g (with metal housing: 490 g)
- **Possible special versions:** (See chapter DC fans - specials)
 - Speed signal
 - Go / NoGo alarm
 - Alarm with speed limit
 - External temperature sensor
 - Internal temperature sensor
 - PWM control input
 - Analog control input
 - Moisture protection
 - Salt spray protection
 - Degree of protection: IP 54

1) Fiberglass-reinforced plastic

Series DV 5200
VKC0127AUJBS

Nominal data	Air flow		Nominal voltage	Voltage range	Sound pressure level	Sound power level	Sinter sleeve bearings Ball bearings	Power consumption*	Nominal speed	Temperature range	Service life L ₁₀ (40 °C) ebm-papst standard	Service life L ₁₀ (T _{max}) ebm-papst standard	Life expectancy L ₁₀ (IPC (40 °C) see page 15	Curve
	m ³ /h	cfm												
DV 5212 N	270	159	12	9...15	56	6.4	■	21.0	5 000	-20...+65	70 000 / 40 000	117 500	①	
DV 5214 N	270	159	24	16...30	56	6.4	■	20.4	5 000	-20...+65	70 000 / 40 000	117 500	①	
DV 5218 N	270	159	48	36...60	56	6.4	■	18.5	5 000	-20...+65	70 000 / 40 000	117 500	①	
Standard model comes with speed signal and PWM control input. Other versions by request.														
DV 5214/2 HP	320	188	24	16...30	62	7.2	■	38.5	6 000	-20...+65	62 500 / 35 000	105 000	②	

Subject to change

Speed control range from 1000 rpm⁻¹ up to maximum nominal speed.
Standstill at 0 % PWM, maximum speed if control cable is interrupted.

* Power consumption at free air flow. These values can be significantly higher in the operating point.

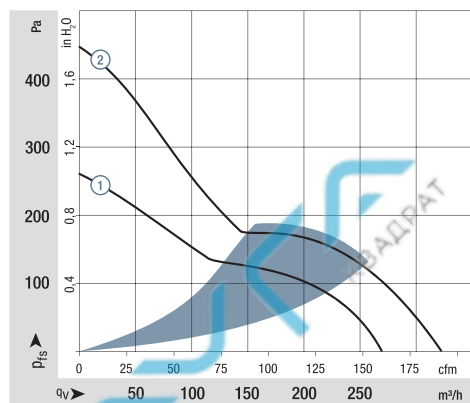

Air performance measured according to: ISO 5801.
Installation category A, without contact protection.
Noise: Total sound power level L_{WA} ISO 10302 measured on a hemisphere with a radius of 2 m.
Sound pressure level L_{pA} measured at 1 m distance from fan axis.
The values given are applicable only under the specified measuring conditions and may differ depending on the installation conditions.
In the event of deviation from the standard configuration, the parameters must be checked after installation!
For detailed information see <http://www.ebmpapst.com/general-conditions>

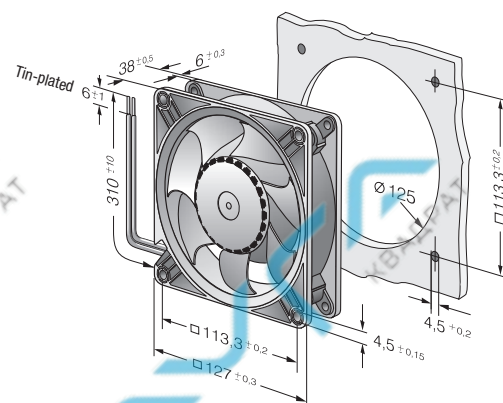

Max. 260 m³/h

DC axial fans

□ 135 x 38 mm



- **Material:** Housing: Die-cast aluminum
Impeller: painted sheet steel
 - **Direction of air flow:** Exhaust over struts
 - **Direction of rotation:** Counterclockwise, looking towards rotor
 - **Connection:** Via single wires AWG 22, TR 64
 - **Highlights:** Housing with grounding lug for screw M4 x 8 (Torx)
48 V design incl. screws.
 - **Weight:** 650 g
- **Possible special versions:** (See chapter DC fans - specials)
 - Speed signal
 - Go / NoGo alarm
 - Alarm with speed limit
 - External temperature sensor
 - Internal temperature sensor
 - PWM control input
 - Analog control input
 - Moisture protection
 - Salt spray protection
 - Degree of protection: IP 54

Series 5100 N
WVC0135YULBS

Nominal data

Type	Air flow		Nominal voltage		Voltage range		Sound pressure level		Sound power level		Sintec sleeve bearings Ball bearings		Power consumption*		Nominal speed		Temperature range		Service life L ₁₀ (40 °C) ebm-papst standard		Service life L ₁₀ (T _{max}) ebm-papst standard		Life expectancy L ₁₀ IPC (40 °C) see page 15		Curve	
	m ³ /h	cfm	VDC	VDC	dB(A)	Bel(A)	□ / ■	Watts	rpm ⁻¹	°C	Hours	Hours	Hours	Hours	Hours	Hours	Hours	Hours	Hours	Hours	Hours	Hours	Hours	Hours	Hours	Hours
5112 N	260	153	12	6...15	48	6.1	■	9.5	2 900	-25...+72	80 000 / 37 500	135 000	①													
5114 N	260	153	24	12...30	48	6.1	■	9.5	2 900	-25...+72	80 000 / 37 500	135 000	①													
5118 N	260	153	48	24...60	48	6.1	■	9.5	2 900	-25...+72	80 000 / 37 500	135 000	①													

Subject to change

* Power consumption at free air flow. These values can be significantly higher in the operating point.

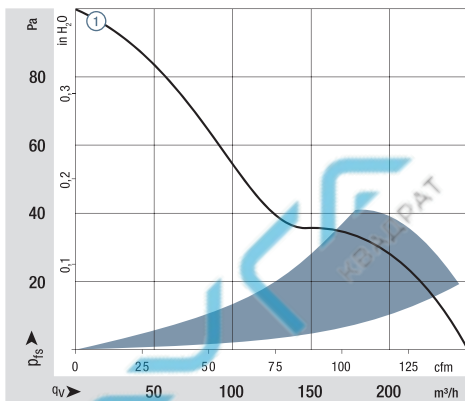

Air performance measured according to: ISO 5801.
Installation category A, without contact protection.
Noise: Total sound power level L_{WA} ISO 10302 measured on a hemisphere with a radius of 2 m.
Sound pressure level L_{pA} measured at 1 m distance from fan axis.
The values given are applicable only under the specified measuring conditions and may differ depending on the installation conditions.
In the event of deviation from the standard configuration, the parameters must be checked after installation!
For detailed information see <http://www.ebmpapst.com/general conditions>

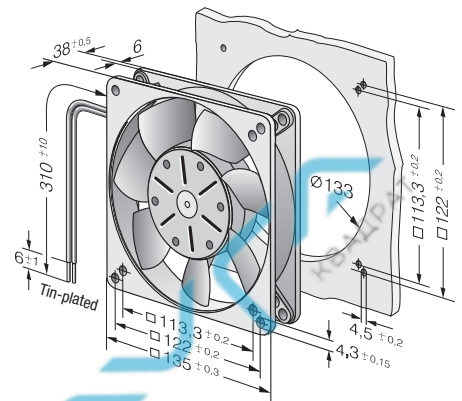

Max. 340 m³/h
S-Force

DC axial fans

□ 140 x 51 mm



- **Material:** Housing: Die-cast aluminum
Impeller: GRP¹⁾ (PA)
 - **Direction of air flow:** Intake over struts
 - **Direction of rotation:** Counterclockwise, looking towards rotor
 - **Connection:** Via single wires AWG 22, TR 64
 - **Highlights:** Housing with grounding lug for screw M4 x 8 (Torx)
 - **Weight:** 900 g
- **Possible special versions:** (See chapter DC fans - specials)
 - Speed signal
 - Go / NoGo alarm
 - Alarm with speed limit
 - External temperature sensor
 - Internal temperature sensor
 - PWM control input
 - Analog control input
 - Moisture protection
 - Salt spray protection
 - Degree of protection: IP 54

1) Fiberglass-reinforced plastic

Series 5300
VUC0140AULCS

Nominal data

Type	Air flow		Nominal voltage	Voltage range	Sound pressure level	Sound power level	Sinter sleeve bearings Ball bearings	Power consumption*	Nominal speed	Temperature range	Service life L ₁₀ (40 °C) ebm-papst standard	Service life L ₁₀ (T _{max}) ebm-papst standard	Life expectancy L ₁₀ (IPC (40 °C) see page 15	Curve
	m ³ /h	cfm												
5314/2 HP	340	200	24	16...28	64	7.2	■	28.4	5 000	-20...+65	77 500 / 40 000	130 000	130 000	①
5318/2 HP	340	200	48	36...72	64	7.2	■	27	5 000	-20...+65	77 500 / 40 000	130 000	130 000	①

Subject to change

Speed control range from 700 rpm⁻¹ up to maximum nominal speed.
Standstill at 0% PWM, maximum speed if control cable is interrupted.

* Power consumption at free air flow. These values can be significantly higher in the operating point.

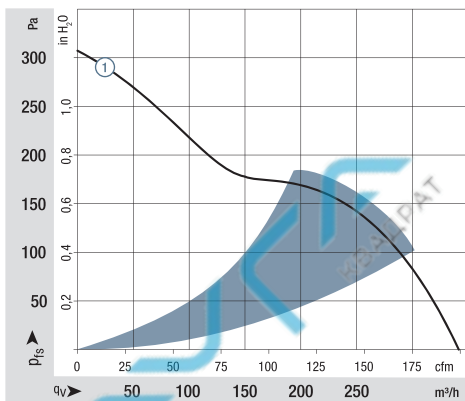

Air performance measured according to: ISO 5801.
Installation category A, without contact protection.
Noise: Total sound power level L_{WA} ISO 10302 measured on a hemisphere with a radius of 2 m.
Sound pressure level L_{pA} measured at 1 m distance from fan axis.
The values given are applicable only under the specified measuring conditions and may differ depending on the installation conditions.
In the event of deviation from the standard configuration, the parameters must be checked after installation!
For detailed information see <http://www.ebmpapst.com/general-conditions>

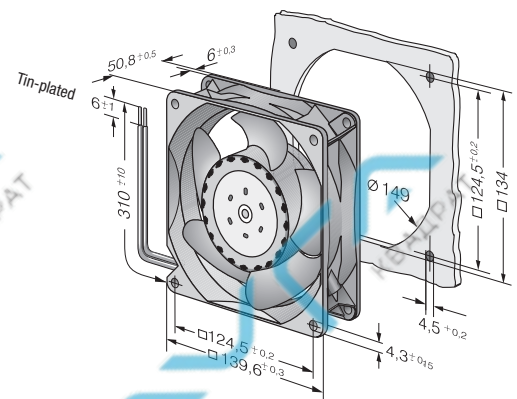

Max. 670 m³/h
S-Force

DC axial fans

□ 140 x 51 mm



- **Material:** Housing: Die-cast aluminum
Impeller: GRP¹⁾ (PA)
 - **Direction of air flow:** Intake over struts
 - **Direction of rotation:** Counterclockwise, looking towards rotor
 - **Connection:** Via single wires AWG 20 and AWG 22, TR 64
 - **Highlights:** 3-phase fan drive with very smooth operation
Housing with grounding lug for screw M4 x 8 (Torx)
 - **Weight:** 900 g
- **Possible special versions:** (See chapter DC fans - specials)
 - Speed signal
 - Go / NoGo alarm
 - Alarm with speed limit
 - External temperature sensor
 - Internal temperature sensor
 - PWM control input
 - Analog control input
 - Multi-option control input
 - Moisture protection
 - Salt spray protection
 - Degree of protection: IP 54

1) Fiberglass-reinforced plastic

Series 5300 TD
VUC0140AULDS

Nominal data

Type	Air flow		Nominal voltage	Voltage range	Sound pressure level	Sound power level	Sintec sleeve bearings Ball bearings	Power consumption*	Nominal speed	Temperature range	Service life L ₁₀ (40 °C) ebm-papst standard	Service life L ₁₀ (T _{max}) ebm-papst standard	Life expectancy L ₁₀ IPC (40 °C) see page 15	Curve
	m ³ /h	cfm												
5312/2 TDHP	410	241	12	8...16	70	7.7	■	43	6 000	-20...+70	70 000 / 35 000	117 500	①	
5314/2 TDHP	410	241	24	16...36	70	7.7	■	42	6 000	-20...+70	70 000 / 35 000	117 500	①	
5314/2 TDHHP	490	288	24	16...36	75	8.1	■	67	7 000	-20...+70	62 500 / 30 000	105 000	②	
5318/2 TDHP	410	241	48	36...72	70	7.7	■	42	6 000	-20...+70	70 000 / 35 000	117 500	①	
5318/2 TDHHP	490	288	48	36...72	75	8.1	■	66	7 000	-20...+70	62 500 / 30 000	105 000	②	
5318/2 TDH4P	670	394	48	36...72	79	8.8	■	149	9 200	-20...+65	57 500 / 32 500	97 500	③	

Subject to change

Speed control range from 1000 rpm⁻¹ up to maximum nominal speed.

Standstill at 0 % PWM, maximum speed if control cable is interrupted.

* Power consumption at free air flow. These values can be significantly higher in the operating point.

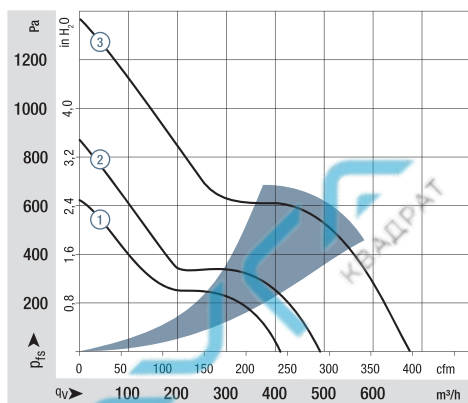

Air performance measured according to: ISO 5801.

Installation category A, without contact protection.

Noise: Total sound power level L_{WA} ISO 10302 measured on a hemisphere with a radius of 2 m.

Sound pressure level L_{PA} measured at 1 m distance from fan axis.

The values given are applicable only under the specified measuring conditions and may differ depending on the installation conditions.

In the event of deviation from the standard configuration, the parameters must be checked after installation!

For detailed information see

<http://www.ebmpapst.com/general-conditions>

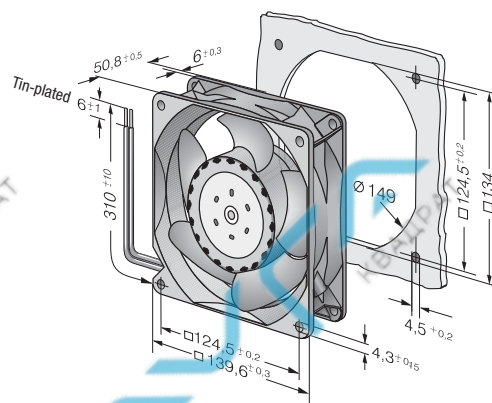

Max. 360 m³/h

DC axial fans

Ø 150 x 38 mm



- **Material:** Housing: Die-cast aluminum
Impeller: painted sheet steel
 - **Direction of air flow:** Exhaust over struts
 - **Direction of rotation:** Counterclockwise, looking towards rotor
 - **Connection:** Via single wires AWG 22, TR 64
 - **Highlights:** Housing with grounding lug for screw M4 x 8 (Torx)
 - **Weight:** 620 g
- **Possible special versions:** (See chapter DC fans - specials)
 - Speed signal
 - Go / NoGo alarm
 - Alarm with speed limit
 - External temperature sensor
 - Internal temperature sensor
 - PWM control input
 - Analog control input
 - Moisture protection
 - Salt spray protection
 - Degree of protection: IP 54 / IP 68

Series 7100 N
WWS0140XULBS

Nominal data

Type	Air flow		Nominal voltage	Voltage range	Sound pressure level	Sound power level	Sinter sleeve bearings Ball bearings	Power consumption*	Nominal speed	Temperature range	Service life L ₁₀ (40 °C) ebm-papst standard	Service life L ₁₀ (T _{max}) ebm-papst standard	Life expectancy L ₁₀ (IPC (40 °C) see page 15	Curve
	m ³ /h	cfm												
7112 N	308	181	12	6...15	53	6.2	■	12.0	2 850	-25...+72	80 000 / 37 500	135 000	①	
7114 N	308	181	24	12...30	53	6.2	■	12.0	2 850	-25...+72	80 000 / 37 500	135 000	①	
7114 NH	360	212	24	12...26.5	58	6.7	■	19.0	3 350	-25...+72	75 000 / 35 000	127 500	②	
7118 N	308	181	48	24...60	53	6.2	■	12.0	2 850	-25...+72	80 000 / 37 500	135 000	①	

Subject to change

* Power consumption at free air flow. These values can be significantly higher in the operating point.

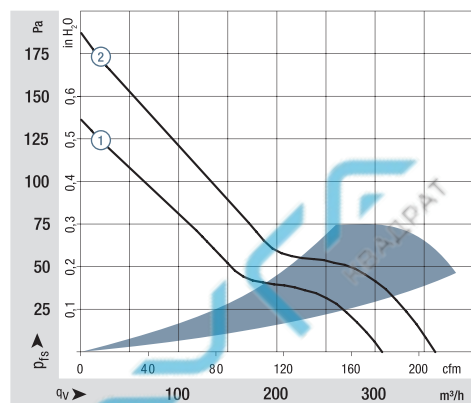

Air performance measured according to: ISO 5801.
Installation category A, without contact protection.
Noise: Total sound power level L_{WA} ISO 10302 measured on a hemisphere with a radius of 2 m.
Sound pressure level L_{pA} measured at 1 m distance from fan axis.
The values given are applicable only under the specified measuring conditions and may differ depending on the installation conditions.
In the event of deviation from the standard configuration, the parameters must be checked after installation!
For detailed information see <http://www.ebmpapst.com/general-conditions>

Wire fastened with cable tie.
Strand fastened using cable tie;
cable tie protrudes 1 mm.

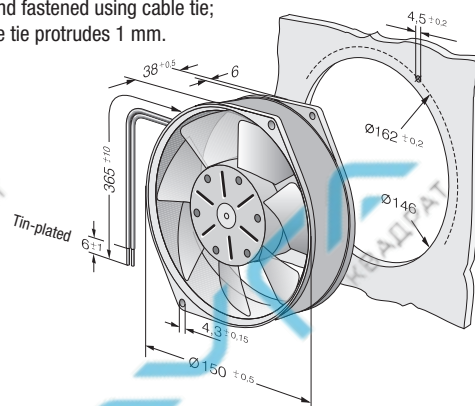

Max. 360 m³/h

DC axial fans

Ø 150 x 55 mm



- **Material:** Housing: Die-cast aluminum
Impeller: GRP¹⁾ (PA)
 - **Direction of air flow:** Exhaust over struts
 - **Direction of rotation:** Counterclockwise, looking towards rotor
 - **Connection:** Via single wires AWG 22, TR 64
 - **Highlights:** Housing with grounding lug for screw M4 x 8 (Torx)
 - **Weight:** 725 g
- **Possible special versions:** (See chapter DC fans - specials)
 - Speed signal
 - Go / NoGo alarm
 - Alarm with speed limit
 - External temperature sensor
 - Internal temperature sensor
 - PWM control input
 - Analog control input
 - Moisture protection
 - Salt spray protection
 - Degree of protection: IP 54 / IP 68

1) Fiberglass-reinforced plastic

Series 7200 N
WWS0143XULCS

Nominal data

Type	Air flow		Nominal voltage		Voltage range		Sound pressure level		Sound power level		Sintec sleeve bearings Ball bearings		Power consumption*		Nominal speed		Temperature range		Service life L ₁₀ (40 °C) ebm-papst standard		Service life L ₁₀ (T _{max}) ebm-papst standard		Life expectancy L ₁₀ IPC (40 °C) see page 15		Curve	
	m ³ /h	cfm	VDC	VDC	dB(A)	Bel(A)	□ / ■	Watts	rpm ⁻¹	°C	Hours	Hours	Hours	Hours	Hours	Hours	Hours	Hours	Hours	Hours	Hours	Hours	Hours	Hours	Hours	Hours
7212 N	360	212	12	6...15	53	6.2	■	12.0	3 050	-25...+72	80 000 / 37 500	135 000	①													
7214 N	360	212	24	12...30	53	6.2	■	12.0	3 050	-25...+72	80 000 / 37 500	135 000	①													
7218 N	360	212	48	24...60	53	6.2	■	12.0	3 050	-25...+72	80 000 / 37 500	135 000	①													

Subject to change

* Power consumption at free air flow. These values can be significantly higher in the operating point.

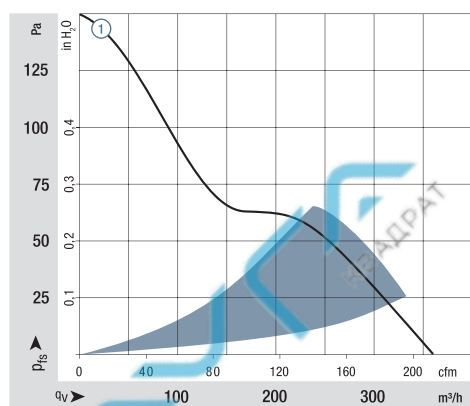

Air performance measured according to: ISO 5801.
Installation category A, without contact protection.
Noise: Total sound power level L_{WA} ISO 10302 measured on a hemisphere with a radius of 2 m.
Sound pressure level L_{PA} measured at 1 m distance from fan axis.
The values given are applicable only under the specified measuring conditions and may differ depending on the installation conditions.
In the event of deviation from the standard configuration, the parameters must be checked after installation!
For detailed information see <http://www.ebmpapst.com/general-conditions>

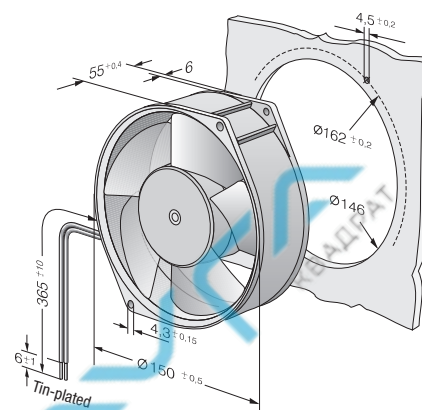

Max. 480 m³/h

DC axial fans

172 x 150 x 51 mm



- **Material:** Housing: Die-cast aluminum
Impeller: GRP¹⁾ (PA)
 - **Direction of air flow:** Exhaust over struts
 - **Direction of rotation:** Counterclockwise, looking towards rotor
 - **Connection:** on flat plugs 3 x 0.5 mm
 - **Highlights:** Housing with grounding lug for screw M4 x 8 (Torx)
 - **Weight:** 760 g
- **Possible special versions:** (See chapter DC fans - specials)
 - Speed signal
 - Go / NoGo alarm
 - Alarm with speed limit
 - External temperature sensor
 - Internal temperature sensor
 - PWM control input
 - Analog control input
 - Moisture protection
 - Salt spray protection
 - Degree of protection: IP 54

1) Fiberglass-reinforced plastic

Series 6400
WWS0143XULCS

Nominal data

Type	Air flow		Nominal voltage	Voltage range	Sound pressure level	Sound power level	Sintec sleeve bearings Ball bearings	Power consumption***	Nominal speed	Temperature range	Service life L ₁₀ (40 °C) ebm-papst standard	Service life L ₁₀ (T _{max}) ebm-papst standard	Life expectancy L ₁₀ IPC (40 °C) see page 15	Curve
	m ³ /h	cfm												
6412 M	350	206	12	8...15	52	6.0	■	12	2 850	-20...+72	80 000 / 37 500	135 000	①	
6424 M	350	206	24	12...32	52	6.0	■	12	2 850	-20...+72	80 000 / 37 500	135 000	①	
6424	410	241	24	12...28	57	6.4	■	17	3 400	-20...+72	75 000 / 35 000	127 500	②	
6424 H	480	283	24	12...28	63	7.1	■	26	4 000	-20...+55**	70 000 / 50 000	117 500	③	
6448	410	241	48	28...60	57	6.4	■	17	3 400	-20...+72	75 000 / 35 000	127 500	②	
6448 H*	480	283	48	28...60	63	7.1	■	26	4 000	-20...+55**	70 000 / 50 000	117 500	③	

Subject to change

* Strand 310 mm.

** 72 °C versions on request

*** Power consumption at free air flow, these values can be significantly higher in the operating point.

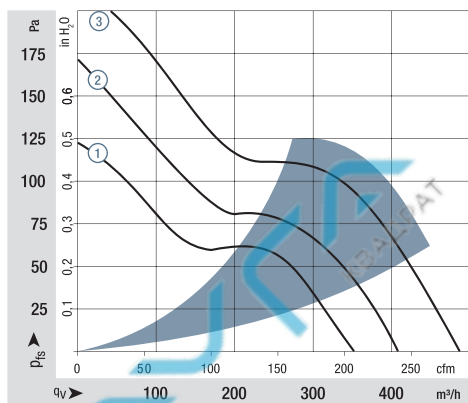

Air performance measured according to: ISO 5801.
Installation category A, without contact protection.
Noise: Total sound power level L_{WA} ISO 10302 measured on a hemisphere with a radius of 2 m.
Sound pressure level L_{pA} measured at 1 m distance from fan axis.
The values given are applicable only under the specified measuring conditions and may differ depending on the installation conditions.
In the event of deviation from the standard configuration, the parameters must be checked after installation!
For detailed information see <http://www.ebmpapst.com/general-conditions>

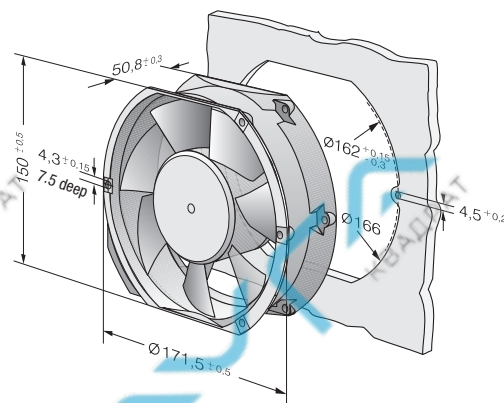

Max. 900 m³/h

DC axial fans

172 x 150 x 51 mm



- **Material:** Housing: Die-cast aluminum
Impeller: GRP¹⁾ (PA)
 - **Direction of air flow:** Exhaust over struts
 - **Direction of rotation:** Counterclockwise, looking towards rotor
 - **Connection:** Via single wires AWG 18, 20 or AWG 22, TR 64, speed signal and control input AWG 22
 - **Highlights:** Highly efficient and smoothly operating 3-phase fan drive
Housing with grounding lug for screw M4 x 8 (Torx)
 - **Weight:** 760 g
- **Possible special versions:** (See chapter DC fans - specials)
 - Speed signal
 - Go / NoGo alarm
 - Alarm with speed limit
 - External temperature sensor
 - Internal temperature sensor
 - PWM control input
 - Analog control input
 - Moisture protection
 - Salt spray protection
 - Degree of protection: IP 54
 - Reversible direction of rotation

1) Fiberglass-reinforced plastic

Series 6400 TD
WWS0143XULCS

Nominal data

Type	Air flow		Nominal voltage		Sound pressure level	Sound power level	Sintec sleeve bearings Ball bearings	Power consumption**	Nominal speed	Temperature range	Service life L ₁₀ (40 °C) ebm-papst standard	Service life L ₁₀ (T _{max}) ebm-papst standard	Life expectancy L ₁₀ IPC (40 °C) see page 15	Curve
	m ³ /h	cfm	VDC	VDC										
Min Max 6424 TD...	90	53	24	16...28	18	—	■	2	800	-20...+60	70 000 / 45 000	117 500		①
	600	353			65	7.4		50	5 100					②
Min Max 6448 TD...	90	53	48	40...55*	18	—	■	2	800	-20...+60	70 000 / 45 000	117 500		①
	600	353			65	7.4		50	5 100					②
Min Max 6448 TDH...	90	53	48	36...72	18	—	■	2	800	-20...+60	70 000 / 45 000	117 500		①
	900	530			78	8.6		163	7500					③

Subject to change

* Variants with an extended voltage range available on request.

Models 6424 TD..., 6448 TD... and 6448 TDH... are available in customer-specific, custom-developed variants only.

The figures indicated are technically feasible benchmark values. The fans can be specially adapted to your application with signal outputs and control inputs.

For details of the technical possibilities, refer to the chapters on the sensor signal, alarm signal and control inputs beginning on page 175.

** Power consumption at free air flow, these values can be significantly higher in the operating point.

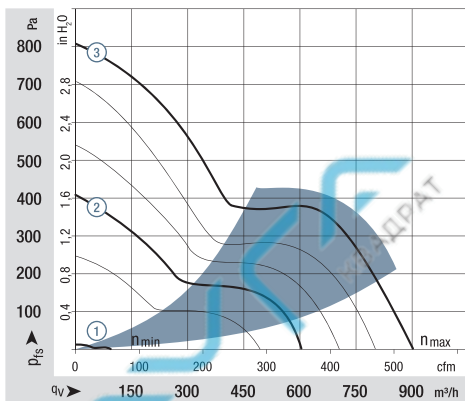

Air performance measured according to: ISO 5801.

Installation category A, without contact protection.

Noise: Total sound power level L_{WA} ISO 10302

measured on a hemisphere with a radius of 2 m.

Sound pressure level L_{pA} measured at 1 m distance

from fan axis.

The values given are applicable only under the specified measuring conditions and may differ depending on the installation conditions.

In the event of deviation from the standard configuration, the parameters must be checked after installation!

For detailed information see

<http://www.ebmpapst.com/general-conditions>

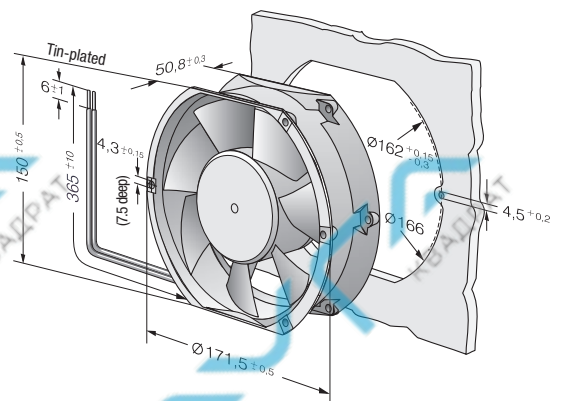

Max. 530 m³/h

DC diagonal fan

172 x 160 x 51 mm



- **Material:** Housing: Die-cast aluminum
Impeller: GRP¹⁾ (PA)
 - **Direction of air flow:** Exhaust over struts
 - **Direction of rotation:** Counterclockwise, looking towards rotor
 - **Connection:** Via single wires AWG 22, TR 64
 - **Highlights:** Housing with grounding lug for screw M4 x 8 (Torx)
 - **Weight:** 820 g
- **Possible special versions:** (See chapter DC fans - specials)
 - Speed signal
 - Go / NoGo alarm
 - Alarm with speed limit
 - External temperature sensor
 - Internal temperature sensor
 - PWM control input
 - Analog control input
 - Moisture protection
 - Salt spray protection
 - Degree of protection: IP 54

1) Fiberglass-reinforced plastic

Series DV 6400
VK0S154XULCS

Nominal data

Type	Air flow		Nominal voltage		Voltage range		Sound pressure level		Sound power level		Sintec sleeve bearings Ball bearings	Power consumption	Nominal speed	Temperature range	Service life L ₁₀ (40 °C) ebm-papst standard	Service life L ₁₀ (T _{max}) ebm-papst standard	Life expectancy L ₁₀ IPC (40 °C) see page 15	Curve
	m ³ /h	cfm	VDC	VDC	dB(A)	Bel(A)	Watts	rpm ⁻¹	°C	Hours								
DV 6424	530	312	24	16...28	65	7.3	■	40	4 300	-20...+75	90 000 / 35 000	152 500	①					
DV 6448/12	530	312	48	28...60	65	7.3	■	40	4 300	-20...+75	90 000 / 35 000	152 500	①					

Subject to change

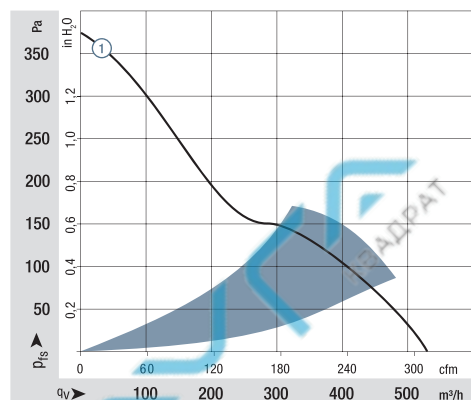

Air performance measured according to: ISO 5801.
Installation category A, without contact protection.
Noise: Total sound power level L_{WA} ISO 10302 measured on a hemisphere with a radius of 2 m.
Sound pressure level L_{pA} measured at 1 m distance from fan axis.
The values given are applicable only under the specified measuring conditions and may differ depending on the installation conditions.
In the event of deviation from the standard configuration, the parameters must be checked after installation!
For detailed information see <http://www.ebmpapst.com/general conditions>

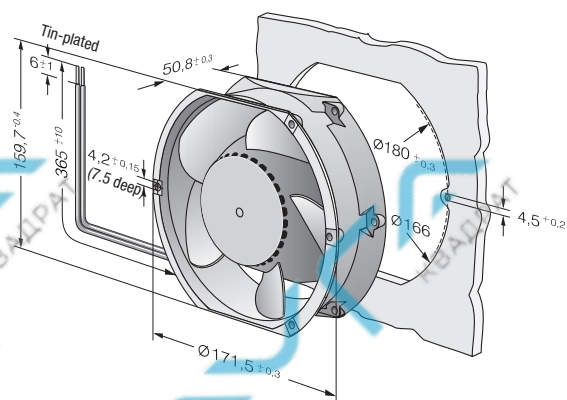

Max. 680 m³/h

DC diagonal fan

172 x 160 x 51 mm



- **Material:** Housing: Die-cast aluminum
Impeller: GRP¹⁾ (PA)
 - **Direction of air flow:** Exhaust over struts
 - **Direction of rotation:** Counterclockwise, looking towards rotor
 - **Connection:** Via single wires AWG 22, TR 64
 - **Highlights:** 3-phase fan drive with very smooth operation and high efficiency. Housing with grounding lug for screw M4 x 8 (Torx)
 - **Weight:** 820 g
- **Possible special versions:** (See chapter DC fans - specials)
 - Speed signal
 - Go / NoGo alarm
 - Alarm with speed limit
 - External temperature sensor
 - Internal temperature sensor
 - PWM control input
 - Analog control input
 - Moisture protection
 - Salt spray protection
 - Degree of protection: IP 54
 - Reversible direction of rotation

1) Fiberglass-reinforced plastic

Series DV 6400 TD
TURBOFAN
VKS0154XULCS

Nominal data

Type	Air flow		Nominal voltage		Voltage range		Sound pressure level		Sound power level		Sintec sleeve bearings Ball bearings	Power consumption*	Nominal speed	Temperature range	Service life L ₁₀ (40 °C) ebm-papst standard	Service life L ₁₀ (T _{max}) ebm-papst standard	Life expectancy L ₁₀ IPC (40 °C) see page 15	Curve
	m ³ /h	cfm	VDC	VDC	dB(A)	Bel(A)	□ / ■	Watts	rpm ⁻¹	°C	Hours	Hours	Hours					
Min Max DV 6424 TD...	100	59	24	16...28	29	—	■	2	800	-20...+60	65 000 / 40 000	110 000	①					
	680	400			71	7.9								91	5 500	②		
Min Max DV 6448 TD...	100	59	48	40...55	29	—	■	2	800	-20...+60	65 000 / 40 000	110 000	①					
	680	400			71	7.9								86	5 500	②		

Subject to change

Models DV 6424 TD... and DV 6448 TD... are available in customer-specific, custom-developed variants only.

The figures indicated are technically feasible benchmark values. The fans can be specially adapted to your application with signal outputs and control inputs.

For details of the technical possibilities, refer to the chapters on the sensor signal, alarm signal and control inputs beginning on page 175.

* Power consumption at free air flow. These values can be significantly higher in the operating point.

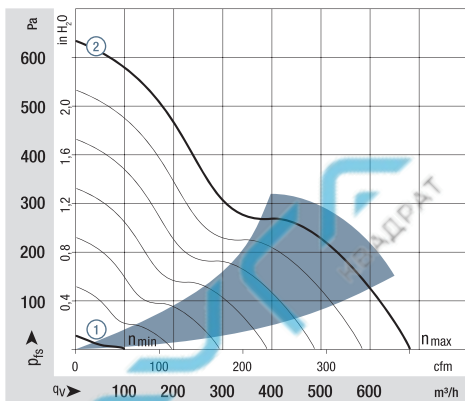

Air performance measured according to: ISO 5801.

Installation category A, without contact protection.

Noise: Total sound power level L_{WA} ISO 10302

measured on a hemisphere with a radius of 2 m.

Sound pressure level L_{pA} measured at 1 m distance from fan axis.

The values given are applicable only under the specified measuring conditions and may differ depending on the installation conditions.

In the event of deviation from the standard configuration, the parameters must be checked after installation!

For detailed information see

<http://www.ebmpapst.com/general-conditions>

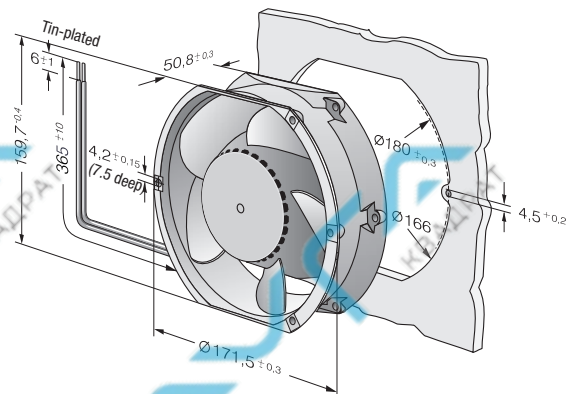

Max. 1030 m³/h
S-Panther



DC axial fans

172 x 160 x 51 mm

- **Material:** Housing: Die-cast aluminum
Impeller: GRP¹⁾ (PA)
 - **Direction of air flow:** Exhaust over struts
 - **Direction of rotation:** Counterclockwise, looking towards rotor
 - **Connection:** Via single wires AWG 18, 20 or AWG 22, TR 64, speed and alarm signals: AWG 22
 - **Highlights:** Highly efficient and smoothly operating 3-phase fan drive
Housing with grounding lug for screw M4 x 8 (Torx)
 - **Weight:** 875 g
- **Possible special versions:** (See chapter DC fans - specials)
 - Speed signal
 - Go / NoGo alarm
 - Alarm with speed limit
 - External temperature sensor
 - Internal temperature sensor
 - PWM control input (standard)
 - Analog control input
 - Multi-option control input
 - Moisture protection
 - Salt spray protection
 - Degree of protection: IP 54

1) Fiberglass-reinforced plastic

Series 6300 NTD
WWS0148PULDS

Nominal data

Type	Air flow		Nominal voltage	Voltage range	Sound pressure level	Sound power level	Sinter sleeve bearings Ball bearings	Power consumption*	Nominal speed	Temperature range	Service life L ₁₀ (40 °C) ebm-papst standard	Service life L ₁₀ (T _{max}) ebm-papst standard	Life expectancy L ₁₀ (IPC (40 °C) see page 15	Curve
	m ³ /h	cfm												
6318 N/2 TDH3P-303	1030	611	48	36...72	76	8.3	■	160	7 500	-20...+70	60 000 / 30 000		102 500	①

Subject to change

Speed control range from 1000 rpm⁻¹ up to maximum nominal speed. Standstill at 0 % PWM, maximum speed if control cable is interrupted.
* Power consumption at free air flow. These values can be significantly higher in the operating point.

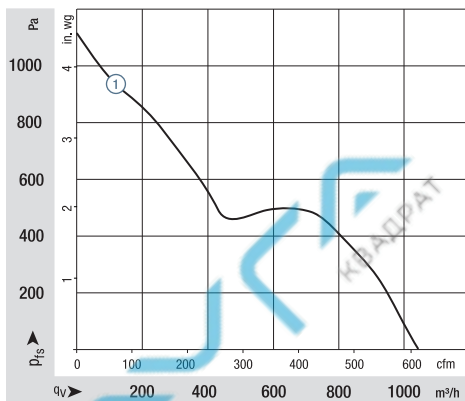

Air performance measured according to: ISO 5801.
Installation category A, without contact protection.
Noise: Total sound power level L_{WA} ISO 10302 measured on a hemisphere with a radius of 2 m.
Sound pressure level L_{pA} measured at 1 m distance from fan axis.
The values given are applicable only under the specified measuring conditions and may differ depending on the installation conditions.
In the event of deviation from the standard configuration, the parameters must be checked after installation!
For detailed information see <http://www.ebmpapst.com/general-conditions>

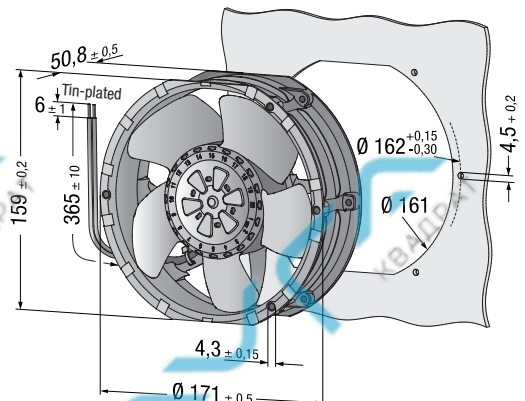

Max. 930 m³/h
S-Force

DC axial fans

172 x 160 x 51 mm



- **Material:** Housing: Die-cast aluminum
Impeller: GRP¹⁾ (PA)
 - **Direction of air flow:** Exhaust over struts
 - **Direction of rotation:** Counterclockwise, looking towards rotor
 - **Connection:** Via single wires AWG 18, 20 or AWG 22, TR 64, speed signal and control input AWG 22
 - **Highlights:** Highly efficient and smoothly operating 3-phase fan drive
Housing with grounding lug for screw M4 x 8 (Torx)
 - **Weight:** 910 g
- **Possible special versions:** (See chapter DC fans - specials)
 - Speed signal
 - Go / NoGo alarm
 - Alarm with speed limit
 - External temperature sensor
 - Internal temperature sensor
 - PWM control input (standard)
 - Analog control input
 - Multi-option control input
 - Moisture protection
 - Salt spray protection
 - Degree of protection: IP 54

1) Fiberglass-reinforced plastic

Series 6300 TD
WVS0148XULDS

Nominal data

Type	Air flow		Nominal voltage		Sound pressure level		Sintec sleeve bearings Ball bearings	Power consumption*	Nominal speed	Temperature range	Service life L ₁₀ (40 °C) ebm-papst standard	Service life L ₁₀ (T _{max}) ebm-papst standard	Life expectancy L ₁₀ IPC (40 °C) see page 15	Curve
	m ³ /h	cfm	VDC	VDC	dB(A)	Bel(A)								
6314/2 TDHHP-015	710	418	24	16...36	69	7.9	■	67	7 000	-20...+75	62 500 / 25 000	105 000	①	
6318/2 TDH4P-007	930	546	48	36...72	75	8.4	■	150	9 200	-20...+75	52 500 / 20 000	87 500	②	

Subject to change

Speed control range from 1000 rpm⁻¹ up to maximum nominal speed.
Standstill at 0 % PWM, maximum speed if control cable is interrupted.
* Power consumption at free air flow. These values can be significantly higher in the operating point.

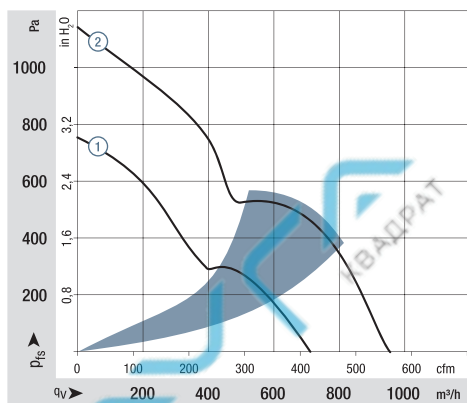

Air performance measured according to: ISO 5801.
Installation category A, without contact protection.
Noise: Total sound power level L_{WA} ISO 10302 measured on a hemisphere with a radius of 2 m.
Sound pressure level L_{pA} measured at 1 m distance from fan axis.
The values given are applicable only under the specified measuring conditions and may differ depending on the installation conditions.
In the event of deviation from the standard configuration, the parameters must be checked after installation!
For detailed information see <http://www.ebmpapst.com/general conditions>

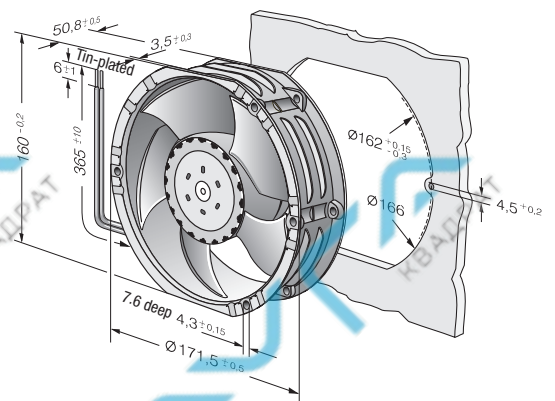

Max. 685 m³/h
S-Panther

DC axial fans

Ø 172 x 51 mm



- **Material:** Housing: Die-cast aluminum
Impeller: GRP¹⁾ (PA)
 - **Direction of air flow:** Exhaust over struts
 - **Direction of rotation:** Counterclockwise, looking towards rotor
 - **Connection:** (+) and GND AWG 20, UL 1007, TR 64; speed signal and alarm signal: AWG 22, UL 1007, TR 64
 - **Highlights:** Highly efficient and smoothly operating 3-phase fan drive
Housing with grounding lug for screw M4 x 8 (Torx)
 - **Weight:** 850 g
- **Possible special versions:** (See chapter DC fans - specials)
 - Speed signal
 - Go / NoGo alarm
 - Alarm with speed limit
 - External temperature sensor
 - Internal temperature sensor
 - PWM control input (standard)
 - Analog control input
 - Multi-option control input
 - Moisture protection
 - Salt spray protection
 - Degree of protection: IP 54 / IP 68

1) Fiberglass-reinforced plastic

Series 6300 N
WWS0148PULCS

Nominal data

Type	Air flow		Nominal voltage		Voltage range		Sound pressure level	Sound power level	Sintec sleeve bearings Ball bearings	Power consumption	Nominal speed	Temperature range	Service life L ₁₀ (40 °C) ebm-papst standard	Service life L ₁₀ (T _{max}) ebm-papst standard	Life expectancy L ₁₀ IPC (40 °C) see page 15	Curve
	m ³ /h	cfm	VDC	VDC	dB(A)	Bel(A)	Watts	rpm ⁻¹	°C	Hours	Hours					
6312 NM	340	200	12	8...16	-	5.7	8	2500	-20...+70	87 500 / 35 000	147 500	②				
6312 NH	470	277	12	8...16	-	6.5	24	3500	-20...+70	82 500 / 32 500	140 000	④				
6314 NM	340	200	24	16...32	-	5.7	8	2500	-20...+70	87 500 / 35 000	147 500	②				
6314 NN	420	247	24	16...32	-	6.3	13	3000	-20...+70	85 000 / 32 500	142 500	③				
6314 NH	470	277	24	16...32	-	6.5	20	3500	-20...+70	82 500 / 32 500	140 000	④				
6314 N/2 HHP	540	318	24	16...32	-	6.9	32	4000	-20...+70	80 000 / 40 000	135 000	⑤				
6318 NL	200	118	48	36...60	-	4.4	3	1500	-20...+70	90 000 / 35 000	152 500	①				
6318 NM	340	200	48	36...60	-	5.7	8	2500	-20...+70	87 500 / 35 000	147 500	②				
6318 N/2 HHP	540	318	48	36...60	-	6.9	32	4000	-20...+70	80 000 / 40 000	135 000	⑤				
6318 N/2 H3P	685	403	48	36...60	-	7.5	53	5000	-20...+70	77 500 / 40 000	130 000	⑥				

Subject to change

Speed control range from 1000 rpm⁻¹ up to maximum nominal speed. Standstill at 0 % PWM, maximum speed if control cable is interrupted.

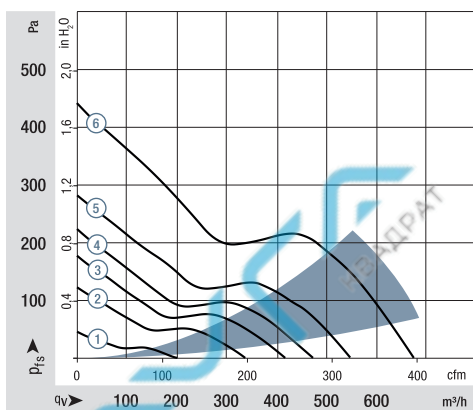

Air performance measured according to: ISO 5801.
Installation category A, without contact protection.
Noise: Total sound power level L_{WA} ISO 10302 measured on a hemisphere with a radius of 2 m.
Sound pressure level L_{pA} measured at 1 m distance from fan axis.
The values given are applicable only under the specified measuring conditions and may differ depending on the installation conditions.
In the event of deviation from the standard configuration, the parameters must be checked after installation!
For detailed information see <http://www.ebmpapst.com/general conditions>

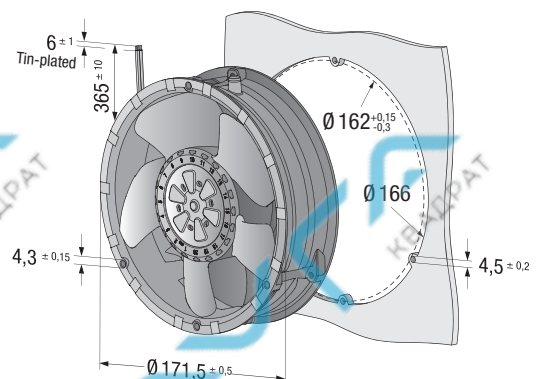

Max. 1210 m³/h
S-Panther

DC axial fans

Ø 172 x 51 mm



- **Material:** Housing: Die-cast aluminum
Impeller: GRP¹⁾ (PA)
- **Direction of air flow:** Exhaust over struts
- **Direction of rotation:** Counterclockwise, looking towards rotor
- **Connection:** AWG 18, 20, UL 1007, TR 64; speed signal and control input: AWG 22, UL 1007, TR 64
- **Highlights:** Highly efficient and smoothly operating 3-phase fan drive
Housing with grounding lug for screw M4 x 8 (Torx)
- **Weight:** 890 g
- **Possible special versions:** (See chapter DC fans - specials)
 - Speed signal
 - Go / NoGo alarm
 - Alarm with speed limit
 - External temperature sensor
 - Internal temperature sensor
 - PWM control input (standard)
 - Analog control input
 - Multi-option control input
 - Moisture protection
 - Salt spray protection
 - Degree of protection: IP 54

1) Fiberglass-reinforced plastic

Series 6300 NTD
WWS0148PULDS

Nominal data

Type	Air flow		Nominal voltage		Sound pressure level		Sintec sleeve bearings Ball bearings	Power consumption*	Nominal speed	Temperature range	Service life L ₁₀ (40 °C) ebm-papst standard	Service life L ₁₀ (T _{max}) ebm-papst standard	Life expectancy L ₁₀ IPC (40 °C) see page 15	Curve
	m ³ /h	cfm	VDC	VDC	dB(A)	Bel(A)								
6314 N/2 TDHHP	990	583	24	16...36	75	8.3	■	156	7200	-20...+70	62 500 / 32 500	105 000	②	
6318 N/2 TDHP	805	473	48	36...60	71	7.8	■	95	6000	-20...+70	75 000 / 37 500	127 500	①	
6318 N/2 TDH3P	1030	606	48	36...72	76	8.4	■	160	7500	-20...+70	60 000 / 30 000	102 500	③	
6318 N/2 TDH4P	1210	712	48	36...72	80	8.8	■	257	9000	-20...+65	45 000 / 25 000	75 000	④	

Subject to change

Speed control range from 1000 rpm⁻¹ up to maximum nominal speed.
Standstill at 0 % PWM, maximum speed if control cable is interrupted.

* Power consumption at free air flow. These values can be significantly higher in the operating point.

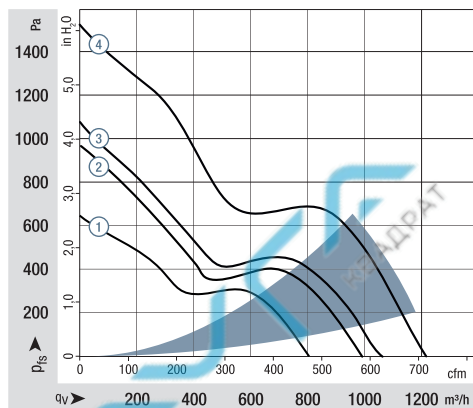

Air performance measured according to: ISO 5801.

Installation category A, without contact protection.

Noise: Total sound power level L_{WA} ISO 10302

measured on a hemisphere with a radius of 2 m.

Sound pressure level L_{pA} measured at 1 m distance from fan axis.

The values given are applicable only under the specified measuring conditions and may differ depending on the installation conditions.

In the event of deviation from the standard configuration, the parameters must be checked after installation!

For detailed information see

<http://www.ebmpapst.com/general-conditions>

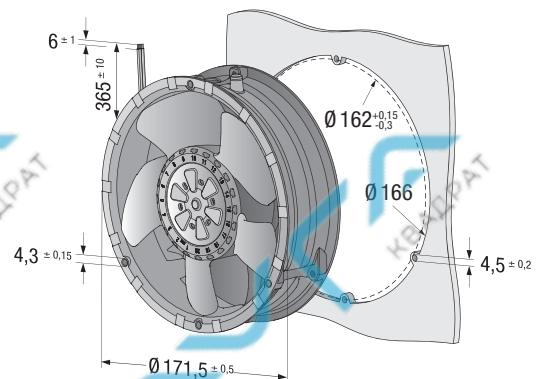

Max. 545 m³/h

S-Force

DC axial fans

Ø 172 x 51 mm



- **Material:** Housing: Die-cast aluminum
Impeller: GRP¹⁾ (PA)
 - **Direction of air flow:** Exhaust over struts
 - **Direction of rotation:** Counterclockwise, looking towards rotor
 - **Connection:** Via single wires AWG 22, TR 64
 - **Highlights:** Housing with grounding lug for screw M4 x 8 (Torx)
 - **Weight:** 825 g
- **Possible special versions:** (See chapter DC fans - specials)
 - Speed signal
 - Go / NoGo alarm
 - Alarm with speed limit
 - External temperature sensor
 - Internal temperature sensor
 - PWM control input (standard)
 - Analog control input
 - Moisture protection
 - Salt spray protection
 - Degree of protection: IP 54

1) Fiberglass-reinforced plastic

Series 6300
VWS0148XULCS

Nominal data

Type	Air flow		Nominal voltage	Voltage range		Sound pressure level		Sintec sleeve bearings Ball bearings	Power consumption*	Nominal speed	Temperature range	Service life L ₁₀ (40 °C) ebm-papst standard	Service life L ₁₀ (T _{max}) ebm-papst standard	Life expectancy L ₁₀ (IPC (40 °C) see page 15	Curve
	m ³ /h	cfm		VDC	VDC	dB(A)	Bel(A)								
6312/2 MP-204	360	211	12	8...16	49	5.8	■	15	3 500	-20...+65	82 500 / 47 500	140 000	①		
6314/2 MP	395	232	24	16...30	51	6.0	■	14	3 700	-20...+75	82 500 / 32 500	140 000	①		
6314/2 NP	470	276	24	16...30	56	6.5	■	23	4 400	-20...+70	80 000 / 40 000	135 000	②		
6314/2 HP	545	320	24	16...30	58	6.9	■	31	5 000	-20...+65	77 500 / 42 500	130 000	③		
6318/2 HP	545	320	48	36...72	58	6.9	■	32	5 000	-20...+65	77 500 / 42 500	130 000	③		

Subject to change

Speed control range from 700 rpm⁻¹ up to maximum nominal speed. Standstill at 0 % PWM, maximum speed if control cable is interrupted.

* Power consumption at free air flow. These values can be significantly higher in the operating point.

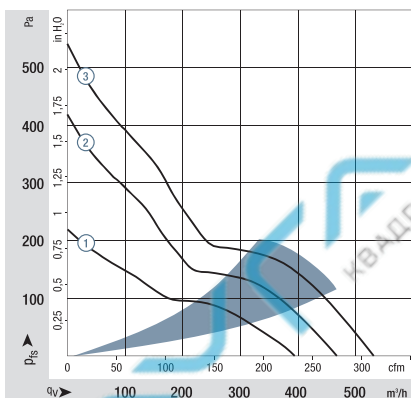

Air performance measured according to: ISO 5801.
Installation category A, without contact protection.
Noise: Total sound power level L_{WA} ISO 10302 measured on a hemisphere with a radius of 2 m.
Sound pressure level L_{pA} measured at 1 m distance from fan axis.
The values given are applicable only under the specified measuring conditions and may differ depending on the installation conditions.
In the event of deviation from the standard configuration, the parameters must be checked after installation!
For detailed information see <http://www.ebmpapst.com/general conditions>

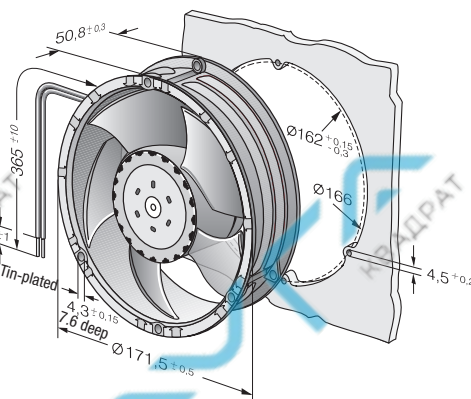

Max. 930 m³/h
S-Force

DC axial fans

Ø 172 x 51 mm



- **Material:** Housing: Die-cast aluminum
Impeller: GRP¹⁾ (PA)
 - **Direction of air flow:** Exhaust over struts
 - **Direction of rotation:** Counterclockwise, looking towards rotor
 - **Connection:** Via single wires AWG 18, 20 or AWG 22, TR 64, speed signal and control input AWG 22
 - **Highlights:** Highly efficient and smoothly operating 3-phase fan drive
Housing with grounding lug for screw M4 x 8 (Torx)
 - **Weight:** 910 g
- **Possible special versions:** (See chapter DC fans - specials)
 - Speed signal
 - Go / NoGo alarm
 - Alarm with speed limit
 - External temperature sensor
 - Internal temperature sensor
 - PWM control input (standard)
 - Analog control input
 - Multi-option control input
 - Moisture protection
 - Salt spray protection
 - Degree of protection: IP 54

1) Fiberglass-reinforced plastic

Series 6300 TD
WVS0148XULDS

Nominal data

Type	Air flow		Nominal voltage	Voltage range	Sound pressure level	Sound power level	Sinter sleeve bearings Ball bearings	Power consumption*	Nominal speed	Temperature range	Service life L ₁₀ (40 °C) ebm-papst standard	Service life L ₁₀ (T _{max}) ebm-papst standard	Life expectancy L ₁₀ (IPPC) (40 °C) see page 15	Curve
	m ³ /h	cfm												
6312/2 TDHP	600	353	12	8...16	60	7.3	■	40	5 500	-20...+70	75 000 / 37 500	127 500	②	
6314/2 TDHP-298	600	353	24	16...30	60	7.3	■	42	5 500	-20...+65	75 000 / 42 500	127 500	①	
6314/2 TDHP	600	353	24	16...36	60	7.3	■	40	5 500	-20...+75	75 000 / 30 000	127 500	②	
6314/2 TDHHP	710	418	24	16...36	69	7.9	■	67	7 000	-20...+75	62 500 / 25 000	105 000	③	
6314/2 TDH4P	930	545	24	16...36	75	8.4	■	150	9 200	-20...+75	52 500 / 20 000	87 500	④	
6318/2 TDHP-299	600	353	48	36...60	60	7.3	■	42	5 500	-20...+65	75 000 / 42 500	127 500	①	
6318/2 TDHP	600	353	48	36...72	60	7.3	■	40	5 500	-20...+75	75 000 / 30 000	127 500	②	
6318/2 TDHHP	710	418	48	36...72	69	7.9	■	67	7 000	-20...+75	62 500 / 25 000	105 000	③	
6318/2 TDH4P	930	545	48	36...72	75	8.4	■	150	9 200	-20...+75	52 500 / 20 000	87 500	⑤	

Subject to change

Speed control range from 1000 rpm⁻¹ up to maximum nominal speed.
Standstill at 0 % PWM, maximum speed if control cable is interrupted.

* Power consumption at free air flow. These values can be significantly higher in the operating point.

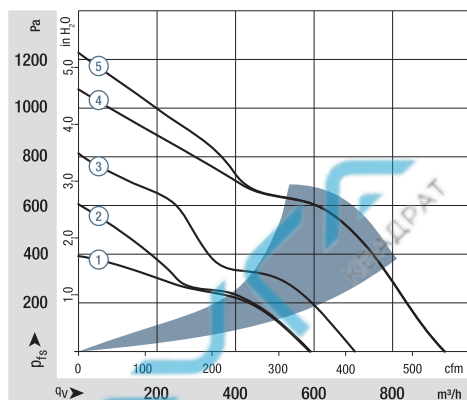

* Power consumption – in operation

Fan type	optimum operating range (W)
6318/2 TDHHP	115
6318/2 TDH4P	270

Air performance measured according to: ISO 5801.
Installation category A, without contact protection.

Noise: Total sound power level L_{WA} ISO 10302 measured on a hemisphere with a radius of 2 m.

Sound pressure level L_{pA} measured at 1 m distance from fan axis.

The values given are applicable only under the specified measuring conditions and may differ depending on the installation conditions.

In the event of deviation from the standard configuration, the parameters must be checked after installation!

For detailed information see

<http://www.ebmpapst.com/general-conditions>

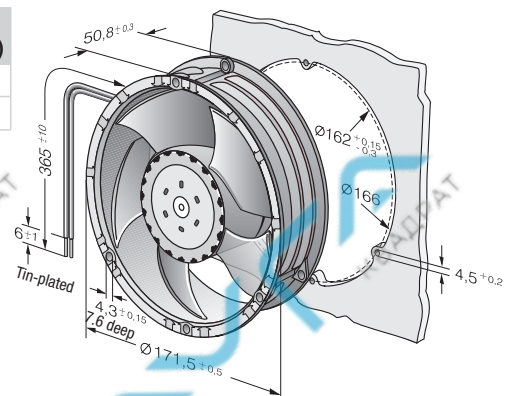

Max. 1100 m³/h

S-Force

DC diagonal fan

Ø 172 x 51 mm



- **Material:** Housing: Die-cast aluminum
Impeller: GRP¹⁾ (PA)
 - **Direction of air flow:** Exhaust over struts
 - **Direction of rotation:** Counterclockwise, looking towards rotor
 - **Connection:** (+) and GND: AWG 18, UL 1007, TR 64; speed and alarm signal: AWG 22, UL 1007, TR 64
 - **Highlights:** Highly efficient and smoothly operating 3-phase fan drive
Housing with grounding lug for screw M4 x 8 (Torx)
 - **Weight:** 1050 g
- **Possible special versions:** (See chapter DC fans - specials)
 - Speed signal
 - Go / NoGo alarm
 - Alarm with speed limit
 - External temperature sensor
 - Internal temperature sensor
 - PWM control input (standard)
 - Analog control input
 - Multi-option control input
 - Moisture protection
 - Salt spray protection
 - Degree of protection: IP 54

1) Fiberglass-reinforced plastic

Series DV 6300 TD
VKS0168XULDS

Nominal data

Type	Air flow		Nominal voltage	Voltage range	Sound pressure level	Sound power level	Sintec sleeve bearings Ball bearings	Power consumption	Nominal speed	Temperature range	Service life L ₁₀ (40 °C) ebm-papst standard	Service life L ₁₀ (T _{max}) ebm-papst standard	Life expectancy L ₁₀ (IP)PC (40 °C) see page 15	Curve
	m ³ /h	cfm												
DV 6314/2 TDHHP	730	429	24	16...36	72	8.0	■	118	4850	-20...+60	75 000 / 47 000	127 500	②	
DV 6318/2 TDHP*	630	371	48	36...72	68	7.6	■	75	4000	-20...+65	70 000 / 40 000	117 500	①	
DV 6318/2 TDHHP*	730	429	48	36...72	72	8.0	■	118	4850	-20...+65	60 000 / 32 500	102 500	②	
DV 6318/2 TDH4P	1050	617	48	36...72	77	8.7	■	300	6500	-20...+65	50 000 / 27 500	85 000	③	
DV 6318/2 TDH5P**	1100	647	48	36...72	79	8.9	■	360	6800	-20...+65	40 000 / 22 500	67 500	④	

Subject to change

* On request

** Rotor protrusion
a = 3 mm

Speed control range from 1000 rpm⁻¹ up to maximum nominal speed. Standstill at 0 % PWM, maximum speed if control cable is interrupted.

The fan has an acceleration of up to 30% that produces a smoother curve.

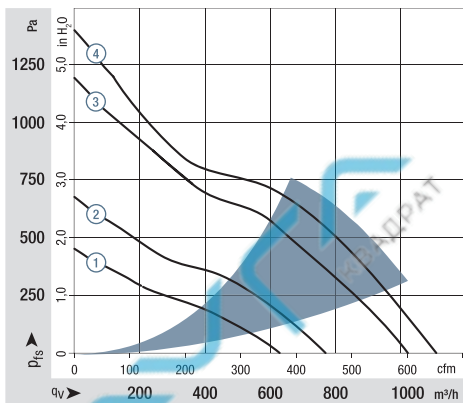

Air performance measured according to: ISO 5801.
Installation category A, without contact protection.
Noise: Total sound power level L_{WA} ISO 10302 measured on a hemisphere with a radius of 2 m.
Sound pressure level L_{pA} measured at 1 m distance from fan axis.
The values given are applicable only under the specified measuring conditions and may differ depending on the installation conditions.
In the event of deviation from the standard configuration, the parameters must be checked after installation!
For detailed information see <http://www.ebmpapst.com/general conditions>

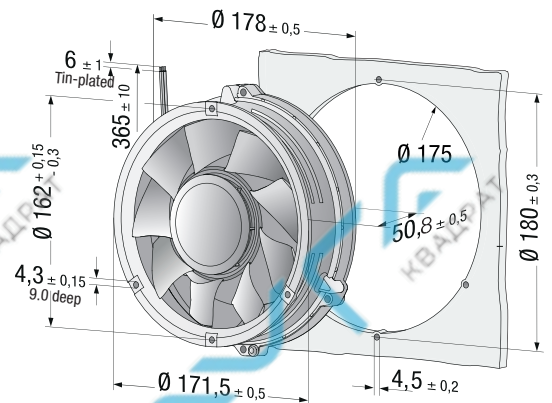

Max. 1220 m³/h

S-Force

DC axial fans

220 x 200 x 51 mm



- **Material:** Housing: Die-cast aluminum
Impeller: GRP¹⁾ (PA)
 - **Direction of air flow:** Exhaust over struts
 - **Direction of rotation:** Counterclockwise, looking towards rotor
 - **Connection:** Via single wires AWG 18, 20 or AWG 22, TR 64, speed signal and control input AWG 22
 - **Highlights:** Highly efficient and smoothly operating 3-phase fan drive
Housing with grounding lug for screw M4 x 8 (Torx)
 - **Weight:** 1000 g
- **Possible special versions:** (See chapter DC fans - specials)
 - Speed signal
 - Go / NoGo alarm
 - Alarm with speed limit
 - External temperature sensor
 - Internal temperature sensor
 - PWM control input
 - Analog control input
 - Multi-option control input
 - Moisture protection
 - Salt spray protection
 - Degree of protection: IP 54 / IP 68

1) Fiberglass-reinforced plastic

Series 2200 FTD
VWS0184FULDS
VWS0184FULCS

Nominal data

Type	Air flow		Nominal voltage	Voltage range	Sound pressure level	Sound power level	Sintec sleeve bearings Ball bearings	Power consumption*	Nominal speed	Temperature range	Service life L ₁₀ (40 °C) ebm-papst standard	Service life L ₁₀ (T _{max}) ebm-papst standard	Life expectancy L ₁₀ IPC (40 °C) see page 15	Curve
	m ³ /h	cfm												
2214 F/2 TDHO	790	465	24	16...30	62	7.1	■	35	4250	-20...+75	90 000 / 42 500	152 500	①	
2214 F/2 TDHHO	940	553	24	16...36	66	7.4	■	48	5000	-20...+70	85 000 / 42 500	142 500	②	
2218 F/2 TDHO	790	465	48	36...57	62	7.1	■	35	4250	-20...+75	90 000 / 42 500	152 500	①	
2218 F/2 TDHHO	940	553	48	36...72	66	7.4	■	48	5000	-20...+70	85 000 / 42 500	142 500	②	
2218 F/2 TDH4P	1220	718	48	36...72	72	8.2	■	103	6500	-20...+65	70 000 / 40 000	117 500	③	

Subject to change

Speed control range from 1000 rpm⁻¹ up to maximum nominal speed.

Standstill at 0 % PWM, Type O: standstill if control wire is interrupted; Type P: maximum speed if control wire is interrupted.

* Power consumption at free air flow. These values can be significantly higher in the operating point.

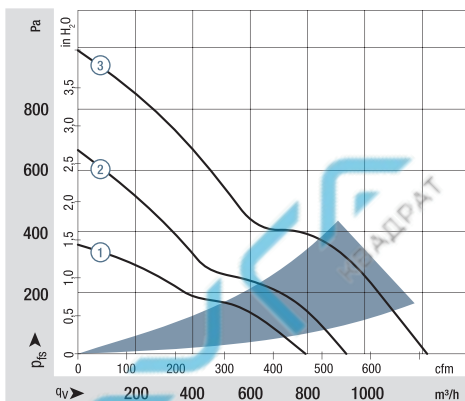

Air performance measured according to: ISO 5801.
Installation category A, without contact protection.
Noise: Total sound power level L_{WA} ISO 10302 measured on a hemisphere with a radius of 2 m.
Sound pressure level L_{pA} measured at 1 m distance from fan axis.

The values given are applicable only under the specified measuring conditions and may differ depending on the installation conditions.

In the event of deviation from the standard configuration, the parameters must be checked after installation!

For detailed information see

<http://www.ebmpapst.com/general-conditions>

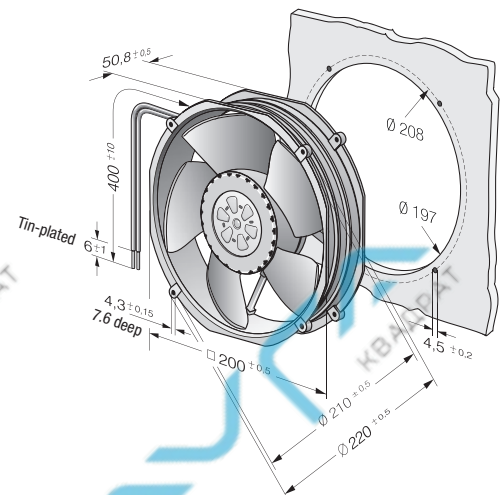

max. 1000 m³/h

DC axial fans

□ 225 x 80 mm



- **Material:** Fan housing: Die-cast aluminum
Impeller: GRP¹⁾
 - **Direction of air flow:** Exhaust over struts
 - **Direction of rotation:** Counterclockwise, looking towards rotor
 - **Connection:** Via terminal strip
 - **Highlights:** 3-phase fan drive with very smooth operation
Electrical commutation completely integrated
 - **Weight:** 2.1 kg
- **Possible special versions:** (See chapter DC fans - specials)
 - Speed signal
 - Go / NoGo alarm
 - Alarm with speed limit
 - External temperature sensor
 - Internal temperature sensor
 - PWM control input
 - Analog control input
 - Multi-option control input
 - Moisture protection
 - Degree of protection: IP 54

1) Fiberglass-reinforced plastic

Series 2200 TD
WVS0196XULCS

Nominal data

Type	Air flow		Nominal voltage	Voltage range	Sound pressure level	Sound power level	Sinter sleeve bearings Ball bearings	Power consumption	Nominal speed	Temperature range	Service life L ₁₀ (40 °C) ebm-papst standard	Service life L ₁₀ (T max) ebm-papst standard	Life expectancy L ₁₀ (IPC (40 °C) see page 15	Curve
	m ³ /h	cfm												
2214/2 TD0	1000	588	24	16...30	59	6.8	■	50	3 000	-20...+60	80 000 / 50 000	135 000	135 000	①
2218/2 TD0	1000	588	48	36...57	59	6.8	■	50	3 000	-20...+60	80 000 / 50 000	135 000	135 000	①

Subject to change

* Power consumption at free air flow. These values can be significantly higher in the operating point.

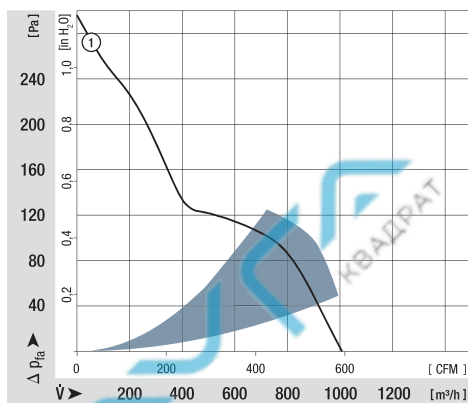

Air performance measured according to: ISO 5801.
Installation category A, without contact protection.
Noise: Total sound power level L_{WA} ISO 10302 measured on a hemisphere with a radius of 2 m.
Sound pressure level L_{PA} measured at 1 m distance from fan axis.
The values given are applicable only under the specified measuring conditions and may differ depending on the installation conditions.
In the event of deviation from the standard configuration, the parameters must be checked after installation!
For detailed information see <http://www.ebmpapst.com/general-conditions>

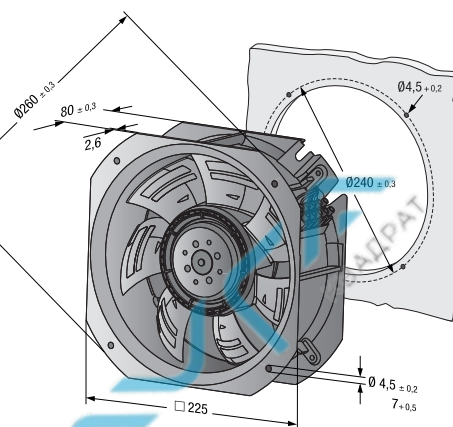

Max. 1245 m³/h

DC diagonal module

□ 225 x 80 mm



- **Material:** Housing and support bracket: Fiberglass-reinforced plastic (PA6)
Impeller: Fiberglass-reinforced plastic (PA6)
Rotor: Painted black
- **Number of blades:** 7
- **Direction of air flow:** "V"
- **Direction of rotation:** Clockwise, looking towards rotor
- **Degree of protection:** Ⓐ Ⓒ IP 44, Ⓑ Ⓓ IP 20, depending on installation and position
- **Insulation class:** "B"
- **Installation position:** Any
- **Condensation drainage holes:** Ⓐ Ⓒ none, Ⓑ Ⓓ seen on rotor
- **Mode of operation:** Continuous operation (S1)
- **Bearings:** Maintenance-free ball bearings

VJH0200XUNCS

Nominal data

Type	Motor	Curve	Nominal voltage VDC	Nominal voltage range VDC	Air flow m ³ /h	Nominal speed rpm ⁻¹	Power consumption W	Input current A	Sound power level dB(A)	Admissible amb. temp. °C	Weight kg	Technical features and connection diagram
K1G 200-AD65-04	M1G 074-BF	Ⓐ	24	16...28	1020	3 400	95	4.7	76	-25...+60	1.8	p. 277 / J5)
K1G 200-AD31-02	M1G 074-BF	Ⓑ	24	16...28	1045	3 500	110	5.4	77	-25...+70	1.7	p. 277 / J5)
K1G 200-AD49-04	M1G 074-BF	Ⓒ	48	36...57	1095	3 650	120	3.4	77	-25...+60	1.8	p. 277 / J5)
K1G 200-AD37-02	M1G 074-BF	Ⓓ	48	36...57	1245	4 140	183	5.6	81	-25...+70	1.7	p. 277 / J5)

Subject to change

Curves:

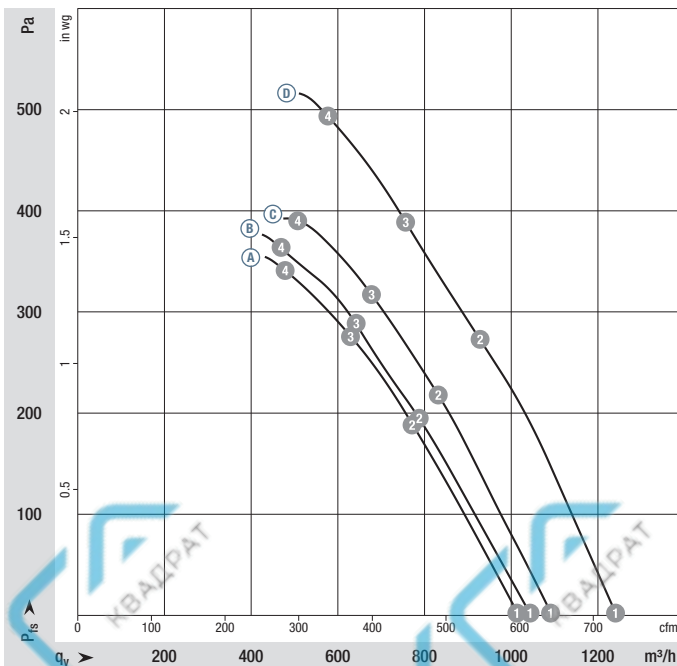

	n rpm ⁻¹	P _{ed} W	I A	L _{WA} dB(A)
Ⓐ 1	3400	95	4.70	76
Ⓐ 2	3410	116	5.61	74
Ⓐ 3	3410	119	5.75	74
Ⓐ 4	3410	117	5.62	76
Ⓑ 1	3500	110	5.40	77
Ⓑ 2	3510	127	6.24	75
Ⓑ 3	3510	129	6.31	75
Ⓑ 4	3510	125	6.15	76
Ⓒ 1	3650	120	3.40	77
Ⓒ 2	3645	141	3.90	75
Ⓒ 3	3640	145	3.99	76
Ⓒ 4	3645	141	3.88	80
Ⓓ 1	4140	183	5.60	81
Ⓓ 2	4080	212	6.46	79
Ⓓ 3	4060	213	6.52	79
Ⓓ 4	4105	211	6.43	80

Air performance measured according to: ISO 5801. Installation category A, without contact protection. Suction-side noise levels: L_{WA} according to ISO 13347, L_{pA} measured at 1 m distance from fan axis. The values given are applicable only under the specified measuring conditions and may differ depending on the installation conditions. In the event of deviation from the standard configuration, the parameters must be checked after installation! For detailed information see <http://www.ebmpapst.com/general-conditions>

- **Technical features:** See connection diagram p. 277
- **EMC:** Immunity to interference according to EN 61000-6-2 (industrial environment)
Interference emission according to EN 55022 (Class B)
- **Cable exit:** Lateral
- **Protection class:** I (with customer connection to grounding conductor)
- **Conformity with standard(s):** EN 60335-1
- **Approvals**
 - Ⓐ Ⓒ UL 1004-1, CSA C22.2 no. 77
 - Ⓑ Ⓓ EAC, UL 1004-1, CSA C22.2 no. 77

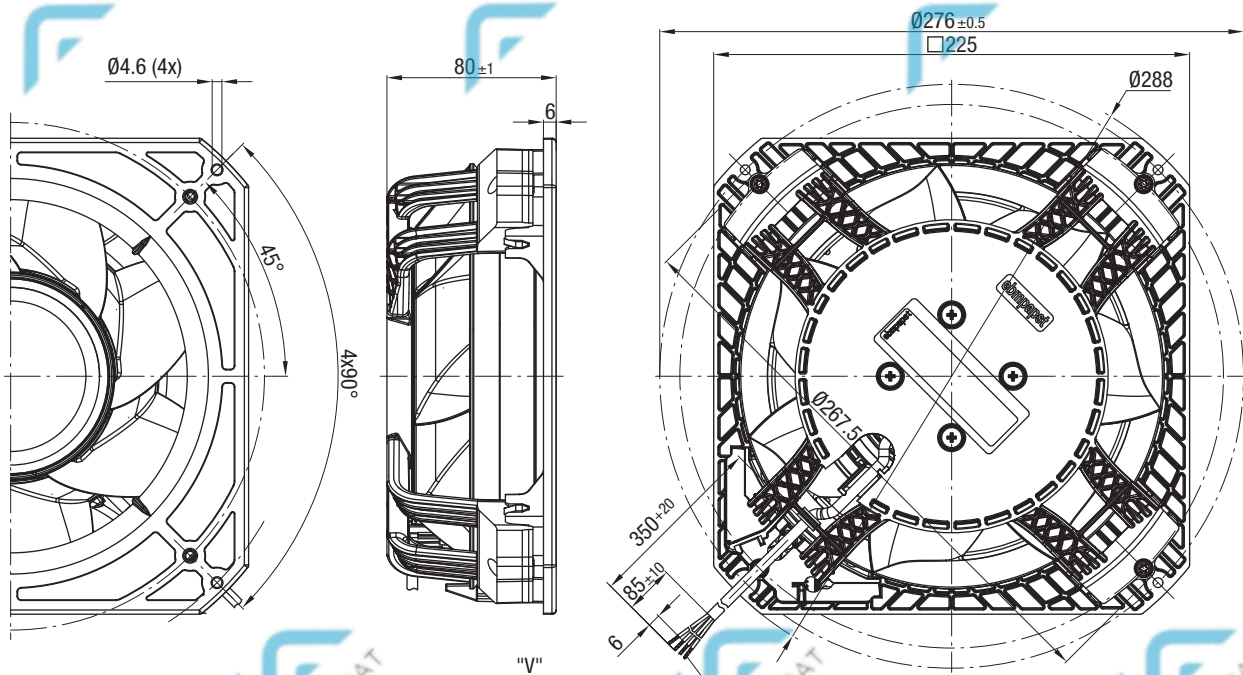

Cable assignment:
 Red = UN
 Yellow = 0-10 VDC
 White = tach output
 Blue = GND

AWG 20 cable,
 4x crimped splices

Max. 1650 m³/h

DC diagonal module

□ 225 x 89 mm



- **Material:** Housing and support bracket: Plastic (PA)
Impeller: Plastic (PA)
Rotor: Painted black
- **Number of blades:** 7
- **Direction of air flow:** "V"
- **Direction of rotation:** Clockwise, looking towards rotor
- **Degree of protection:** Ⓐ Ⓒ IP 44, Ⓑ Ⓓ IP 20, depending on installation and position
- **Insulation class:** "B"
- **Installation position:** Any
- **Condensation drainage holes:** Ⓐ Ⓒ none, Ⓑ Ⓓ seen on rotor
- **Mode of operation:** Continuous operation (S1)
- **Bearings:** Maintenance-free ball bearings

VJH0200XUNES

Nominal data

Type	Motor	Curve	Nominal voltage VDC	Nominal voltage range VDC	Air flow m ³ /h	Nominal speed rpm ⁻¹	Power consumption W	Input current A	Sound power level dB(A)	Admissible amb. temp. °C	Weight kg	Technical features and connection diagram
K3G 200-BD46-04	M3G 074-CF	Ⓐ	24	16...28	1240	4120	170	7.0	80	-25...+60	2.3	p. 277 / J5)
K3G 200-BD44-02	M3G 074-CF	Ⓑ	24	16...28	1445	4830	275	11.5	84	-25...+60	2.3	p. 277 / J5)
K3G 200-BD64-04	M3G 074-CF	Ⓒ	48	36...57	1475	4875	275	5.8	85	-25...+60	2.3	p. 277 / J5)
K3G 200-BDA8-02	M3G 074-CF	Ⓓ	48	36...57	1650	5470	400	8.4	88	-25...+60	2.3	p. 277 / J5)

Subject to change

Curves:

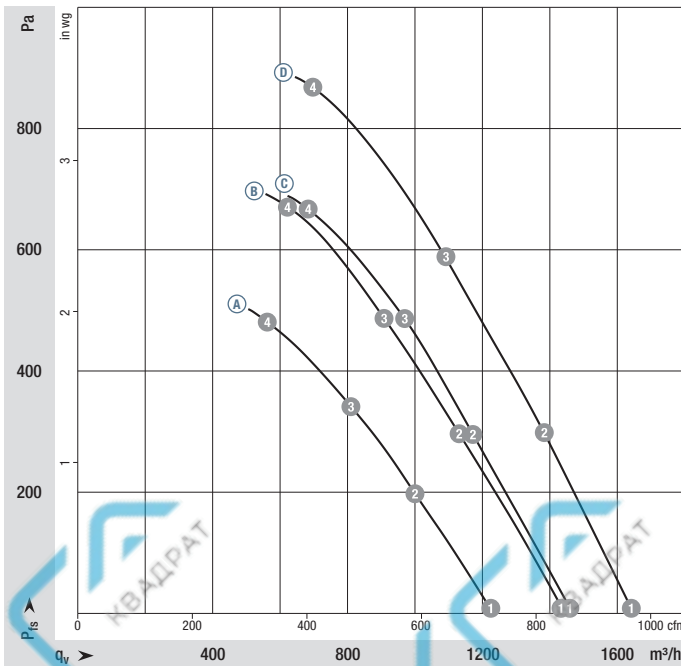

	n rpm ⁻¹	P _{ed} W	I A	L _{WA} dB(A)
Ⓐ 1	4120	170	7.00*	80
Ⓐ 2	4025	180	7.52*	77
Ⓐ 3	4005	187	7.80*	76
Ⓐ 4	4045	187	7.78*	78
Ⓑ 1	4830	275	11.50*	84
Ⓑ 2	4720	294	12.24*	81
Ⓑ 3	4685	299	12.48*	80
Ⓑ 4	4715	295	12.30*	83
Ⓒ 1	4875	275	5.80*	85
Ⓒ 2	4795	300	6.27*	81
Ⓒ 3	4755	307	6.41*	80
Ⓒ 4	4780	304	6.35*	82
Ⓓ 1	5470	400	8.40*	88
Ⓓ 2	5365	426	8.89*	85
Ⓓ 3	5310	438	9.17*	83
Ⓓ 4	5355	431	9.01*	87

* Current measured at nominal voltage.

Air performance measured according to: ISO 5801. Installation category A, without contact protection. Suction-side noise levels: LWA according to ISO 13347, LpA measured at 1 m distance from fan axis. The values given are applicable only under the specified measuring conditions and may differ depending on the installation conditions. In the event of deviation from the standard configuration, the parameters must be checked after installation! For detailed information see <http://www.ebmpapst.com/general-conditions>

- **Technical features:** See connection diagram p. 277
- **EMC (48 V):** Immunity to interference according to EN 61000-6-2 (industrial environment)
Interference emission according to EN 55022 (Class B, household environment)
- **Cable exit:** Lateral
- **Conformity with standard(s):** EN 60335-1
- **Approvals:** (24 V) EAC
(48 V) EAC, CCC

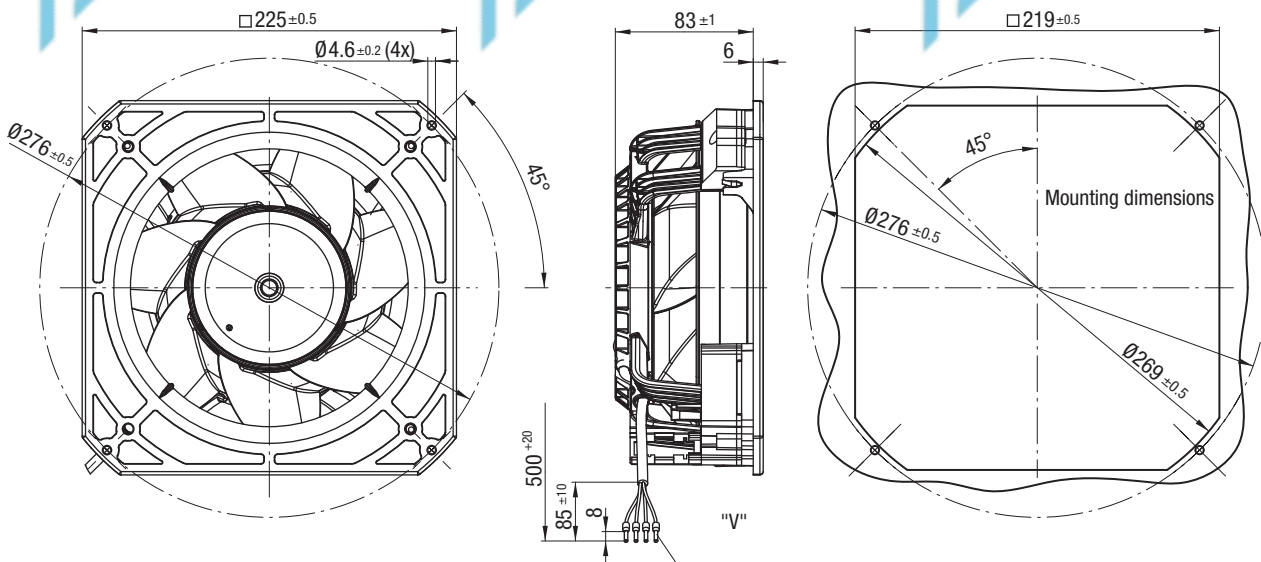

Cable assignment:
 Red = UN
 Yellow = 0-10 VDC
 White = tach output
 Blue = GND

PVC AWG 16 cable
 4x crimped ferrules

Max. 2070 m³/h

DC axial fans

Ø 250 mm



- **Material:** Fan housing: Die-cast aluminum
Blades: Plastic (PP)
Rotor: Thick-film passivated
- **Number of blades:** 7
- **Direction of air flow:** "V"
- **Direction of rotation:** Counterclockwise, looking towards rotor
- **Insulation class:** "B"
- **Installation position:** Any
- **Condensation drainage holes:** On rotor side
- **Mode of operation:** Continuous operation (S1)
- **Bearings:** Maintenance-free ball bearings

WWT250XUNCS

Nominal data

Type	Motor	Curve	Nominal voltage VDC	Nominal voltage range VDC	Air flow m ³ /h	Nominal speed rpm ⁻¹	Power consumption W	Input current A	Max. back-pressure Pa	Admissible amb. temp. °C	Technical features and connection diagram
W1G250-HJ87 -02	M1G074-BF	Ⓐ	24	16-28	2070	3090	120	7.00	150	-25...+60	p. 273 / E)
W1G250-HJ20 -02	M1G074-BF	Ⓑ	48	36-57	2070	3100	130	3.80	140	-25...+60	p. 273 / E)

Subject to change

Curves:

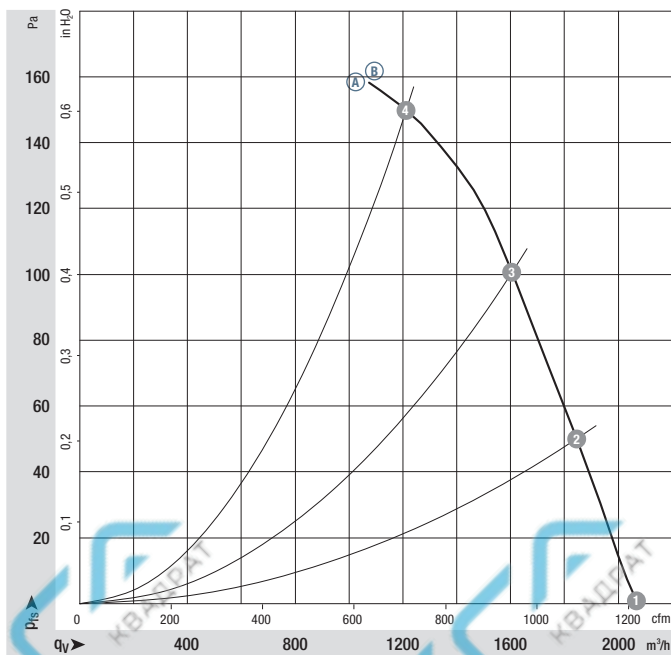

	n rpm ⁻¹	P _{ed} W	I A	L _{WA} dB(A)
Ⓐ ①	3090	120	6.80	74
Ⓐ ②	2950	124	7.10	73
Ⓐ ③	2820	127	7.43	73
Ⓐ ④	2730	130	7.80	78
Ⓑ ①	3100	130	3.80	74
Ⓑ ②	2945	133	4.10	73
Ⓑ ③	2810	135	4.20	73
Ⓑ ④	2720	136	4.20	78

Air performance measured according to: ISO 5801. Installation category A, without contact protection. Suction-side noise levels: L_{WA} according to ISO 13347, L_{pA} measured at 1 m distance from fan axis. The values given are applicable only under the specified measuring conditions and may differ depending on the installation conditions. In the event of deviation from the standard configuration, the parameters must be checked after installation! For detailed information see <http://www.ebmpapst.com/general-conditions>

- **Technical features:** See connection diagram p. 273
- **EMC:** Interference emission acc. to EN 55022 (Class B)
Immunity to interference acc. to EN 61000-6-2 (industrial environment)
- **Electrical hookup:** Via terminal strip
- **Protection class:** I
- **Conformity with standard(s):** EN 60950-1

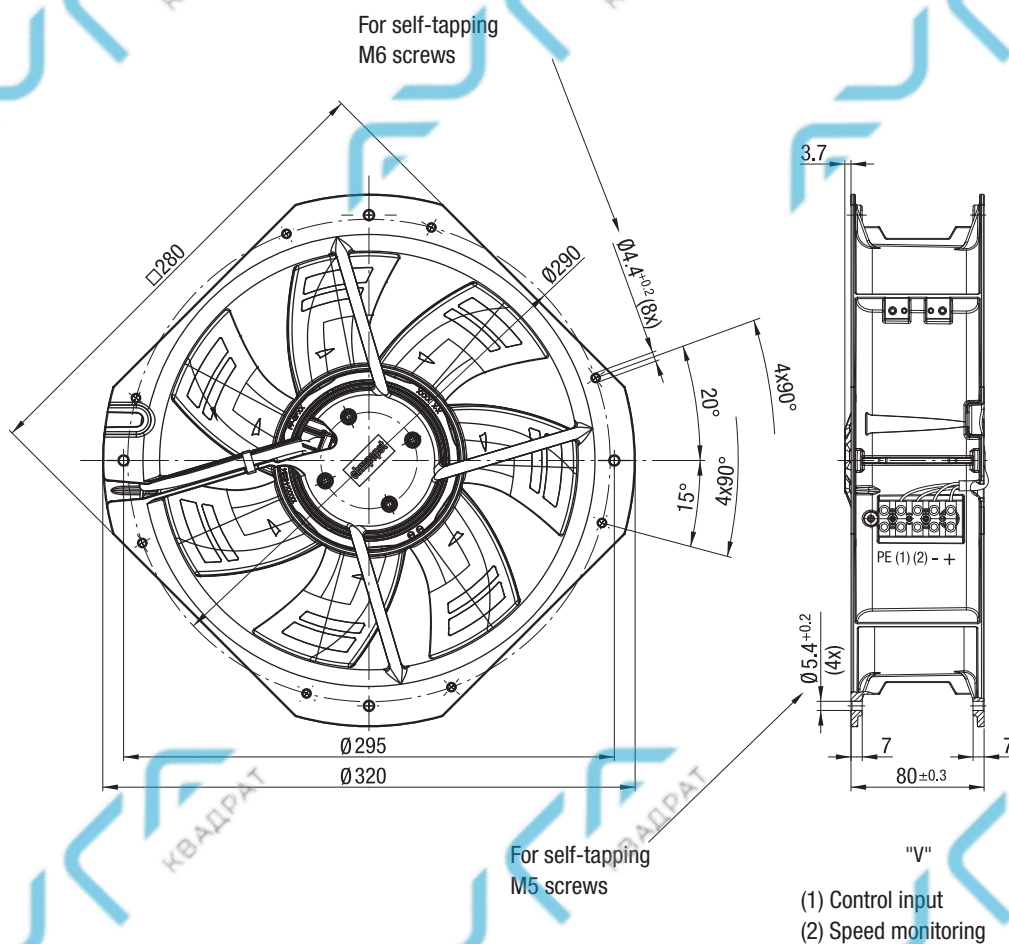

Max. 2345 m³/h

DC axial fans – HyBlade®

Ø 300 mm



- **Material:** Finger guard: Steel, phosphated and coated in black plastic
Fan housing: Sheet steel, pre-galvanized and coated in black plastic
Blades: Plastic (PP)
Rotor: Painted black
- **Number of blades:** 5
- **Direction of air flow:** "V"
- **Direction of rotation:** Counterclockwise, looking towards rotor
- **Degree of protection:** IP 42
- **Insulation class:** "B"
- **Installation position:** Any
- **Condensation drainage holes:** None
- **Mode of operation:** Continuous operation (S1)
- **Bearings:** Maintenance-free ball bearings

VWY0300XUNES
VWR0300XUNES
VMA0300XUNES

Nominal data

Type	Motor	Curve	Nominal voltage VDC	Nominal voltage range VDC	Air flow m ³ /h	Nominal speed rpm ⁻¹	Power consumption W	Input current A	Max. back-pressure Pa	Admissible amb. temp. °C	Technical features and connection diagram
*1G 300	M1G074-CF	Ⓐ	24	16-28	2320	1830	80	3.80	100	-25..+60	p. 277 / J5)
*1G 300	M1G074-CF	Ⓑ	48	36-57	2345	1830	80	1.90	100	-25..+60	p. 277 / J5)

Subject to change

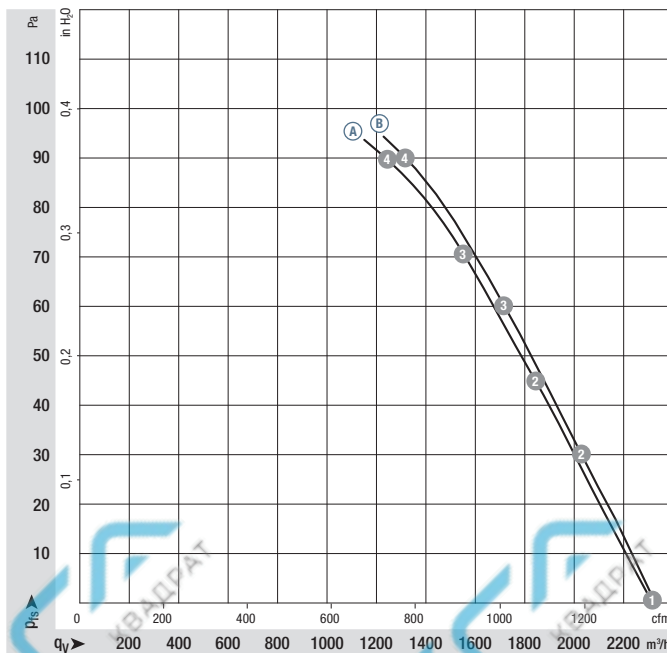

Curves:



	n rpm ⁻¹	P _{ed} W	I A	L _{wA} dB(A)
Ⓐ ①	1810	80	3.80	67
Ⓐ ②	1730	86	4.03	67
Ⓐ ③	1690	87	4.10	66
Ⓐ ④	1635	89	4.21	70
Ⓑ ①	1870	87	2.00	68
Ⓑ ②	1805	90	2.10	67
Ⓑ ③	1765	91	2.13	67
Ⓑ ④	1695	92	2.19	69

Air performance measured according to: ISO 5801, installation category A, in ebmpapst full nozzle without contact protection. Suction-side noise levels: L_{wA} according to ISO 13347, L_{wA} measured at 1 m distance from fan axis. The values given are applicable only under the specified measuring conditions and may differ depending on the installation conditions. In the event of deviation from the standard configuration, the parameters must be checked after installation! For detailed information see <http://www.ebmpapst.com/general-conditions>

- **Technical features:** See connection diagram p. 277
- **EMC:** Interference emission acc. to EN 55022 (Class B)
Immunity to interference acc. to EN 61000-6-2 (industrial environment)
- **Cable exit:** Lateral
- **Conformity with standard(s):** EN 60950-1, UL 1004-1, CSA C22.2 no. 100
- **Approvals:** GOST, UL

Airflow direction		Weight without attachments		Weight with full round nozzle		Weight with finger guard for short nozzle
	without attachments	kg	With full round nozzle	kg	With finger guard for short nozzle	kg
"V"	A1G 300-AC19 -54	1.8	W1G300-DC19 -54	3.8	S1G 300-AC19 -54	2.8
"V"	A1G 300-AC33 -54	1.8	W1G300-DC33 -54	3.8	S1G 300-AC33 -54	3.1

